

# SOUTH YORKSHIRE RESIDENTIAL DESIGN GUIDE

2011



INTEGRATED



VITAL, ACTIVE AND WELL MANAGED



EQUITABLE, COHESIVE, INCLUSIVE AND SAFE



LOCAL, DISTINCTIVE AND ATTRACTIVE



EFFICIENT, FLEXIBLE AND ADAPTABLE



## SOUTH YORKSHIRE RESIDENTIAL DESIGN GUIDE

### January 2011

Prepared by studio | REAL for  
Transform South Yorkshire  
Barnsley Metropolitan Borough Council  
Doncaster Metropolitan Borough Council  
Rotherham Metropolitan Borough Council  
Sheffield City Council

Preparation of this document has involved a number of workshops with a range of stakeholders and collaborative working with Transform South Yorkshire and the four local authorities: Barnsley Metropolitan Borough Council, Doncaster Metropolitan Borough Council, Rotherham Metropolitan Borough Council and Sheffield City Council.

All Ordnance Survey mapping reproduced in this document is © Crown Copyright, all rights reserved, and reproduced under the Local Authority Licence 100018816, 2010.

All other imagery in this document is the copyright of studio | REAL unless otherwise stated.

### Transform South Yorkshire

Peter O'Brien  
Planning and Design Advisor  
25 Carbrook Hall Road  
Sheffield S9 2EJ

T 0114 2735401  
F 0114 2734587  
E [peter.o'brien@sheffield.gov.uk](mailto:peter.o'brien@sheffield.gov.uk)



# Contents

1	INTRODUCTION	1
2	WORKING WITH THE GUIDE	7
3	THE DESIGN GUIDELINES	35
4	TECHNICAL REQUIREMENTS	128
Ap	APPENDICES	197
I	INDEX	233

---

# Detailed contents

<b>1</b>	<b>INTRODUCTION</b>	<b>1</b>
1.1	Who should use the Guide?	1
1.2	What scale of development is covered by the Guide?	1
1.3	Status of the Guide	2
1.4	Where to find what you need	2
1.5	The purpose of the Guide	4
1.6	The policy context and Building for Life	5
<b>2</b>	<b>WORKING WITH THE GUIDE</b>	<b>7</b>
2.1	Criteria for design quality: Building for Life	7
2.2	What are the main stages in the design and assessment process?	7
2.3	How is each stage dealt with?	7
2.4	How much information is required?	8
2.5	Which criteria and guidelines apply to smaller schemes?	8
2.6	How does the Building for Life assessment work?	8
2.7	Who does the Building for Life assessment work?	9
2.8	What are the criteria and how are they scored?	9
2.9	Design and Access Statements	10
2.10	Design Stage Checklists	11
2.11	Building for Life Assessment Sheets	16
<b>3</b>	<b>THE DESIGN GUIDELINES</b>	<b>35</b>
<b>3.1</b>	<b>Assessment, inclusion and appraisal</b>	<b>37</b>
<b>A1</b>	Building for Life	39
<b>A2</b>	The needs and range of users: inclusive design	39
<b>A3</b>	Appraisal	44
<b>3.2</b>	<b>Neighbourhoods</b>	<b>55</b>
<b>N1</b>	<b>Neighbourhoods and centres</b>	<b>56</b>
<b>N1.1</b>	Facilities and services	57
<b>N1.2</b>	Accessibility	58
<b>N1.3</b>	Neighbourhoods, density and location	59
<b>N1.4</b>	Community focal points	60
<b>N1.5</b>	Recreation, public open space and other landscape dominant uses	61

	<b>N2</b>	<b>Character</b>	<b>62</b>
	N2.1	Character areas	65
	N2.2	Specific features	66
	<b>N3</b>	<b>Local resources, energy and carbon dioxide reduction</b>	<b>67</b>
	N3.1	Renewable and low carbon energy sources	67
	N3.2	Solar	68
	N3.3	Wind	69
	N3.4	Microclimate	70
	N3.5	Utilities infrastructure	71
	N3.6	Surface water drainage	71
	N3.7	Waste recycling and collection	72
	<b>N4</b>	<b>Green infrastructure, vegetation and habitat</b>	<b>73</b>
	N4.1	Existing landscape features, vegetation and habitat	74
	N4.2	The landscape framework	74
	<b>N5</b>	<b>Street pattern and movement structure</b>	<b>75</b>
	N5.1	Route and place hierarchy	76
	N5.2	Walkable neighbourhoods	77
	N5.3	Public transport	78
	N5.4	Cycling	79
	N5.5	Parking strategy	80
	N5.6	Streets and centres	81
	N5.7	Connected streets	81
	<b>N6</b>	<b>Townscape, topography and views</b>	<b>83</b>
	N6.1	Townscape	83
	N6.2	Topography	81
	N6.3	Views	82
	<b>N7</b>	<b>The public realm, open space network and legibility</b>	<b>86</b>
<b>3.3</b>		<b>Streets</b>	<b>87</b>
	<b>S1</b>	<b>The street as a whole</b>	<b>88</b>
	S1.1	Fronts and backs	89
	S1.2	Streets as places	89
	S1.3	Main components of the street	90
	S1.4	Management and maintenance	91
	S1.5	General kinds of street	91

# Detailed contents

	S1.6	Character and variation	92
	S1.7	Spatial enclosure	94
	S1.8	Defining the public and private realms	95
	S1.9	Creating a sense of integration	96
	<b>S2</b>	<b>Street spaces and the public realm</b>	<b>97</b>
	S2.1	Street space types	97
	S2.2	Continuous access	99
	S2.3	Vehicle speed	100
	S2.4	Flexibility and adaptability	101
	S2.5	On-street parking	102
	S2.6	Sustainable drainage systems	103
	S2.7	Street trees and other planting	103
	S2.8	Street lighting, street furniture and public art	104
	S2.9	Surface materials	106
	S2.10	Services and utilities	106
<b>3.4</b>		<b>Plots, blocks and buildings</b>	<b>107</b>
	<b>B1</b>	<b>Plot series and streets</b>	<b>108</b>
	B1.1	Plot series and slopes	109
	B1.2	The perimeter block	110
	B1.3	Using the interior of blocks	112
	B1.4	Block size and shape	114
	B1.5	Density	115
	B1.6	Off-street parking	116
	<b>B2</b>	<b>Buildings in their plots</b>	<b>118</b>
	B2.1	Choose the right building types: variety and variation	118
	B2.2	Variants and special types	119
	B2.3	Choice of type and energy use	120
	B2.4	Relationship of the building to the public realm	121
	B2.5	Private and shared private outdoor space	122

<b>B3</b>	<b>Building design</b>	<b>123</b>
<b>B3.1</b>	Overall building form	123
<b>B3.2</b>	Internal space standards	123
<b>B3.3</b>	Roof form	124
<b>B3.4</b>	Openings and articulation	124
<b>B3.5</b>	Installations, equipment and storage	125
<b>B3.6</b>	Materials and colour	125
<b>4</b>	<b>TECHNICAL REQUIREMENTS</b>	<b>128</b>
<b>4A</b>	Space standards	129
<b>4B</b>	Street and parking geometry	133
<b>4C</b>	Drainage	155
<b>4D</b>	Highway structures	162
<b>4E</b>	Street lighting	165
<b>4F</b>	Public utilities	167
<b>4G</b>	Street trees	170
<b>4H</b>	Materials	184
<b>4I</b>	Signage and street furniture	187
<b>4J</b>	Adoption of highways	189
<b>4K</b>	Construction waste	194
<b>4L</b>	Management	195
<b>Ap</b>	<b>APPENDICES</b>	<b>197</b>
<b>Ap1</b>	Core principles	199
<b>Ap2</b>	Table of supporting policies	203
<b>Ap3</b>	Glossary of terms	217
<b>Ap4</b>	Relevant publications	225
<b>Ap5</b>	Key contacts and addresses	229
<b>I</b>	<b>INDEX</b>	<b>233</b>
	Acknowledgement	236



# Introduction



## 1.1 Who should use the Guide?

**This Guide is for use by residential developers and their design professionals, consultants and agents in formulating designs and making applications for planning permission for residential development in South Yorkshire.**

It is intended to provide a clear and consistent approach to design in the development management process – an approach that will result in higher quality neighbourhoods and efficiency savings for developers.

It will be used by the four South Yorkshire local authorities to support their assessment of proposals. It incorporates both their planning and highway responsibilities.

The four authorities are:

- Barnsley Metropolitan Borough Council
- Doncaster Metropolitan Borough Council
- Rotherham Metropolitan Borough Council
- Sheffield City Council

## 1.2 What scale of development is covered by the Guide?

The Guide is underpinned by the principles in Building for Life (BfL), which apply to developments of 10 or more dwellings. The full set of design guidelines in Section 3 therefore apply specifically to all proposals of ten or more dwellings. Many of the design guidelines are appropriate to smaller developments and the guidelines and assessment criteria in this Guide will be used as the main point of reference when assessing schemes of less than ten dwellings.

## 1.3 Status of the Guide

The Guide complements and supports the policies in the Development Plan Documents (DPD) of the Local Development Frameworks (LDF) of each of the local authorities. It has been prepared in accordance with Regulation 17 of the Planning Regulations 2004 (as modified by the Planning Act 2008).

The status of this document within each local authority is as follows:

- **Barnsley MBC** – Best Practice Guidance, pending consideration of its adoption as a Supplementary Planning Document following adoption of the LDF Core Strategy
- **Doncaster MBC** – Supplementary Planning Document
- **Rotherham MBC** – Best Practice Guidance, pending consideration of its adoption (all or in part) as a Supplementary Planning Document following adoption of the LDF Core Strategy
- **Sheffield CC** – Best Practice Guidance

## 1.4 Where to find what you need

The Guide has five parts:

1. This Introduction.
2. Working with the Guide
3. Design principles
4. Technical requirements
- A. Appendices

Each part presents a facet of the same overall effort to improve the quality of residential design in South Yorkshire. While there is significant benefit in reading the whole guide, once you become familiar with the overall structure, you might approach it in different ways depending on your immediate needs.

**Working with the Guide**

**Section 2** is a guide to the **development management process**. It sets out:

- What developers should submit as part of their pre-application proposals and their subsequent planning application
- The material and **evidence** required to support proposals
- The **criteria** that the local authorities will use to evaluate and assess proposals.

Design teams should refer to this section on an ongoing basis to assess their own work against the criteria and anticipate the formal assessment process. The Local Planning Authorities (LPA) will use this section to support their assessment.

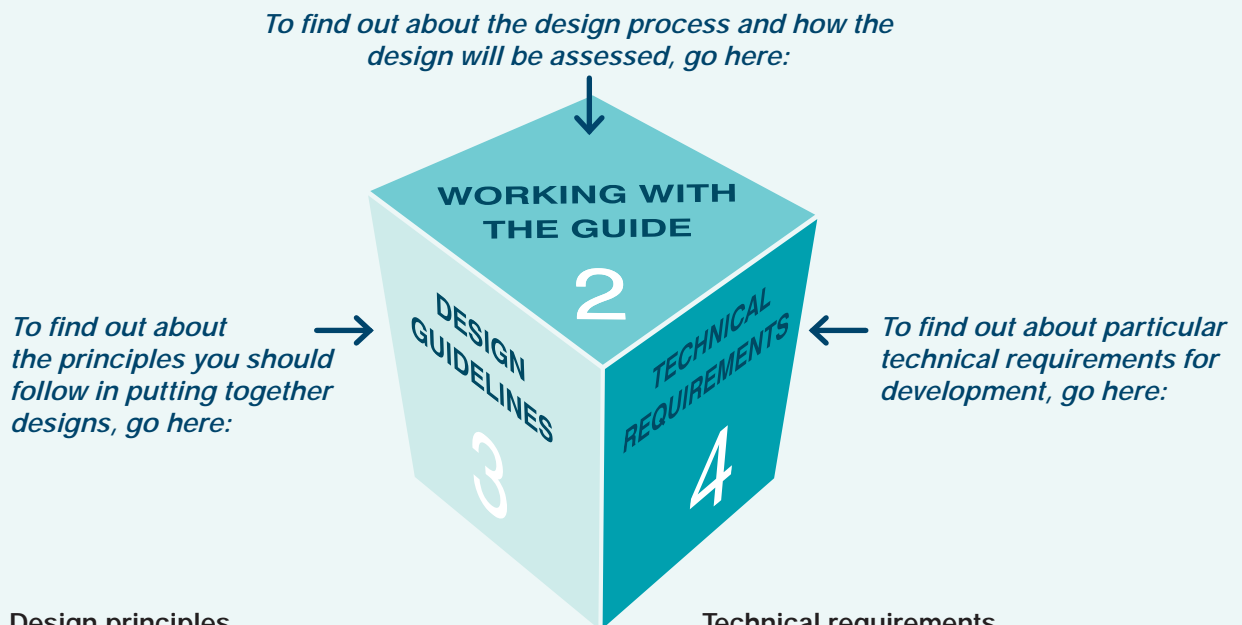

**Design principles**

**Section 3** sets out the detailed **design guidelines**. These are the principles that each of the Local Authorities will expect proposals to follow to meet the criteria.

The design team may want to start here at the outset and cross-check their work against the assessment criteria as the design is developed. The LPAs will also use this section in their assessments.

**Technical requirements**

The **Technical requirements, parameters and standards** in Section 4 expand on the design guidelines with further, specific detail.

Design teams should use this section to understand the implications of their design concept and/or to finalise the details toward the end of the process. The LPA and Local Highway Authority will refer to this section in checking through detailed proposals, which will normally be the subject of planning conditions.

Illustrations and diagrams are used to help show how the design guidelines can be applied in a way that is specific to South Yorkshire.

## 1.5 The Purpose of the Guide

The Guide is a new version of *Better Places to Live in South Yorkshire* which was published in 2004. It takes those ideas forward and recasts them with the benefit of over six years of experience, taking into account significant changes to the planning system and national planning guidance.

The main force of the changes is to put even greater emphasis on sustainability, accessibility, local distinctiveness and quality in design.

It also reflects the emergence of Local Development Frameworks in South Yorkshire, which in their Core Strategies, have a much clearer and sharper focus on design quality and sustainability than the previous Unitary Development Plans.

To support the LDF process, Transform South Yorkshire undertook a design quality audit in 2008 of recently completed housing developments in South Yorkshire, using the Building for Life methodology. Despite *Better Places to Live*, this showed that 66% of developments were assessed as 'poor', compared with 29% nationally.

Amongst the reasons for the poor quality were:

- Standard house designs and estate layouts applied without regard to context or local character
- Unsatisfactory car parking
- Rigid adherence to standard plans and methods of construction
- Inadequate communal spaces

At the same time, developers have complained about a lack of consistency of approach between the South Yorkshire local authorities, and by different Departments within them. They also have concerns about the level of understanding by the Local Authority of the development and financial pressures faced by developers.

The purpose of this Guide is therefore to address each of these issues. It provides clarity and certainty to the development industry, and a set of guidelines and technical criteria, which if complied with, will result in higher quality and more sustainable residential developments. The Guide seeks, through inclusive design standards, to foster a common understanding between the local authorities and the development industry of what high quality means and what is necessary to achieve it.

The outcome will be places that are:

- integrated into the surrounding environment
- vital, active and well managed
- equitable, cohesive, inclusive, safe and secure
- local, distinctive and attractive
- efficient, flexible and adaptable.

Together, these constitute the characteristics of sustainable development.

## 1.6 The policy context and Building for Life

The Guide reflects current national policies and advice, in particular PPS1 and PPS 3, and supports the policies in the approved and emerging Local Development Frameworks of the four South Yorkshire local authorities, as expressed in their Development Plan Documents. The relevant supporting LDF (or saved UDP where appropriate) policies are set out in Appendix 2.

In addition, all the technical criteria, parameters and standards in Section 4 (Technical Requirements) have been approved by each local authority.

Specific reference throughout the Guide is made to a number of nationally recognised design criteria and standards. These are:

- Building for Life
- Lifetime Neighbourhoods
- Manual for Streets.
- Code for Sustainable Homes
- Lifetime Homes
- Safer Places.

Particular importance is placed on the Building for Life standards, and the Guide uses the BfL framework to underpin its approach. Section 2 explains this in more detail, and Section 3 sets out how BfL is used to define the Guide's 'core principles'. Emphasis is also placed on inclusive design as an essential part of achieving equitable and inclusive places and the goal of Lifetime Neighbourhoods.

Section 2 of the Guide also sets out the role that Design and Access Statements play in the application process and their importance in demonstrating how the detailed design policies and guidelines are being addressed.



# Working with the guide 2

## 2.1 Criteria for design quality: Building for Life

As stated in Section 1, a central element of the South Yorkshire approach is the Building for Life assessment developed by Design for Homes, CABI and the Home Builders Federation. A Building for Life assessment checks proposals against a set of twenty design criteria in order to judge the quality of the proposal. The Building for Life assessment process will be used as the basis for judging the quality of submissions for residential planning permission in South Yorkshire.

In order to achieve high quality residential environments, all new development of ten or more dwellings in South Yorkshire will be required to achieve a score of at least Good (Silver) in a Building for Life assessment. See section 2.11 and 3.1, A1 for more detail.

## 2.2 What are the main stages in the design and assessment process?

1. Initial vision
2. Concept development
3. Application submission

Section 2.10 describes the main stages in more detail and sets out what is required with respect to design at each stage. This is 'best practice' for developers and their design teams and will also enable the local authorities to provide an efficient and effective service.

## 2.3 How is each stage dealt with?

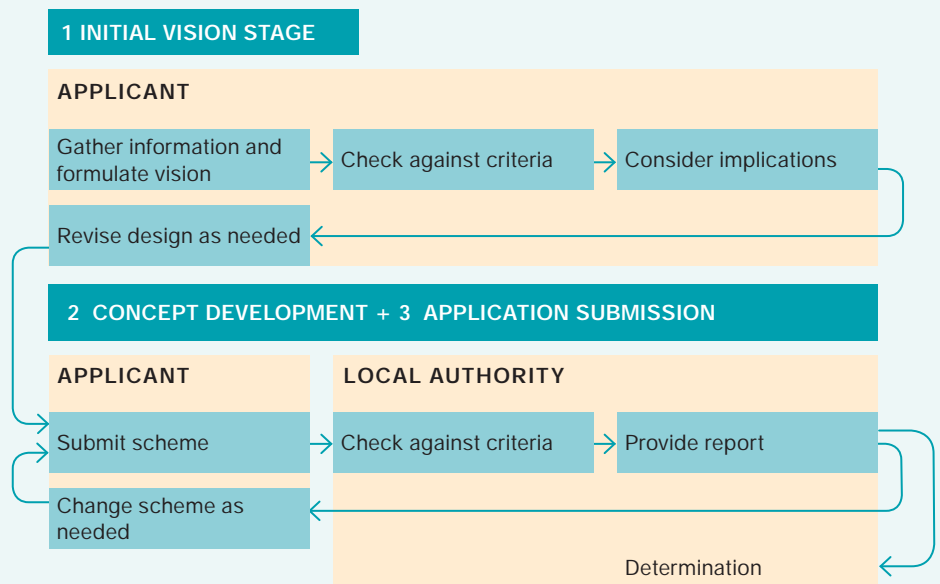

Submitting information to the Local Planning Authority at the concept stage is optional but highly recommended. A concept stage submission helps the applicant to understand the views of the LPA on how the design criteria apply to the site and the acceptability of the concepts. Providing information early in the process can help reduce the cost of submissions by avoiding the need for changes late in the process when more detail has been worked up.

## 2.4 How much information is required?

The material submitted should be proportionate to the size of the scheme and appropriate to the stage in the process. Small, less complex schemes, in particular those of less than ten dwellings, will require less information than larger schemes. Early submissions will require less information and less detail than the application stage. The local authorities can advise on the amount of information they require, with reference to the Guide.

## 2.5 Which criteria and guidelines apply to smaller schemes?

Not all the assessment criteria and guidelines apply to smaller scale development. The criteria for the Concept stage (Section 2.10) are the most relevant for small schemes. Also look in Section 2.11 which indicates which of the criteria are most important for schemes of less than ten dwellings.

The Guidelines in Section 3 that apply most directly to smaller schemes can be found at 3.3, on the Street (Guidelines beginning with an S), and 3.4, on Buildings (Guidelines beginning with a B). Some of the Building for Life criteria will also refer to 3.2 on the Neighbourhood.

## 2.6 How does the Building for Life assessment work?

The Building for Life assessment is in effect a 'quality audit'. The assessment criteria are posed as questions about the design of the scheme. A summary of the questions is included on page 17 to 33. The information about the proposed scheme, including written work and drawings, is examined in order to answer the questions. The answers take the form of a score for each question, which are compiled to give an overall ranking.

There are two forms of assessment, informal and formal. An informal assessment can be carried out by the design team as part of the design process and production of the Design and Access Statement.

In South Yorkshire, a formal design stage assessment will normally be carried out by the local authority as part of determining the application.

Local authorities are also required to undertake assessments of completed schemes of 10 or more dwellings.

## 2.7 Who does the Building for Life assessment?

On major schemes (ten or more dwellings), a Development Team approach will be taken for the assessment. The Team will be set up for the life of the application pulling together all the key officers and agencies that have a regulatory role in the application. The leader of the Team will normally be the Development Management officer who is the case officer for the application. The aim is to consider the full range of issues and concerns of the different disciplines and arrive at a view that balances those concerns and results in the best quality scheme overall. Submissions will be assessed against the same criteria and guidance jointly by the Development Team.

On smaller schemes, the case officer or another officer within the team will undertake the assessment and provide the results and response from the other relevant officers.

## 2.8 What are the criteria and how are they scored?

Section 2.11 sets out in detail the Building for Life criteria that will be used by the local authority when assessing designs submitted for planning permission. The Building for Life Questions are set out one or two per page along with the following additional information:

- Further questions to clarify the main question
- The evidence that needs to be submitted in order to assess the design
- The relevant guidance within the Guide and external sources

Each of the criteria will be scored 1, 0.5 or 0.

### SCORE of 1

Awarded where there is sufficient evidence that the proposed design will meet this criterion.

### SCORE of 0.5

Awarded where there are specific areas where the proposed design performs well against the criterion but there are also others where it fails to do so. This option is not to be used as a fallback where the design is generally unclear or unconvincing. If there is uncertainty about the scheme's ability to meet the criterion, it should be awarded a score of 0.

### SCORE of 0

Awarded where it is unclear whether the proposed design will meet the criterion or if you're certain it will fail to meet the criterion.

#### Building for Life scores fall in to the following grades:

16 or more	: Very good (Gold)
14 - 15.5	: Good (Silver)
10 - 13.5	: Average
9.5 or fewer	: Poor

For more information on assessments. See:

 *Evaluating housing proposals step by step (CABE, 2008)*  
[www.buildingforlife.org](http://www.buildingforlife.org)

## 2.9 Design and Access Statements

All submissions are required to include a Design and Access Statement\*. The Design and Access Statement should be started at the beginning of the process and filled out progressively through the process.

Because the main reference criteria for assessing proposals will be the twenty Building for Life questions, we recommend that your design process is geared to address those questions. It is also recommended that the supporting material in the Design and Access Statement is similarly geared to answer the Building for Life Questions.

The design process also needs to be geared towards adopting inclusive design standards throughout. The access component of the Design and Access Statement needs to demonstrate how the standards have been applied.

In order to meet the requirements set out in *Guidance on information requirements and validation* (DCLG March 2010) on the information to be provided in a Design and Access Statement, the answers to the Building for Life questions should be grouped under the headings in the DCLG Guidance.

Design and Access Statement headings	Relevant Building for Life Criteria
Use	1,2,3
Amount	1,2,3
Layout	6,7,8,9,10,11,12,15,16,17
Scale	6,8,17
Landscape	6,7,8,16
Appearance	6,8,17
Access	4,13,14

Some of the Building for Life criteria do not fit obviously into any of the Design and Access Statement headings and so should be included under other headings as appropriate.

The requirement to include a context appraisal in the Design and Access Statement as indicated in the *Guidance on information requirements* should be satisfied by completing the appraisal work set out in Section A3, below.

\* Exceptions include: development of a single dwelling house or development within its curtilage incidental to the enjoyment of the dwelling; change of use not involving change of operations; extension of time limits.

## 2.10 Design Stage Checklists

The following pages set out in more detail the design stages identified in 2.2. They include information on the material to be submitted at each stage, the assessment criteria that will be used at each stage and the way the Local Planning Authority will respond to the submissions.

At each stage, contact the local planning authorities for advice on the scope of information required for a given site. Requirements will vary depending on the type of application to be submitted and the scale of the proposed development.

**Initial Vision Checklist**

This is the starting point of the design process. The more that is done at this stage to meet the criteria, the easier it will be to go through the Concept and Application stages and the fewer changes that are likely to be needed later on.

**What information should I get together?**

Contact the local planning authorities for advice on the scope of the information required for a given site. The work done at this stage can and should make a valuable contribution to the Design and Access Statement for both the Concept and Submission stages.

**All applications**

**Text**

- Size of site (in hectares)
- Use and amount of proposed development (number of dwellings and likely density, land areas of non-residential uses)
- Type and tenure of housing

**Drawings**

- Site location plan, including surrounding area up to 150 metres around the site
- Simple concept sketch showing:
  - Potential points of access to the site
  - General arrangement of land uses (including open space)
  - General location of buildings

**10 or more dwellings (in addition to the above)**

**Text**

- Environmental Impact Assessment Screening and/or Scoping requests sent to the Local Planning Authority with Scoping Report
- Housing need and demand information

**Drawings**

- Principal movement routes surrounding the development
- Nearest neighbourhood facilities and transport stops

**What are the criteria that apply at this stage?**

For details see pages 17 to 33

- 1 Does the development provide for or allow for community facilities?
- 2 Is there an accommodation mix that reflects the needs of the community?
- 3 Is there a tenure mix that reflects the needs of the community?
- 4 Does the development have easy access to public transport?
- 5 Is the design specific to the scheme (the location and its character)?
- 6 Does the scheme integrate with existing streets, paths and development?

**Other Considerations**

Check what the policies in the development plan documents say about the site and the requirements that may apply to it.

As far as possible, work with the local community to find a solution that suits the area.

This column states what the **developer** needs to do and the information that needs to be submitted.

The right hand column sets out the **Building for Life** evaluation criteria relevant to the information on design stage in the process. The evaluation criteria are set out in more detail at the end of this section on pages 17 to 33.

The bottom row sets out further considerations and how the **Local Planning Authority** will respond and what it will do in the process.

## Initial Vision Checklist

This is the starting point of the design process. The more that is done at this stage to meet the criteria, the easier it will be to go through the Concept and Application stages and the fewer changes that are likely to be needed later on.

### What information should I get together?

Contact the local planning authorities for advice on the scope of the information required for a given site.

The work done at this stage can and should make a valuable contribution to the Design and Access Statement for both the Concept and Submission stages.

### All applications

#### Text

- Size of site (in hectares)
- Use and amount of proposed development (number of dwellings and likely density, land areas of non-residential uses)
- Type and tenure of housing

#### Drawings

- Site location plan, including surrounding area up to 150 metres around the site
- Simple concept sketch showing:
  - Potential points of access to the site
  - General arrangement of land uses (including open space)
  - General location of buildings

### 10 or more dwellings (in addition to the above)

#### Text

- Environmental Impact Assessment Screening and/or Scoping requests sent to the Local Planning Authority with Scoping Report
- Housing need and demand information as available from the LPA

#### Drawings

- Principal movement routes surrounding the development
- Nearest neighbourhood facilities and transport stops

### What are the criteria that apply at this stage?

For details see pages 17 to 33

- 1 Does the development provide (or is it close to) community facilities?
- 2 Is there an accommodation mix that reflects the needs of the community?
- 3 Is there a tenure mix that reflects the needs of the community?
- 4 Does the development have easy access to public transport?
- 6 Is the design specific to the scheme (the location and its character)?
- 14 Does the scheme integrate with existing streets, paths and development?

### Other Considerations

Check what the policies in the development plan documents say about the site and the requirements that may apply to it.

As far as possible, work with the local community to find a solution that suits the area.

## Concept Development Checklist

The concept development stage starts to add detail to the proposal. It begins to resolve technical matters that may affect the layout and begins to add information about the overall structure and general look and feel of the scheme. At this stage, a submission can be made to the LPA who will provide a written response and/or arrange a meeting to go through the concept proposal.

### What information should be submitted?

Contact the local planning authorities for advice on the scope of the information required for a given site.

The information compiled at this stage is best submitted in the form of a draft or outline Design and Access Statement, which should include the work done on the Initial Vision.

### All applications

#### Text (draft Design and Access Statement)

- Size of site (in hectares)
- Use and amount of proposed development (number of dwellings and likely density, land areas of non-residential uses)
- Table giving quantities of dwelling type, size and tenure
- Table of accessibility for key facilities (and/or show on plans)
- Appraisal required by the Local Authority covering the topics set out in Section 3.1, A3

#### Drawings

- Site location plan
- Appraisal drawings
- Concept sketches showing:
  - Points of access to the site and key public transport routes,
  - Outline movement pattern and parking proposals
  - Arrangement of retained features and land uses (including open space and ownership) and drainage strategy
  - Layout, massing and type of buildings and spaces
  - Illustrative building and street elevations with general types of materials proposed.

### 10 or more dwellings (in addition to the above)

#### Text

- Housing need and demand information as available from the LPA

#### Drawings

- Principal street sections
- Outline public realm and landscape design proposals
- Typical house plans

All drawings should be drawn and reproduced at a scale that will enable the proposals to be assessed (1:500 or larger for detailed areas). Plans should have a north arrow and show the immediate surroundings of the site normally extending 150m from the boundary.

### What are the criteria that apply at this stage?

For details see pages 17 to 33

- 2 Is there an accommodation mix that reflects the needs of the community?
- 3 Is there a tenure mix that reflects the needs of the community?
- 5 Does the development have any features that reduce its environmental impact?
- 6 Is the design specific to the scheme (the location and its character)?
- 7 Does the scheme exploit existing buildings, landscape or topography?
- 10 Are streets defined by a well-structured building layout?
- 12 Is the car parking well integrated and situated so it supports the street scene?
- 14 Does the scheme integrate with existing streets, paths and development?
- 15 Are public spaces and pedestrian routes overlooked and do they feel safe?
- 17 Do buildings exhibit architectural quality?

### What will the local authority do?

The Local Authority will identify a case officer and assemble a development team to appraise the proposals against the BfL questions and provide a written response including:

- Views on the principle and details of the proposal (as far as the information submitted allows) from the Local Authority, consultees and design review panels (as appropriate)
- Requirements or suggestions for amendments to the proposals
- Advice on community consultation
- Identification of any areas to be covered by a Planning Obligation
- Identification of further information and/or supporting submissions required with the application (and their scope and content)
- Identification of any further information required or the need for additional pre-application meetings and/or assessment.

## Application Submission Checklist

The application submission represents the culmination of the design process for the planning stage. Submissions will be assessed against the same criteria by the different relevant disciplines who will work together to provide an integrated response. The aim is to consider the issues and concerns of the different disciplines and arrive at a view that balances those concerns and results in the best quality scheme overall.

### What information should be submitted?

Contact the local planning authorities for advice on the scope of the information required for a given site. Requirements will vary depending on the type of application to be submitted and the scale of the proposed development.

All the appraisal work done at this stage, as well as the Initial Vision and Concept work, should contribute to and help fulfil the requirements for the Design and Access Statement

#### All applications

**Text (Design and Access Statement)** including the following elements:

- Size of site (in hectares)
- Use and amount of proposed development (number of dwellings and likely density, land areas of non-residential uses)
- Housing need and demand information as available from the LPA
- Table giving quantities of dwelling type, size and tenure
- Table of accessibility for key facilities (and/or show on plans)
- Appraisal required by the Local Authority covering the topics set out in Section 1.3 A3

**Code for Sustainable Homes** design stage assessment results in part or whole as agreed with the Local Planning Authority.

**Depending on the location, size and nature of the proposed development and subject to discussion with the local planning authority, the full range of supporting information may include:**

- Affordable housing statement
- Biodiversity survey and report
- Tree survey
- Consultation statement
- Flood risk assessment
- Heritage statement
- Noise impact assessment
- Open space assessment
- Planning obligations (draft)
- Sustainability statement
- Town centre use assessment
- Transport assessment
- Safety audit

(continued on next page)

### What are the criteria that apply at this stage?

For details see pages 17 to 33

#### Environment and Community

- 1 Does the development provide (or is it close to) community facilities?
- 2 Is there an accommodation mix that reflects the needs of the community?
- 3 Is there a tenure mix that reflects the needs of the community?
- 4 Does the development have easy access to public transport?
- 5 Does the development have any features that reduce its environmental impact?

#### Character

- 6 Is the design specific to the scheme (the location and its character)?
- 7 Does the scheme exploit existing buildings, landscape or topography?
- 8 Does the scheme feel like a place with a distinctive character?
- 9 Do the buildings and layout make it easy to find your way around?
- 10 Are streets defined by a well-structured building layout?

#### Streets

- 11 Does the building layout take priority over the streets and car parking, so that the highways do not dominate?
- 12 Is the car parking well integrated and situated so it supports the street scene?

- 13 Are the streets pedestrian, cycle and vehicle friendly

(continued on next page)

## What information should be submitted? (continued)

### All applications

#### Drawings

- Site location plan
- Appraisal drawings
- Masteplan drawings including:
  - Points of access to the site and key public transport routes
  - Movement pattern and parking proposals
  - Retained features and land uses, including open spaces
  - Layout, including building form, height and orientation; garden spaces; levels and retaining structures
- Building plans and elevations and/or street elevations (1:50-1:100) including materials, features and dimensions demonstrating policy compliance (if required) for Lifetime Homes, space standards, Mobility housing and/ or wheelchair housing criteria.
- Typical building details (1:10-1:50)

#### 10 or more dwellings (in addition to the above)

- Movement and highway design proposals showing inclusive design along with street types, vehicle tracking check and proposals to ensure design speeds are met
- Public realm and landscape design proposals including the areas to be adopted by the highway authority, entry points of adjacent dwellings, levels, street furniture, the position and type of boundaries, street lighting, street trees and typical materials
- Street sections and/or site sections showing finished floor and site levels (1:100-1:500)
- Typical details of streets, spaces and planting (typically 1:50-1:100)
- Typical details of speed reduction features, crossings and cycle parking (1:50-1:100)
- Visualisations and consultation material

All drawings should be drawn and reproduced at a scale that will enable the proposals to be assessed (1:500 or larger for detailed areas). Plans should have a north arrow and show the immediate surroundings of the site normally extending 150m from the boundary

## What are the criteria that apply at this stage? (continued)

For details see pages 17 to 33

- 14** Does the scheme integrate with existing streets, paths and development?
- 15** Are public spaces and pedestrian routes overlooked and do they feel safe?
- Design and Construction**
- 16** Is public space well designed and does it have suitable management arrangements in place?
- 17** Do buildings exhibit architectural quality?
- 18** Do internal spaces and layout allow for adaptation, conversion and extension? (see Lifetime Homes)
- 19** Has the scheme made use of advances in construction or technology that enhances its performance, quality and attractiveness?
- 20** Do buildings or spaces outperform statutory minima such as building regulations?

## What will the local authority do?

### In response to the submission, the Local Planning Authority will:

- Undertake the assessment of the proposal
- Process comments and information requests from consultees
- Request in writing any further information required
- Provide written response including
  - Views on the design and details of the proposal from case officers, consultees and design review panels (as appropriate)
  - Requirements or suggestions for amendments to the proposals
  - Confirmation of deadlines for submission of any additional information
- Review and audit any further information amendments and respond as above and/or meet with applicant to discuss the need for any further changes or additional information
- Publish amendments as necessary for additional public consultation
- Review and audit the final proposal
- Process the application for determination

## 2.11 The Building for Life Assessment Sheets

The following pages set out in more detail the Building for Life criteria that will be used to assess proposals.

The criteria are set out as questions. For each question, the following pages also add:

- Further questions to clarify the main question
- The evidence that needs to be submitted in order to assess the design
- The relevant guidance within the Guide and external sources.

*The main Building for Life question with its original reference number*

*Further questions to clarify and add detail to the main question*

*Guidance reference to design policies within the Guide and to external documents that provide guidance on how to meet the design criteria in the questions*

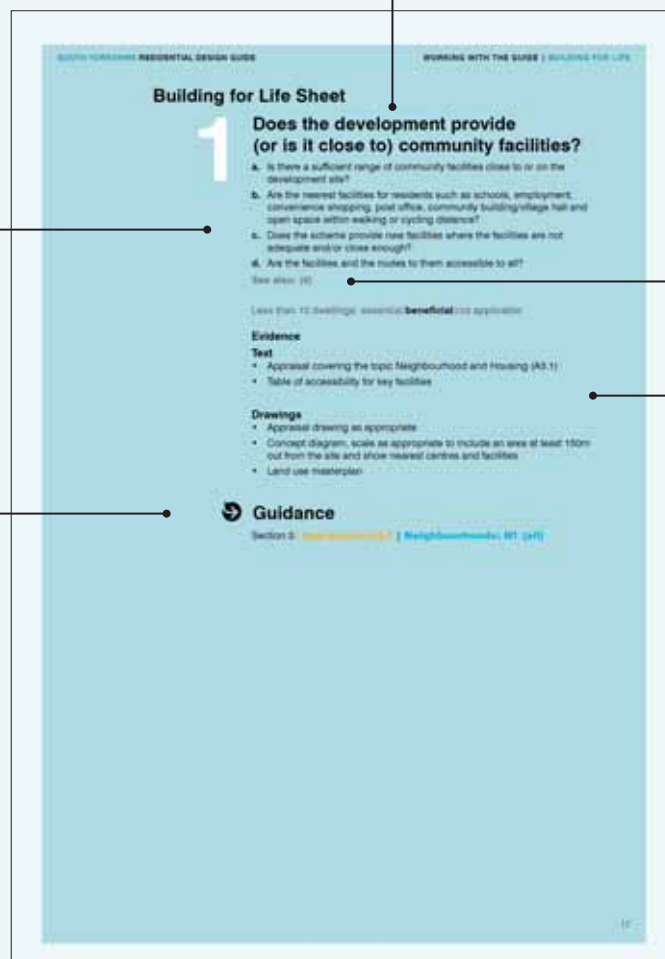

*Related topic and question reference number*

*Evidence sets out the information that should be submitted to demonstrate all the questions have been adequately answered*

## Building for Life Sheet

# 1

### Does the development provide (or is it close to) community facilities?

- a. Is there a sufficient range of community facilities close to or on the development site?
- b. Are the nearest facilities for residents such as schools, employment, convenience shopping, post office, community building/village hall and open space within walking or cycling distance?
- c. Does the scheme provide new facilities where the facilities are not adequate and/or close enough?
- d. Are the facilities and the routes to them accessible to all?

See also: (4)

Less than 10 dwellings: **essential**/beneficial/not applicable

#### Suggested evidence

##### Text

- Appraisal covering the topic Neighbourhood and Housing (A3.1)
- Table of accessibility for key facilities

##### Drawings

- Appraisal drawing as appropriate
- Concept diagram, scale as appropriate to include an area at least 150m out from the site and show nearest centres and facilities
- Land use masterplan



### Guidance

Section 3: [Appraisal: A3.1](#) | [Neighbourhoods: N1 \(all\)](#)

## Building for Life Sheet

# 2

### Is there an accommodation mix (type and size) that reflects the needs of the community?

- What is the housing need and demand for the area?
- Does the proposed mix of housing offer choice and meet needs and demands?
- Are housing types and sizes distributed appropriately within the site?
- Has Mobility Housing and Wheelchair accessible housing been included?
- What evidence is provided to support the proposed mix of type and size?

# 3

### Is there a tenure mix that reflects the needs of the community?

- What is the tenure need and demand for the area?
- Does the proposed mix of tenure offer choice and meet needs and demands?
- Is the layout and design 'tenure blind'?
- What evidence is provided to support the proposed mix of type and size?

Does the mix of type, size and tenure help support a mixed and balanced community on the site and in the wider neighbourhood?

Less than 10 dwellings: **essential**/beneficial/not applicable

#### Suggested evidence

##### Text

- Appraisal covering the topic Neighbourhood and Housing (A3.1)
- Table giving quantities of type, size and tenure

##### 10 or more dwellings

- Affordable housing statement or
- Social and Economic chapter of Environmental Statement as required by the Local Planning Authority

##### Drawings

- Illustrative and/or Detailed layout showing distribution of affordable housing, wheelchair accessible housing and housing which is readily adaptable for residents who are wheelchair users.
- Building plans (1:50-1:100)

## Guidance

Housing policies

Section 3: **Buildings: B1.5 | B2.1 | B2.2**

Discussions with the Local Authority

## Building for Life Sheet

# 4

### Does the development have easy access to public transport?

- a. What are the nearest public transport services and where do they go?
- b. Does the scheme meet accessibility criteria?
- c. Are the nearest stops within 400m of all dwellings?
- d. Are stops and the routes to them accessible to all? (including resting places)?
- e. Does the scheme extend or provide new transport services where necessary?

See also: (1)

Less than 10 dwellings: **essential**/beneficial/not applicable

#### Suggested evidence

##### Text

- Appraisal covering the topic Access, transport and street patterns (A3.4)
- Table of accessibility for key facilities (same as for criterion 1) (see N1.2)

##### 10 or more dwellings

- Transport Assessment as required by the Local Planning and Highway Authority

##### Drawings

- Appraisal drawing as appropriate
- Concept diagram, of a scale appropriate to show transport routes and stops (could be combined with centres and facilities (1))
- Illustrative and/or detailed layout showing location of bus stops and routes to them



### Guidance

Section 3: [Appraisal: A3.4](#) | [Neighbourhoods: N1 \(all\)](#) | [N5](#) | [N5.3](#)  
Discussions with Local Planning and Highway Authority and South Yorkshire Transport Executive

## Building for Life Sheet

# 5

### Does the development have any features that reduce its environmental impact?

- a. Are streets and buildings arranged for optimum microclimate, passive solar heating and natural ventilation while still achieving other guidelines for the design of streets?
- b. Have areas of habitat been retained, extended or created to maintain or increase the number of species on the site?
- c. Does the scheme help to reduce surface water run-off?
- d. Does the scheme provide renewable energy?

Does the development achieve the Code for Sustainable Homes level 3 or better?

Less than 10 dwellings: **essential**/beneficial/not applicable

#### Suggested evidence

##### Text

- Appraisal covering the topic Renewable energy, CO<sub>2</sub> and other local resources (A3.3)
- Indicative strategy or sustainability statement for renewables and carbon reduction, drainage strategy,
- Code for Sustainable Homes design stage assessment results
- Sustainability Statement

##### Drawings

- Illustrative or detailed layout plan and building types identifying features that contribute to the sustainability strategy (1:500)



## Guidance

Section 3: **Appraisal: A3.3 (all)** | **Neighbourhoods: N3 (all) | N4 (all) | N5 | N5.3 | N5.4** | **Buildings: B2.3 | B2.4 | B3 (all)**

Section 4: **Technical requirements: 4C | 4G | 4K**

Code for Sustainable Homes Technical Guide

## Building for Life Sheet

# 6

### Is the design specific to the scheme (the location and its character)?

- a. Have adequate appraisals been done to inform the design?
- b. Does the scheme work well within the neighbourhood, landscape and topography?
- c. Does it make the most beneficial and efficient use of the site's opportunities and constraints?
- d. Does the design use standard elements or has it been designed to fit and respond to the particular circumstances (specific features and characteristics)?

See also: (14)

Less than 10 dwellings: **essential**/beneficial/not applicable

#### Suggested evidence

##### Text

- Appraisal covering the topics Character (A3.2) and Built form, townscape, topography and views (A3.6)

##### Drawings

- Appraisal drawings as appropriate showing existing features including topography within and surrounding the site
- Concept diagram and/or illustrative or detailed layout (1:500-1:1250, including an area at least 150m out from the site) showing main entrance and orientation (fronts and backs) of existing buildings, disposition of built areas and open space and any other uses
- Street sections and/or site sections showing finished floor and site levels (1:100-1:500)
- Building plans and elevations and/or street elevations (1:50-1:100)
- Typical details of streets, spaces and landscape planting (typically 1:50-1:100)

## Guidance

Section 3: [Appraisal: A3 \(all\)](#) | [Neighbourhoods: N1 \(all\)](#) | [N2 \(all\)](#) | [N4 \(all\)](#) | [N5](#) | [N5.1](#) | [N5.6](#) | [N5.7](#) | [N6 \(all\)](#) | [Streets: S1 \(all\)](#) | [Buildings: B1.2](#) | [B1.6](#) | [B2.1](#) | [B2.2](#) | [B3 \(all\)](#)

If the scheme creates new streets see also

Section 3: [Streets: S2 \(all\)](#)

Section 4: [Technical requirements: 4B](#) | [4E](#) | [4G](#) | [4H](#) | [4I](#)

Manual for Streets: Section 4, 5

## Building for Life Sheet

# 7 Does the scheme exploit existing buildings, landscape or topography?

- Do the appraisals adequately account for the existing features on the site and its surroundings?
- Are positive existing features within the site retained, protected and enhanced and well integrated within the design?
- Does the proposal help to reinforce and extend surrounding landscape features and green infrastructure?
- Does the scheme properly address, protect and enhance surrounding positive development, natural features and heritage assets?
- Are views out, views in and roofscape fully exploited, in particular with reference to topographic position and orientation?

Key existing features (not exhaustive): Topography/landform and earthworks; watercourses and water bodies; vegetation, trees, hedgerows; boundaries, access points, rights of way, footpaths, tracks and other routes; buildings and other structures.

See also: (14)

Less than 10 dwellings: **essential**/beneficial/not applicable

### Suggested evidence

#### Text

- Appraisal covering the topics Character (A3.2), Landscape, habitat and green infrastructure (A3.5) Built form, townscape, topography and views (A3.6),

#### Drawings

- Appraisal drawings as appropriate showing existing features including topography within and surrounding the site
- Concept diagram and/or illustrative or detailed layout (1:500-1:1250, including an area at least 150m out from the site) showing retained features
- Street sections and/or site sections showing finished floor and site levels (1:100-1:500)

## Guidance

Sections: [Appraisal: A3.2](#) | [A3.5](#) | [A3.6](#) | [Neighbourhoods: N2 \(all\)](#) | [N4 \(all\)](#) | [N6 \(all\)](#) | [Buildings: B1.1](#)

Code for Sustainable Homes: Ecological Value of Site Eco 1, Ecological Enhancement Eco 2, Protection of Ecological Features Eco 3, Change in Ecological Value of Site Eco 4

## Building for Life Sheet

# 8

### Does the scheme feel like a place with a distinctive character?

- Does the scheme have a clear design concept?
- Does the scheme help to maintain and extend the positive character and identity of the area?
- Is there a good balance between the individual identity of the scheme and the identity of the wider area?
- Is there enough variety to add interest within the scheme and avoid monotony but not too much that would make it too busy or fragmented?

Less than 10 dwellings: essential/**beneficial**/not applicable

#### Suggested evidence

##### Text

- Appraisal covering the topic Character (A3.2) and Built form, townscape, topography and views (A3.6)

##### Drawings

- Appraisal drawings as appropriate showing existing features including topography within and surrounding the site
- Concept diagram and/or illustrative or detailed layout (1:500-1:1250, including an area at least 150m out from the site) showing retained features
- Street sections and/or site sections showing finished floor and site levels (1:100-1:500)
- Building plans and elevations and/or street elevations (1:100-1:50)
- Typical details of streets, spaces and landscape planting (typically 1:50-1:100)



### Guidance

Section 3: [Appraisal: A3.2](#) | [A3.6](#) | [Neighbourhoods: N2 \(all\)](#) | [N4 \(all\)](#) | [N5](#) | [N5.1](#) | [N6 \(all\)](#) | [Streets: S1 \(all\)](#) | [Buildings: B1.2](#) | [B1.6](#) | [B2.1](#) | [B2.2](#) | [B3 \(all\)](#)

Section 4: [Technical requirements: 4B](#) | [4E](#) | [4G](#) | [4H](#) | [4I](#)

Manual for Streets: Section 4, 5

## Building for Life Sheet

# 9 Do the buildings and layout make it easy to find your way around?

- a. Does the design reinforce or create a hierarchy of streets with a clear difference between different orders of street (primary, secondary, tertiary etc.)?
- b. Do the scale, character and orientation of buildings work to embody and emphasize the hierarchy of streets?
- c. Are there sufficient connections to allow a choice of route (permeability)?
- d. Are views along streets long enough to see where you are going?
- e. Are there landmarks, gateways, community focal points and open spaces at appropriate places to help people find their way around?

Less than 10 dwellings: essential/beneficial/**not applicable**

### Suggested evidence

#### Drawings

- Concept diagram and/or illustrative or detailed layout (1:500-1:1250, including an area at least 150m out from the site) showing retained features, street hierarchy, public spaces, landscape features and landmarks and the arrangement and orientation of buildings (fronts and backs)
- Street sections (1:100-1:500)

## Guidance

Section 3: [Neighbourhoods: N2 \(all\) | N5 | N5.1 | N5.2 | N6 \(all\) | Streets: S1 \(all\) | S2.4 | Buildings: B1 | B1.2 | B1.3 | B1.4 | B2.4](#)  
Manual for Streets: Section 4, 5, 6.1-6.4

## Building for Life Sheet

# 10 Are streets defined by a well-structured building layout?

- a. Do buildings work together to form a continuous front (is there a definite building line and sense of enclosure)?
- b. Do buildings (doors and windows) front onto streets and are there appropriate front gardens and boundary treatments (are backs and sides facing public spaces avoided)?
- c. Is there a clear distinction between public and private spaces?
- d. Are buildings the right height for the width of the street to avoid streets that are either too open or too enclosed?

Less than 10 dwellings: **essential**/beneficial/not applicable

### Suggested evidence

#### Drawings

- Concept diagram and/or illustrative or detailed layout (1:500-1:1250, including an area at least 150m out from the site) showing street hierarchy and the arrangement and orientation of buildings (fronts and backs)
- Street sections (1:100-1:500)



## Guidance

Section 3: [Neighbourhoods: N2 \(all\) | N6 \(all\)](#) | [Streets: S1 \(all\) | S2.4](#) | [Buildings: B1 | B1.2 | B1.3 | B1.4 | B1.6 | B2.4](#)  
Manual for Streets: Section 5

## Building for Life Sheet

# 11

### Does the building layout take priority over the streets (highways) and car parking, so that the highways do not dominate?

- Does the proposal form part of or create a street as a place rather than just a thoroughfare?
- Are the buildings, gardens, parking and highways aligned and coordinated and do they work together to create an integrated environment?
- Does pedestrian (or shared) space form the main integrating feature shared by both buildings and highways?

# 12

### Is the car parking well integrated and situated so it supports the street scene?

- Is there adequate parking, including meeting Lifetime Homes standard and for wheelchair housing (what is the required and proposed parking ratio)?
- Is a range of parking solutions used to suit the specific situation?
- Is there adequate surveillance of parking?
- Do parked cars adversely dominate the design?
- Has street parking been successfully resolved?

Less than 10 dwellings: **essential**/beneficial/not applicable

#### Suggested evidence

##### Text

- Parking strategy and table of parking provision

##### Drawings

- Concept diagram and/or illustrative or detailed layout (1:500-1:1250) showing street hierarchy, the arrangement and orientation of buildings (fronts and backs) and locations for parking
- Street sections (1:100-1:500)

## Guidance

Section 3: [Neighbourhoods: N5](#) | [N5.5](#) | [Streets: S1 \(all\)](#) | [S2.4](#) | [S2.5](#) | [Buildings: B1](#) | [B1.2](#) | [B1.3](#) | [B1.4](#) | [B1.6](#) | [B2.4](#)

Section 4: [Technical requirements: 4B 1.1.14](#) | [4B 2.1.18](#)

Manual for Streets: Section 5, 6.1-6.4, 9

## Building for Life Sheet

# 13

## Are the streets pedestrian, cycle and vehicle friendly?

- Does the scheme consider the needs of disabled people first by adopting inclusive design standards throughout?
- Are the needs of all users balanced, reflecting the priority for inclusive design?
- Have appropriate measures been taken to manage vehicle speed with a minimum of features?
- Is there sufficient space for all users appropriate to the location and scale of development?
- Does the scheme provide for continuous access as far as possible?
- Is there adequate cycle parking?

Less than 10 dwellings: **essential**/beneficial/not applicable

### Suggested evidence

#### Text

- Parking strategy and table of cycle parking provision

#### Drawings

- Concept diagram and/or illustrative or detailed layout (1:500-1:1250) showing street hierarchy, cycle routes, locations for cycle parking and main walking routes
- Street sections (1:100-1:500)
- Typical details of open spaces, footways, speed reduction features, crossings and cycle parking (1:50-1:100)



## Guidance

Section 3: [Appraisal: A2](#) | [Neighbourhoods: N1 \(all\)](#) | [N5](#) | [N5.2](#) | [N5.4](#) | [Streets: S1 \(all\)](#)

Inclusive Mobility guidance: Sections 3, 4, 5 and 6

Lifetime Homes: Criteria 1, 2, 3, 4

If the scheme creates new streets see also

Section 3: [Streets: S2 \(all\)](#)

Section 4: [Technical requirements: 4B.1.1](#) | [4B.1.2](#) | [4B.2.2](#) | [4B.3.2](#) | [4B.4](#)

Manual for Streets: Section 6, 7

## Building for Life Sheet

# 14

## Does the scheme integrate with existing streets, paths and development?

- Does the scheme present an appropriate face to abutting development (front-to-front and back-to-back, scale, character etc.)?
- Do the proposed access points and routes create the most direct connections to main routes and destinations, in particular centres, public transport, schools and employment?
- Are there sufficient connections to existing routes for the size of the site?
- Do the access arrangements allow for choice of route?
- Do the access arrangements accommodate all pedestrians? If that is not practicable, are acceptable alternatives available.
- Are the routes for pedestrians and cyclists to main destinations as direct as possible?

See also: (6, 9)

Less than 10 dwellings: **essential**/beneficial/not applicable

### Suggested evidence

#### Text

- Appraisal covering the topic Character (A3.2), Built form, townscape, topography and views (A3.6) and Access, transport and street patterns (A3.4)

#### Drawings

- Appraisal drawings as appropriate showing existing street pattern and hierarchy, orientation of buildings (fronts and backs) and character areas
- Concept diagram and/or illustrative or detailed layout (1:500-1:1250, including an area at least 150m out from the site) showing street hierarchy, access points, the arrangement and orientation of buildings (fronts and backs)
- Street sections and/or site sections showing finished floor and site levels (1:100-1:500)
- Building plans and elevations and/or street elevations (1:100-1:50)
- Typical details of streets, spaces and landscape planting (typically 1:50-1:100)

## Guidance

Section 3: **Appraisal:** A3.2 | A3.4 | A3.6 | **Neighbourhoods:** N5 | N5.1 | N5.1 | N5.6 | N5.7 | **Buildings:** B1.2 | B3

Section 4: **Technical requirements:** 4B

Manual for Streets: Section 4, 5

## Building for Life Sheet

# 15

### Are public spaces and pedestrian routes overlooked and do they feel safe?

- a. Are there enough buildings addressing the street or space?
- b. Do windows and doors face onto public highways, rights of way and shared private space, including parking areas (avoiding blank or inactive frontages)?
- c. Is access to the back gardens or spaces of properties secure and safe?
- d. Are routes and spaces well connected, safe and convenient for all to use to keep them busy?
- e. Is there adequate street lighting?
- f. Has the scheme been checked against the Safer Places and/or Secured by Design checklists?

Less than 10 dwellings: **essential**/beneficial/not applicable

#### Suggested evidence

##### Text

- Completed Safer places checklist and/or Secured by Design assessment (optional)

##### Drawings

- Concept diagram and/or illustrative or detailed layout (1:500-1:1250) showing street hierarchy, the arrangement and orientation of buildings (fronts and backs) and locations for parking
- Street sections (1:100-1:500)
- Building plans and elevations and/or street elevations (1:50-1:100)



#### Guidance

Section 3: [Neighbourhoods: N5](#) | [N5.2](#) | [Streets: S1 \(all\)](#) | [Buildings: B2.4](#)

Manual for Streets: Section 4.6, 5.6

Safer Places: The planning system and crime prevention, Annex 4

Secured by Design New Homes current edition

## Building for Life Sheet

# 16

### Is public space well designed and does it have suitable management arrangements in place?

- Do all parts of the public realm, in particular open and green spaces, have a definite purpose and form a positive part of the scheme as a whole?
- Have suitable organisations been identified to take responsibility for the management and maintenance of all parts of the scheme outside individual properties?
- Are public and semi-public spaces accessible to all, uncluttered and allow for flexibility?
- Does the scheme include adequate and appropriate planting?
- Are surface materials and street furniture simple, coordinated and made of robust, high quality materials?

Less than 10 dwellings: essential/**beneficial**/not applicable

#### Suggested evidence

##### Text

- Appraisal covering the topic Character (A3.2) and Landscape, habitat and green infrastructure (A3.5)
- Landscape design strategy
- Statement of management arrangements

##### Drawings

- Appraisal drawings as appropriate showing existing features including topography within and surrounding the site
- Concept diagram and/or illustrative or detailed layout (1:500-1:1250, including an area at least 150m out from the site) showing hard and soft landscape treatments
- Street sections (1:100-1:500) showing hard and soft landscape treatments
- Typical details of streets, spaces and landscape planting, to include street lighting, street furniture and signage (typically 1:50-1:100)

## Guidance

Section 3: **Appraisal:** A3.2 | A3.5 | **Neighbourhoods:** N2 (all) | N4 (all) | N5 | N5.1 | N6 (all) | **Streets:** S1 (all) | **Buildings:** B1.2 | B2.1 | B2.2 | B3 (all)

Section 4: **Technical requirements:** 4B | 4C | 4E | 4G | 4H | 4I  
Manual for Streets: Section 5.10-5.13, 9, 10, 11

Code for Sustainable Homes: Ecological Value of Site Eco 1, Ecological Enhancement Eco 2, Protection of Ecological Features Eco 3, Change in Ecological Value of Site Eco 4

## Building for Life Sheet

# 17 Do buildings exhibit architectural quality?

- a. Are the buildings fit for purpose and do they adequately express their purpose?
- b. Does the design provide visual richness in form and detail proportionate to the size of the building as a whole?
- c. Does the design have a sense of consistency and order, avoiding clutter, monotony and arbitrary or out of scale details?
- d. Is there a purpose to variety and variation such as to respond to focal points, gateways, corners or pinch-points or to incorporate features that improve the energy and resource performance of the building?

Less than 10 dwellings: **essential**/beneficial/not applicable

### Suggested evidence

#### Text

- Appraisal covering the topic Character (A3.2) and Built form, townscape, topography and views (A3.6)

#### Drawings

- Illustrative material showing the characteristics and details of local buildings that can serve as a design resource.
- Concept diagram and/or illustrative or detailed layout (1:500-1:1250, including an area at least 150m out from the site) showing the arrangement of building types
- Street sections (1:100-1:500)
- Building plans and elevations and/or street elevations (1:50-1:100)
- Typical building details (1:10-1:50)

## Guidance

Section 3: **Appraisal: A3.2** | **A3.6** | **Buildings: B2 (all)** | **B3 (all)**

## Building for Life Sheet

# 18 Do internal spaces and layout allow for adaptation, conversion and extension?

- a. Do plots have sufficient space to allow for extensions?
- b. Does the method of construction allow for easy alteration?
- c. Does the development achieve the Lifetime Homes Standard and provide a percentage of wheelchair housing?
- d. Does the scheme meet minimum space standards?

See also: (5)

Less than 10 dwellings: essential/**beneficial**/not applicable

### Suggested evidence

#### Text

- Tables of areas and dimensions (where required by policy, demonstrating all Lifetime Homes and wheelchair housing criteria are met)

#### Drawings

- Detailed layout (1:500) (where required, showing location of Lifetime Homes and wheelchair housing)
- Building plans and elevations (1:50-1:100) (where required, showing Lifetime homes and wheelchair housing features)

## Guidance



Section 3: **Buildings: B2.1 | B2.2 | B3.2**

Section 4: **Technical requirements: 4A**

## Building for Life Sheet

**19** Has the scheme made use of advances in construction or technology that enhances its performance, quality and attractiveness?

**20** Do buildings or spaces outperform statutory minima such as building regulations?

See also: (5, 18)

<10 dwellings: essential/**beneficial**/not applicable

### Suggested evidence

#### Text

- Sustainability Statement
- Code for Sustainable Homes design stage assessment results

#### Drawings

- Detailed layout (1:500)
- Building plans and elevations (1:50-1:100)
- Typical building details (1:10-1:50)

### Guidance

Section 3: **Buildings: B2.3 | B3** |

Section 4: **Technical requirements: 4A**

Code for Sustainable Homes Technical Guide



# The design guidelines

# 3

This section sets out the specific **design guidelines** that are essential to follow in order to meet the Building for Life criteria.

*Bold text in boxes are the main design guidelines. They are general statements of what is required of designs if they are to meet the Building for Life criteria. Each main design rule has a letter and number designation. The letter corresponds to the main sub-sections of Part 3.*

- **A:** Assessment and Appraisal
- **N:** Neighbourhoods
- **S:** Streets
- **B:** Plots, blocks and buildings

*To the side of each main design guideline is a list of the relevant Building for Life criteria.*



*Coloured tabs indicate the section and numbers identify the guidelines contained on the page.*

*Bold text is an elaboration or further specific indication of what is required by the main guideline.*

*Italic text provides a reasoned justification or an explanation of the guideline.*

*Section 3.1 includes sheets providing more information on what is necessary for an adequate appraisal of the site.*



*The sheets also include examples of an appraisal, suggesting how they might be illustrated.*



# 3.1

## Assessment, inclusion and appraisal

## 3.1 Assessment, inclusion and appraisal

### Aims and core principles

The overall aim of this guide is to help create high quality residential environments. What is a high quality residential environment? At the very least, it should meet the standards we expect of anything we make. In most cases, we expect it to:

- Do what it claims to do
- Suit our purposes and work well
- Be well made, last and not break down too frequently
- Look good and be a pleasure to use.

Quality is not just about the way things look. It is just as much about how well they work and fit in with the way we live.

This is particularly true of residential environments. They are much more than a product. They are part of the fabric of our communities. Residential environments are intended for the use of **many** people. The streets of a neighbourhood are **public highways**, legally for the use of us all.

Each residential environment is a smaller part of the larger environment of a village, town or city. In order to work properly, a residential area has to **physically connect** with other areas.

The expectation in South Yorkshire is therefore that residential environments should not only meet these expectations but should also be:

- **Integrated** and fit physically into their context
- **vital**, active and well managed
- **equitable**, cohesive, inclusive, safe and secure
- **local**, distinctive and attractive
- **efficient**, flexible and adaptable.

Together, these are the characteristics of sustainable development.

These core principles are set out in more detail in [Appendix A1](#).

## A1 Building for Life

In order to achieve high quality residential environments, all new development of ten or more dwellings in South Yorkshire will be required to achieve a score of at least Good (Silver) in a Building for Life assessment (a score of 14 or 15 out of 20).

- Where the Local planning authority has the appropriate adopted policies in place, new development will need to meet Lifetime Homes standards and Code Level 3 or better of the Code for Sustainable Homes or as specifically indicated by the policy. Notwithstanding any policy requirements, these standards will be used to inform Building for Life assessments.
- Developments of less than ten dwellings are still expected to meet the criteria and follow the design principles set out in this guide. Not all of the criteria and principles will be relevant to smaller schemes. The principal difference is that schemes of less than ten dwellings will not be taken through the full formal assessment and proportionally less material will need to be submitted.

*See Section 2 for more information on Building for Life and the assessment criteria and process.*

## A2 The needs and range of users: inclusive design

All new development must take account of the needs of the full range of users.

*A fundamental starting point in design is to acknowledge that people's needs are not all the same. Different people have different needs and any one person has different needs at different stages in life.*

*In addition to age, needs vary with gender, disability, culture and physical and mental ability amongst other things. Taking the wider perspective of sustainability, users also include the wider community, wildlife and future generations.*

- Potential users thus include:
  - Disabled people
  - People from different cultural backgrounds
  - Parents/carers and infants, children, teens, adults, the elderly
  - People on foot
  - People with pushchairs or trolleys
  - People in wheelchairs and mobility scooters
  - Dog walkers
  - People on bicycles and motorcycles, in cars, vans, and other vehicles
  - People in the wider community
  - People in future generations
  - Wildlife.

*Taking into account the full range of users is to take an inclusive approach to design. A commitment to inclusive design should be made from the outset and should continue through the life of the project.*

*An Access Champion should be appointed from the beginning as part of the design team to coordinate and see through the application of inclusive design principles and standards. Ideally the Access Champion should be a consultant member of the National Register of Access Consultants or equivalent. For more information see: <http://www.nrac.org.uk>.*

*Guidance on the coverage of inclusive design in the access component of Design and Access Statements is given in CABE's Design and access statements - How to write, read and use them and each authority's own guidance. A statement should be submitted at each stage of the process to describe the access issues and explain how an inclusive design has been achieved.*

- Highway and planning authorities must comply with the Disability Equality Duty under the Disability Discrimination Act 2005. This means that in their decisions and actions, authorities are required to have due regard to the following principles:
  - promote equality of opportunity between disabled persons and other persons
  - eliminate discrimination that is unlawful under the 2005 Act
  - eliminate harassment of disabled persons that is related to their disabilities
  - promote positive attitudes towards disabled persons
  - encourage participation by disabled persons in public life
  - take steps to take account of disabled persons' disabilities, even where that involves treating disabled persons more favourably than other persons.



*Neighbourhoods and streets need to cater for a wide range of users with a wide range of needs*

## A2.1 Inclusive design

The concept of inclusive design should be based on five overarching principles.

### **Inclusive**

*Assist everyone, regardless of age, gender, cultural background or disability, to make full use of the built environment. Dwellings, public buildings and spaces should meet a diverse range of needs over time.*

### **Accessible**

*Give convenient and independent access into and around neighbourhoods, streets, homes and other buildings (and the services in them) to the widest range of people, including those with physical and/or sensory impairments, older people and children.*

### **Flexible and Adaptable**

*Create streets, buildings and products that can be used in different ways and adapted by simple means to meet people's changing needs over time or to suit the needs of different users.*

### **Sustainable**

*Combine the benefits of quality, accessibility, flexibility and adaptability to create neighbourhoods that meet current and future needs and to sustain long term desirability and demand.*

### **Good Value**

*Use simple designs for homes to accommodate future provision from the outset to ensure any subsequent adaptations are cost-effective and less expensive for the people who live in them.*

## A2.2 Lifetime neighbourhoods

Adherence to the principles in this guide should help to create 'Lifetime Neighbourhoods' that offer everyone the best possible chance of health, well-being, economic and social engagement regardless of their age, circumstances, health or disability.

- Lifetime Neighbourhood are created through:
  - Making a range of neighbourhood facilities and services easily accessible from peoples' homes by continuous, safe, and convenient pedestrian movement networks
  - Creating an inclusive public realm
  - Providing adequate parking for disabled residents and visitors, and to serve facilities and services
  - Developing inclusive homes such as those that meet the Lifetime Homes and wheelchair housing standards.

*Lifetime Neighbourhoods work well for children and families as well as older and disabled people and they do not exclude people as their circumstances change or as they age and become more frail or disabled. This means that there is a particular emphasis on designers and developers clearly showing that they:*

- *design for people and understand the present and future needs of all the likely residents and visitors*
- *consult and involve user groups and stakeholders*
- *design buildings and built environments that are inclusively accessible to all, flexible and adaptable in use.*

*See Section 3.2, Neighbourhoods, N1 to N6, for more detail.*

## A2.3 Inclusive public realm

**All streets and public spaces must provide the highest achievable standard of inclusive access for all members of the community**

- The following elements and features are vitally important to the safety and inclusion of disabled people, children and other pedestrians:
  - An integrated network of continuous safe and convenient pedestrian routes accessible to all between homes and neighbourhood facilities and services
  - The effective separation of pedestrians from cyclists and other vehicles by a reliably detectable kerb upstand or equivalent in all locations. An exception is level surface streets (see S1.4), which are acceptable only where vehicle flows are very low and subject to agreement with the Local Authority
  - Frequent, safe and inclusive crossing points with flush kerbs and tactile paving
  - Footway build-outs with dropped kerbs and tactile paving to enable pedestrians crossing the road to see past parked vehicles
  - Effective means of way-finding for blind and partially sighted people
  - Distinctive features that are easy to recognise so that people can find their way around and easily distinguishable entrances to buildings
  - Street furniture selected to meet inclusive designs standards and located to leave a clear route for pedestrians and not create a hazard
  - Resting places with, inclusive seating and spaces for wheelchair and scooter users.

*See Section 3.3, Streets, S1 to S2 and Section 4B for more detail.*

## A2.4 Inclusive buildings

Where required by planning policy, dwellings should meet the requirements of Lifetime Homes and the wheelchair housing standards.

Non-residential buildings and their approaches accommodating neighbourhood local services and facilities should adopt the highest standard of inclusive design.

- In addition to the design criteria set out for Lifetime Homes, the following elements are equally important to the safety and inclusion of disabled people, the elderly and children:
  - Accessible parking within the development and to service public facilities, including in otherwise car free developments. These should be located as close as possible to the building entrance
  - Lift access to flats above and below entrance level, including from basement and undercroft parking where provided
  - The designated 'entrance level' of dwellings being the storey containing the main entrance door
  - Adequate space to accommodate through-floor lifts without losing the use of a bedroom
  - Washbasins that can be used from the toilet
  - The difficulties created by integral garages and the importance of living accommodation being provided on the same level as the main entrance need to be recognised in any proposals
  - Adoption of as many as possible of the good practice recommendations set out in the Lifetime Homes design criteria is recommended
- Housing designated as homes for disabled or older people must be fully accessible to wheelchair users in accordance with the requirements and recommendations of the 'Wheelchair Housing Design Guide' by Stephen Thorpe and Habinteg Housing Association. Housing which is readily adaptable for residents who are wheelchair users should meet the basic standards of wheelchair accessibility based on the guide so that it is suitable for fitting out to accommodate wheelchair users when required
- 'Extra Care' and similar supported housing should aim to provide a 'home for life' to minimise the likelihood of residents needing to move into less independent accommodation as they grow older
- Non-residential buildings should meet the standards set out in BS 8300:2009 *Design of Buildings and their Approaches to meet the Needs of Disabled People – Code of practice*, the standards for specific building and service types it refers to, and the inclusive design standards developed by each authority in liaison with disabled people.

See Section 3.4, Buildings, B1 to B3 and Section 4A, Space standards for more detail.

## A2.5 Safer places

Safety and security are important parts of creating a more inclusive environment. The two documents *Safer Places: the planning system and crime prevention* and *Secured by Design New Homes* guidelines are useful companions to this guide.

- Key principles of safer places include the following:
  - Create active streets that connect place people want to go (see N1 and N5)
  - Keep different street users in the same street space (avoid visually segregated single-use paths) (see N5 and S2)
  - Create layouts that are easy for people to find their way around (see N5, S2 and B1)
  - Create active frontages and well enclosed streets (see N5, S1 and B1)
  - Clearly define public and private spaces (see N5, S1 and B1)
  - Provide adequate physical protection of private spaces (see S1 and B1)
  - Ensure streets and spaces are adequately lit (see S2.8 and 4E).
  - Ensure designs account for the needs of people from different cultural backgrounds

## A3 Appraisal

All proposals must be based on a thorough appraisal of the site and the surrounding area in which development is proposed. This follows from the Guidance on information and requirements for validation (DCLG March 2010) with respect to Design and Access Statements. The scope of the appraisal should be agreed with a development management officer. The information required should be commensurate with the scale of development subject discussion with the local planning authority. The material produced for the appraisal as set out below is intended to fulfil the appraisal requirements for the Design and Access Statement. It is not intended as an additional requirement but an indication of what should be included.

- An essential prerequisite to successful design is an appraisal of the site and locality with direct reference to an initial vision and core aims and principles.

*'A design and access statement should demonstrate the steps taken to appraise the context of the proposed development. It is important that an applicant should understand the context in which their proposal will sit, and use this understanding to draw up the application.'* paragraph 144, Guidance on information requirements and validation (DCLG March 2010).

*The guidance in the first part of this section sets out the essentials for completing the appraisal and concept stages in the design process and working to achieve the fundamental task of fitting new development into its locality.*

*This early stage is essential for achieving all the core principles but most particularly the aim of creating development that is integrated and local. In many ways, this set of principles is a precursor or prerequisite for achieving the others.*

*The importance of site and locality appraisal at the early stages in the process cannot be emphasised enough. If new development is to have a defined role and work together with the wider area, it is impossible to do so without knowing what is in the area and how it works.*

*For an appraisal to be effective, it must be driven and guided, on the one hand, by an initial vision of what might be possible and, on the other, by the aims, objectives and principles to be achieved.*

**To be considered sufficient, an appraisal should cover the following topics:**

- **A3.1 Neighbourhood and Housing:** including the location and type of nearby centres, distribution and proximity of land uses, facilities and services as well as the range of housing type and tenures to enable a mixed and balanced community to thrive in the neighbourhood.
- **A3.2 Character:** including diversity and quality, character areas, street pattern and layout, orientation to topography, density, scale, building types, local vernacular and historic features.
- **A3.3 Renewable energy, carbon dioxide and other local resources:** including base resources of solar and wind, microclimate, local renewable energy sources, measures to reduce carbon emissions, managing and adapting to climate change as well as utilities infrastructure, waste recycling and collection regimes.
- **A3.4 Landscape, habitat and green infrastructure:** including elements of landscape character, surface water drainage, vegetation, habitat, biodiversity, and public open space.
- **A3.5 Access, transport and street patterns:** including pedestrian, cycle, public transport and vehicular; accessibility, permeability, hierarchy of routes and relation to centres, uses and topography.
- **A3.6, Built form, townscape, topography and views:** including response to topography, legibility, landmarks, network of focal points and open spaces, perceptual features and views.
- **A3.7 Technical constraints:** including flooding, ground conditions, slopes, infrastructure wayleaves, noise and other nuisances, designations and covenants and any others as may apply.

*The aim of the appraisal is to identify the assets and opportunities, constraints and deficiencies of the site and the area in which it sits. The different aspects are not listed in order of importance or the sequence of analysis.*

- The length and complexity of the appraisal should be proportionate to the size and complexity of the site and surrounding area. The appraisal does not need to be long but should be accurate.

*For small sites, particularly on schemes of less than ten dwellings the appraisal will be checked against the following questions.*

- *What neighbourhood is the development part of?*
- *Where is the centre?*
- *Where are the key facilities such as schools, shopping, health care?*
- *What is the character of development in the area?*
- *Are there any obvious sources of renewable energy?*
- *What kind of streets serves the site?*
- *Is there any public transport nearby?*
- *Where are the points of access to the site?*
- *Are there trees, plants or habitat within and around the site?*
- *What is the arrangement of buildings within and around the site?*
- *Are there historic buildings in or around the site?*
- *What is the topography like and are there views in or out?*
- *Are there any technical constraints on the site?*

### A3.1 Neighbourhood and housing

The neighbourhood and housing component of the appraisal should be carried out through a combination of desktop searches, enquiries and visits to the site and surroundings. A large amount of relevant information is available on the Internet and so can be compiled relatively easily. Other sources include the Local Authority, Town or Parish Councils, NHS Trust and Local Education Authority.

The appraisal should cover the topics set out in this section:

- Centres (N1)
- Facilities and services (N1.1)
- Accessibility (N1.2)
- Position within the settlement (central, suburban, rural) (N1.3)
- Community focal points (N1.4)
- Predominant existing housing types, demand and need for affordable housing (type and tenure), including the needs of particular groups such as the elderly and disabled.

The output of the appraisal is most effective as a plan showing the location of the site and its position within the settlement, the location of centres, facilities and focal points and a table of distances to those facilities. The scale of the plan should be as large as possible while still showing both the site and the centres that serve it. Ideally the distances should be stated as actual travel distances (rather than straight line) and take account of factors such as slopes as identified in Section N1.2).

The appraisal should be set out in a report or statement. One of the principal source of information for the report will be the Local Housing Needs Assessment and Strategic Housing Market Assessment as produced by the Local Authority.

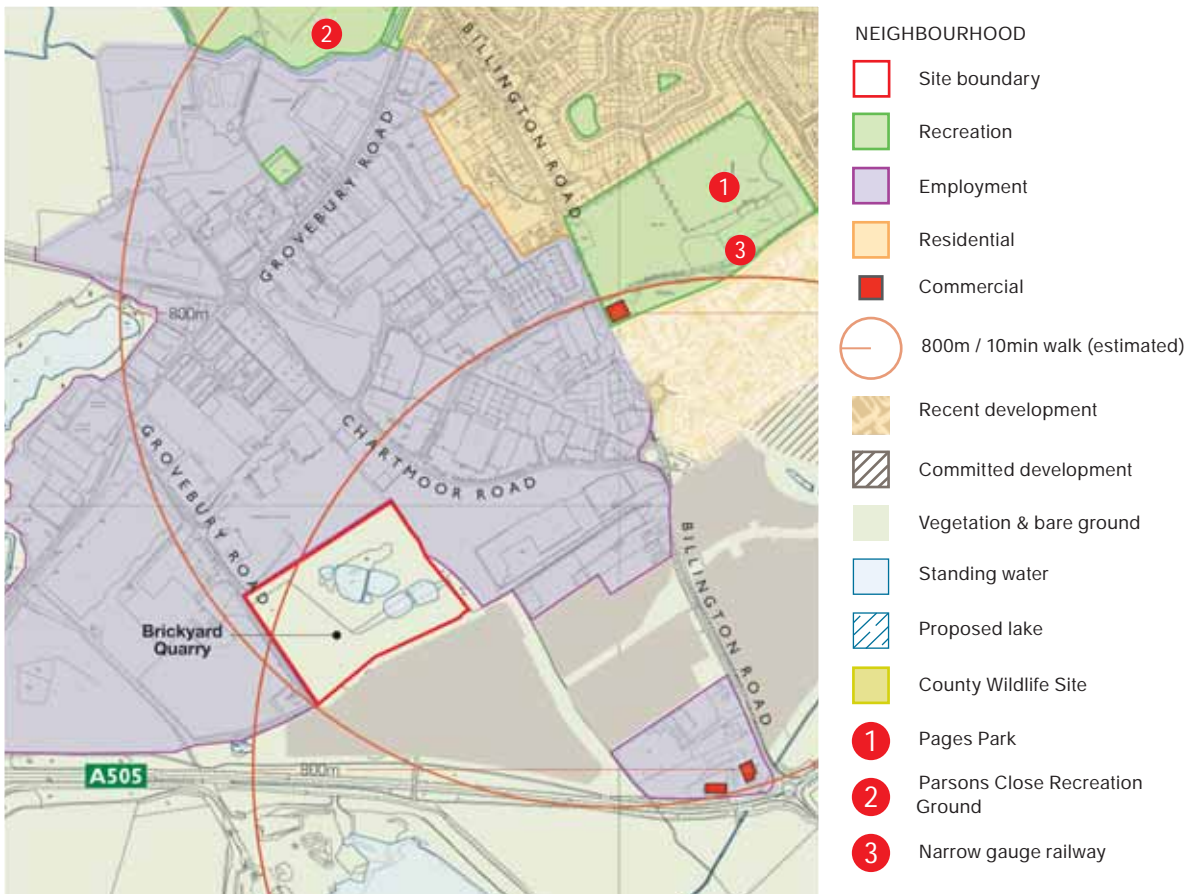

A neighbourhood appraisal drawing showing surrounding land uses and facilities.

Mapping © Crown copyright. All rights reserved Licence Number 100018816, 2010

## A3.2 Character

The character element of the appraisal should combine a desktop analysis of plans and other documents and site surveys. It builds on the appraisal of movement (A3.4) and townscape (A3.6) and they can helpfully be done together. Similarly, there is some overlap with the landscape appraisal (A3.5).

The appraisal area should extend to at least 400 square metres or 150 metres out from the boundary of the site. Appraisals for very large sites may need to cover a wider area. A characteristic sample of one or two streets may be used to represent a larger area of uniform character as identified in the desktop study.

The starting point for the appraisal should be existing character assessments including the national landscape character areas produced by Natural England, the South Yorkshire Historic Environment Characterisation (SYHEC) and any city or borough-wide landscape character assessments.

The output of the study should be a map of character areas with definite boundaries following physical features along with a text description for each area. The descriptions should include key features at different scales, identifying types and patterns of:

- Streets
- Blocks and plot series
- Plots
- Buildings
- Details and materials.

Further aspects include: orientation to topography, density, scale, building types, local vernacular and historic features.

South Yorkshire Historic Environment Characterisation (SYHEC) <http://www.sytimescapes.org.uk/home>

Natural England national landscape character areas, <http://www.naturalengland.org.uk/ourwork/landscape/englands/character/default.aspx>

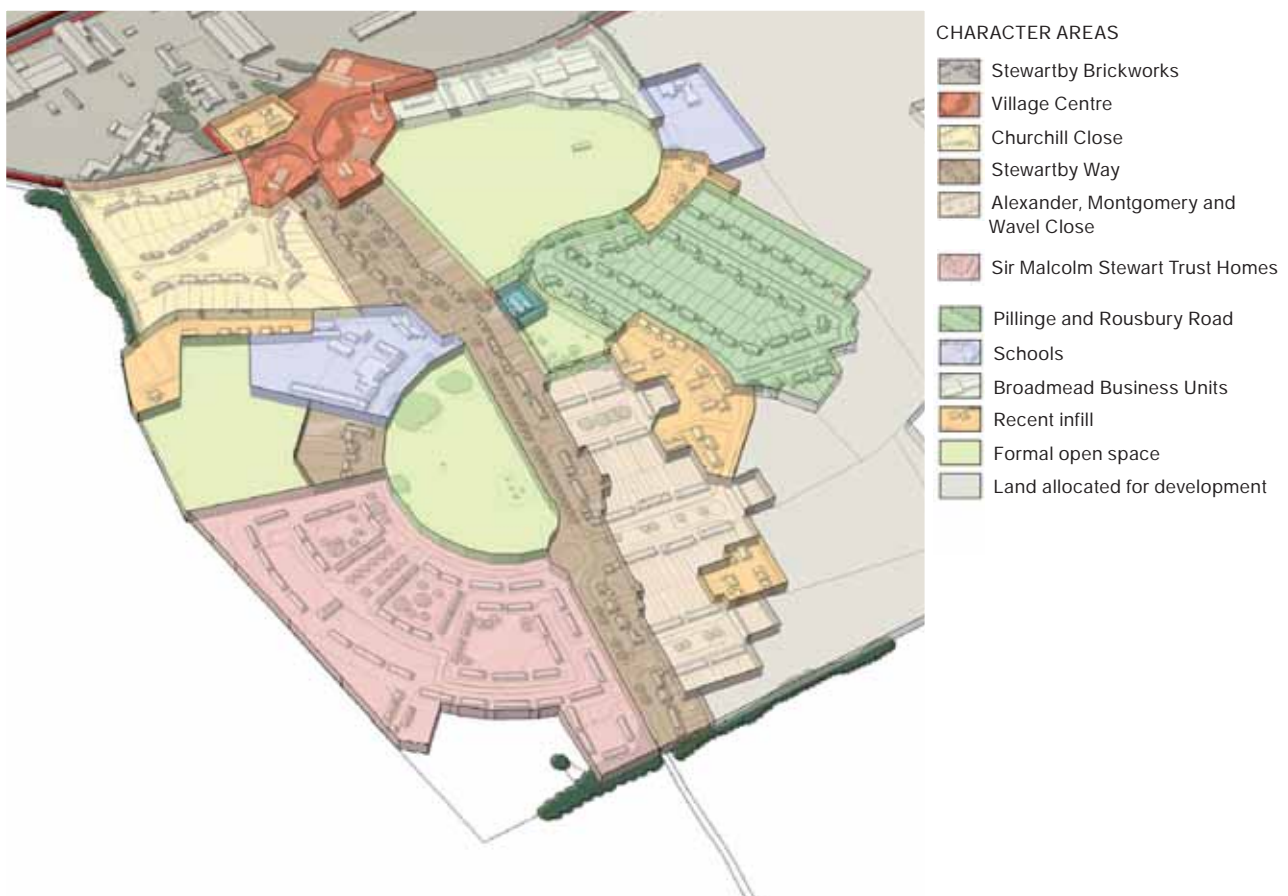

*Bird's eye view illustrating character areas.*  
 Mapping © Crown copyright. All rights reserved Licence Number 100018816, 2010

### A3.3 Renewable energy, carbon dioxide and other local resources

This part of appraisal should identify and assess the scope for improving energy efficiency, the viability of locally available sources of renewable and low carbon energy and any other measures to reduce carbon emissions. The appraisal should answer the questions, what can be done to reduce energy and resource demand through design and efficiency, which sources are most plentiful locally and which is the most efficient and cost effective to use on the site? A significant consideration in making an assessment of viability is the contribution that can be made by the Feed-In Tariff and Renewable Heat Incentive schemes. Refer to the Department of Energy and Climate Change for details.

The appraisal should set out the direction and speed of the prevailing wind and the regime of sun and shadow across the site in mid-winter, the equinox and mid-summer.

Information on wind speeds is available from the Department for Energy and Climate Change.

Key considerations for an assessment of alternative energy sources include:

- Ground conditions and sufficient space to accommodate ground loops for ground source heat
- Availability of locally sourced wood fuel for biomass heating
- Proximity of large heat users such as public buildings, leisure centres and schools to provide sufficient base load for biomass district heating
- Appropriate locations for siting of plant and delivery of fuel for district biomass.

Enquires must be made at the appraisal stage to determine if there is sufficient capacity in the utilities networks to support the proposed development to the

extent not provided by renewable, low carbon or other alternatives.

The appraisal will also need to determine the combined effects on local microclimate of:

- Solar orientation and exposure (sun/shade study)
- Prevailing winds
- Topography and distribution of buildings.

Where are the locations on the site that would be most comfortable for outdoor amenity space and activity? What mitigation is needed to improve the microclimate?

The requirements of the waste collection and recycling scheme operating and the implications for masterplanning and space requirements must be identified.

The output of the appraisal should be a Sustainability/ Energy Statement that sets out:

- End uses and predicted demand, including measures to reduce demand and increase efficiency
- An assessment of local and/or renewable resources by type and the contribution of the proposed sources as a percentage of demand
- The equipment and elements of design needed to realise the use of local sources
- Contribution to viability made by the Feed-In Tariff (Generation and Export) and Renewable Heat Incentive (refer to the Department of Energy and Climate Change for details)
- Necessary external inputs (mains utilities) as a percentage of demand
- Predicted reduction in carbon dioxide and any further use of 'waste' outputs.

A plan should also be included illustrating the sun-shade regime and direction of prevailing wind.

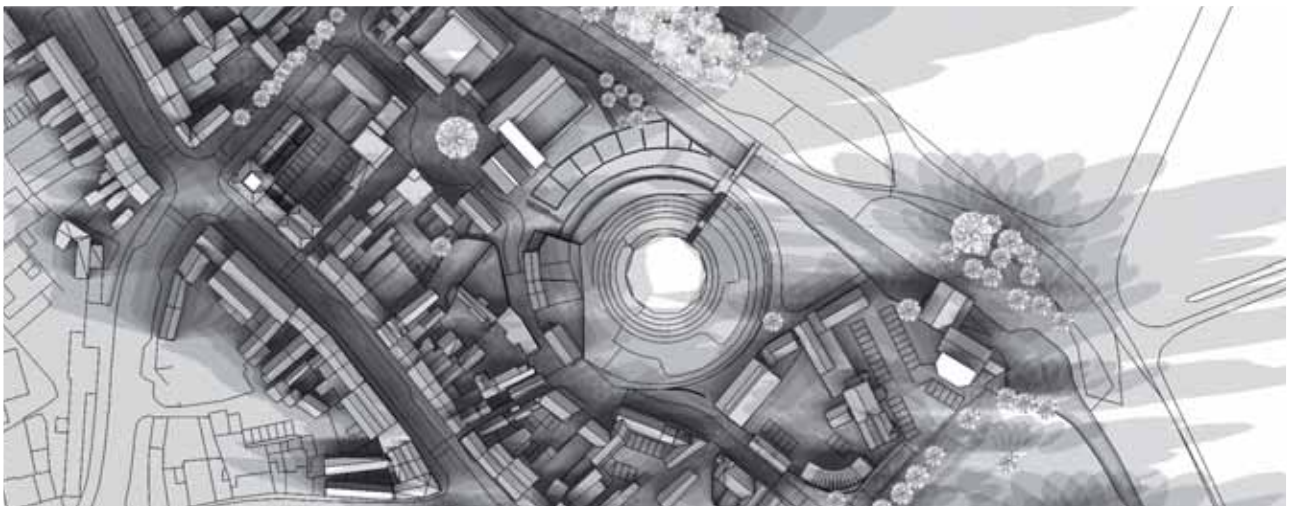

*A sun-shade analysis diagram created with a simple 3D drawing package, combining shadows at hourly intervals.*

*Mapping © Crown copyright. All rights reserved Licence Number 100018816, 2010*

### A3.4 Landscape, habitat and green infrastructure

The appraisal should identify the existing green infrastructure and key natural features both in the surrounding area and within the site. The extent to which the features are connected to a wider network should also be noted. Key elements that must be included in the appraisal include:

- Existing drainage features and the space requirements for surface water attenuation
- Existing areas and features of ecological value and the size of the areas necessary to maintain their value
- Existing trees and other vegetation
- Current use of existing open or green spaces including access points and lines of movement
- Space requirements for natural green space, formal and informal public open space as well as trees
- Identification of the body or bodies who will adopt and maintain the green features/open space and ensure that a suitable management regime can be put in place.

The appraisal needs to look at features within the site, immediately adjacent to the site and in the wider area.

The landscape element of the appraisal can make use of material from the character appraisal (A3.2), in particular reference to existing landscape character appraisals, as well as the technical appraisal (A3.7) with respect to flooding, ground conditions and drainage.

If there are trees on the site, a tree survey should be undertaken, with reference to BS 5837:2005.

Microclimatic conditions within the site should be noted with respect to the suitability of plant species to the conditions. Reference can be made to the local resource appraisal examination of sun-shade regimes and wind direction (A3.3).

The output of the appraisal should be a plan identifying the location of existing features and annotations or a report setting out an assessment of the value of the features, whether they are to be retained or not and any constraints involved with retention.



This diagram shows the main landscape features in the area surrounding a development site

## A3.5 Access, transport and street patterns

The appraisal of access, transport and street patterns needs to look at the site and surroundings at three broad levels for all modes of movement.

- 1. The wider network:** What are the main routes from the site to surrounding centres and community focal points? Where are the public transport routes and what is the level of service? Can accessibility standards be met (See N1.2)? This part of the appraisal is best done in conjunction with the neighbourhood appraisal (A3.1), which identifies the location of centres, facilities and services.
- 2. The local area:** What is the street hierarchy around the site? Which are the primary, secondary and lower order streets? Are the streets thoroughfares, loops or cul-de-sacs? This part of the appraisal is usefully done along with the character appraisal (A3.2) because of the contribution that street hierarchy makes to character.

- 3. The site:** Where are the potential access points? To which street or streets does the site connect? What level in the hierarchy is each street with an access point? What through connections can be made to extend the network? What position will any new route have within the hierarchy?

The output of the movement appraisal should include plans illustrating all existing routes and rights of way within 150 metres of the site, main destinations (or routes to them), the street hierarchy, public transport routes and stops. The plan should also note any barriers or impediments to movement including heavily used routes, restrictions and topography.

At all levels the appraisal needs to take into account the aim of achieving inclusive design.

The appraisal should also include a table of travel distances to principal destinations such as schools, shopping and local employment.

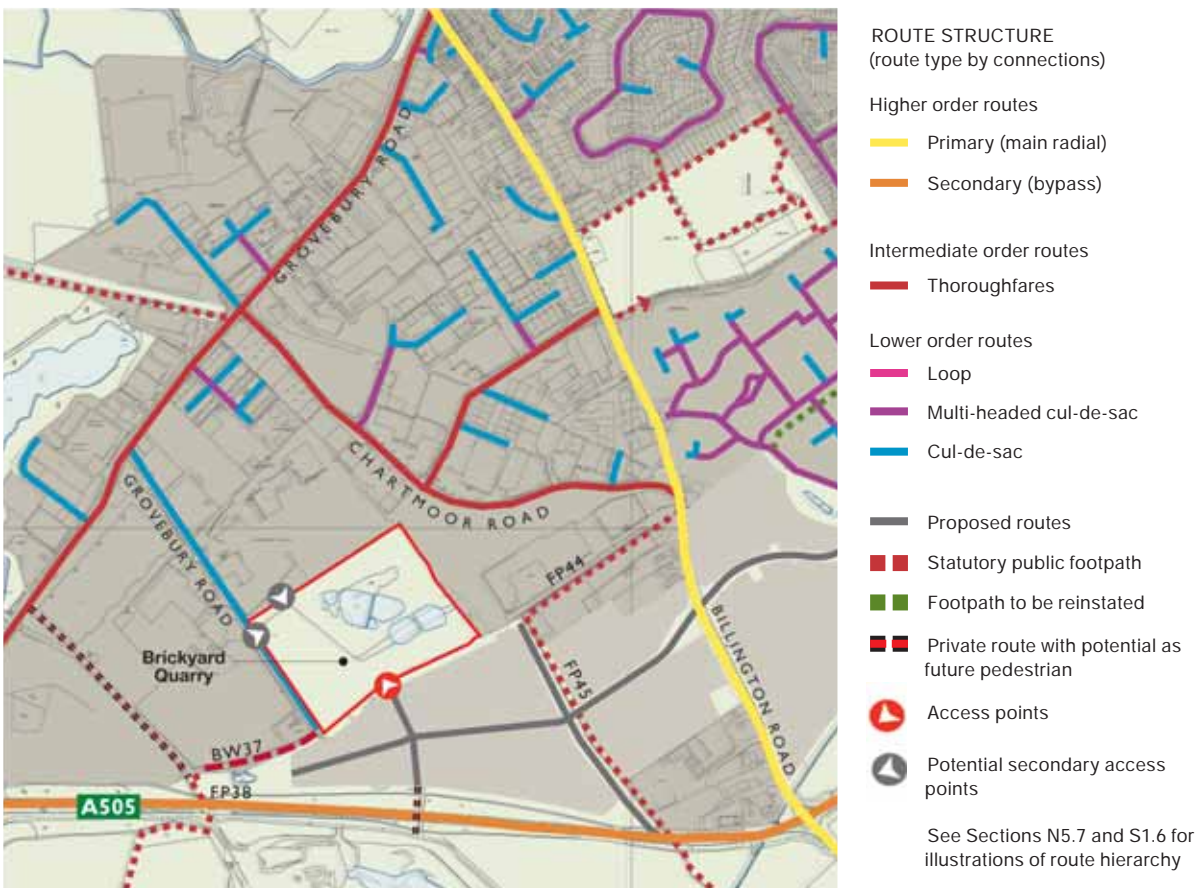

A diagram showing the existing pattern and type of routes in the area around a proposed development site.

Mapping © Crown copyright. All rights reserved Licence Number 100018816, 2010

### A3.6 Built form, townscape, topography and views

The main purpose of the appraisal of built form is to identify specific features visible from the street that make a place memorable and give it its identity. It is also essential to identify heritage assets and their significance. The built form appraisal needs to examine the townscape at the level of both the neighbourhood and the site. The main townscape elements are set out in (N6).

At the level of the neighbourhood, the appraisal needs to identify the features to which the proposed development might connect physically or visually. Are there local landmarks visible from the site? Are there routes through or past the site that lead to a focal point? Is the area legible? Similarly, are there adjacent elements that might be extended such as edges or skylines? Can development of the site extend a positive experience of enclosure or help overcome a negative sense of exposure?

An essential part of the built form appraisal at the neighbourhood level is to identify the orientation of plots and buildings surrounding the site. Which way do buildings face (front or back) on the immediately adjacent land and streets?

At the level of the site, the appraisal should identify any features within the site that could serve as a townscape

element. It also needs to identify key views both to and from the site.

Key existing features within a site that might make a significant contribution to instilling a strong sense of local identity include:

- Topography (alignment/ views)
- Routes (including tracks and footpaths)
- Natural drainage features
- Boundaries
- Trees and other vegetation
- Buildings.

The output of the built form appraisal should include plans locating the key townscape elements, heritage assets, views, fronts and backs adjacent to the site and spatial enclosure on adjacent streets. The plan should show the area within 150 metres of the site and extend as necessary to include main local landmarks.

As necessary, a statement on the significance of heritage assets near or within the site should also be included.

The character appraisal builds on the movement appraisal (A3.4) and built form appraisal (A3.6) and can helpfully be done together.

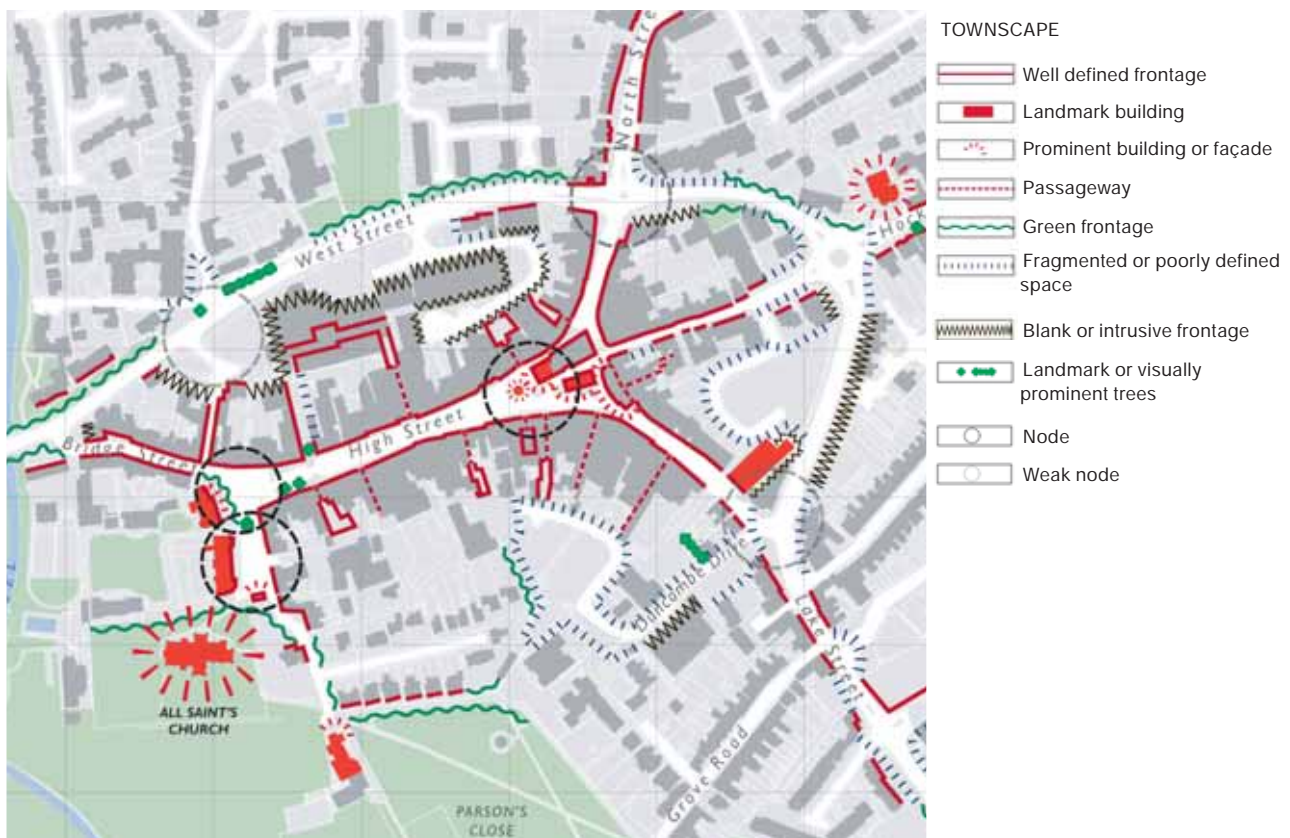

A townscape appraisal identifies the specific elements that give a place its identity.

Mapping © Crown copyright. All rights reserved Licence Number 100018816, 2010

## A3.7 Technical constraints

Technical constraints on the site should be set out, ideally on an annotated plan. The main constraints are likely to be:

- Floodplain
- Slopes
- Ground conditions
- Infrastructure wayleaves or easements
- Noise and other nuisances
- Designations
- Boundary conditions and overlooking.

Depending on the location of the site and the size of the proposed development, a Flood Risk Assessment may be necessary, subject to discussions with the Local Planning Authority.

Similarly, depending on the location of the site, a Ground Stability/Coal Mining Risk Assessment may be necessary where there has been a history of mining and subject to discussions with the Local Planning Authority and Coal Authority.

Discussions on drainage and SuDS must be supported by initial appraisal work to establish:

- The soil and hydrological conditions in the area
- The regimes of the statutory undertakers for foul and surface water sewerage
- Rights of discharge.

The output of the technical constraints appraisal should be a constraints plan and a report as necessary to set out any detailed information about the parameters of the constraints.

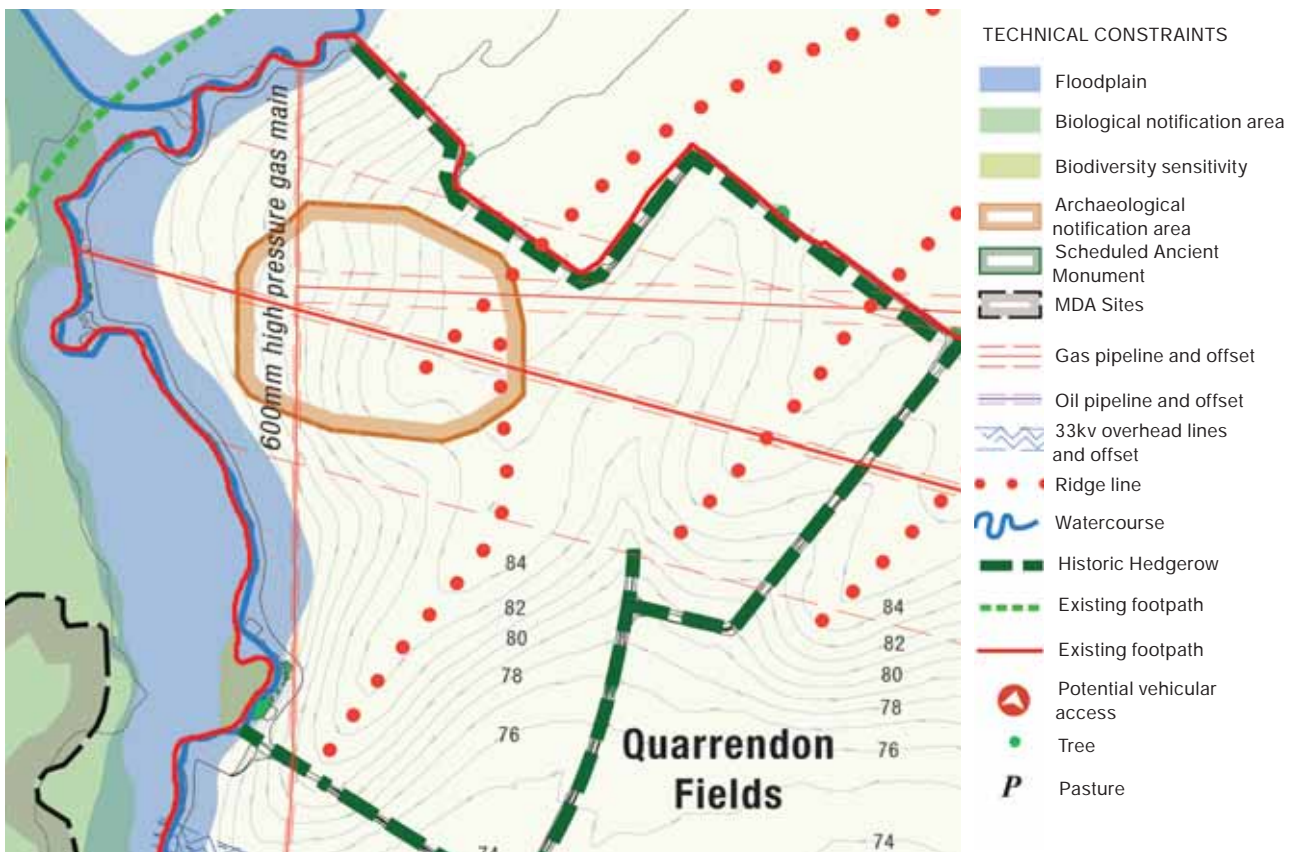

An essential part of the appraisal is to identify the key constraints affecting the proposed site.

Mapping © Crown copyright. All rights reserved Licence Number 100018816, 2010



# 3.2

## Neighbourhoods

**Building for Life criteria**

- 1** Does the development provide (or is it close to) community facilities, such as a school, parks, play areas, shops, pubs or cafes?
- 4** Does the development have easy access to public transport?
- 6** Is the design specific to the scheme (the location and its character)?
- 13** Are the streets pedestrian, cycle and vehicle friendly?

**Core principles:** integrated, vital, equitable, local, efficient



The pattern of main and neighbourhood centres within a settlement. Proposed new development to the north includes a new centre to extend the pattern of centres

## N1 Neighbourhoods and centres

All new development must be part of a neighbourhood that has an identified centre providing local services and facilities.

- In the case of large scale proposals, the development may (as determined in discussion with the Local Authority) need to create a new centre. In the case of smaller scale, more isolated development it must still lie within the catchment of an identified centre (or centres) with services and facilities.

If the scale of development requires additional non-residential facilities, the development must reinforce or extend the existing pattern and hierarchy of centres, adding facilities as part of an existing or new centre.

- Centres should be designed and function as a common resource, not for the exclusive use of a limited area/development.

While the subject of this guide is residential development, it is clear from existing settlements and research that the most successful residential environments make up or are part of a **neighbourhood** that includes associated uses, facilities and services such as local shops and offices, schools, community facilities, public open space and recreation.

Perhaps the single most important element in seeking to achieve the core principles is the neighbourhood. The neighbourhood is central to all of those principles as well as to the Building for Life criteria and Lifetime Neighbourhoods.

In general a neighbourhood is made up of a centre formed by a concentration of services and facilities in an accessible location with a surrounding area of residential streets or 'catchment'. An equally important associated idea is the hierarchy of centres that provides the full range of services and facilities to a given area:

- Main
- District
- Neighbourhood.

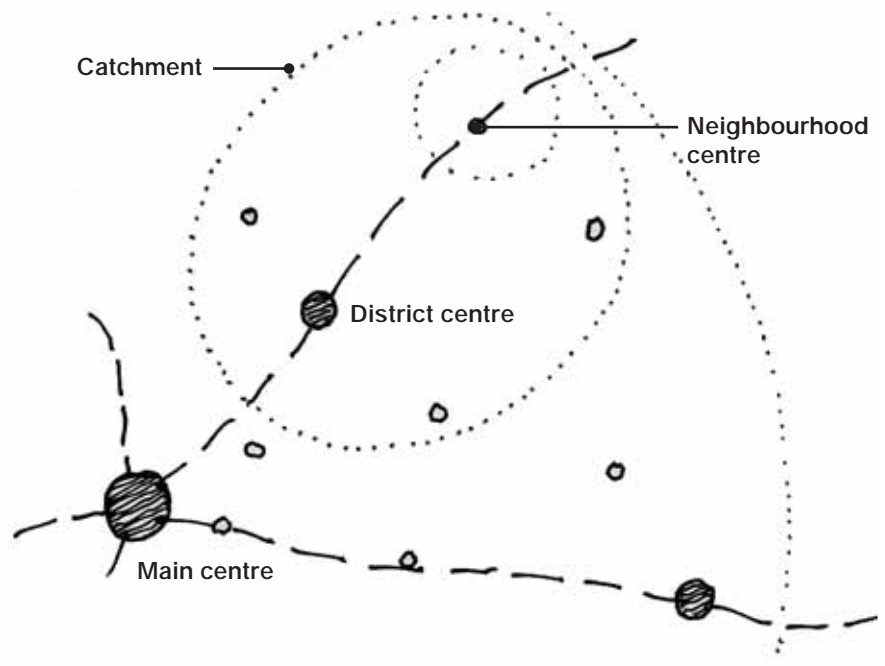

Fig 2.4: Hierarchy of centres  
Each of the different kinds of centre has its own catchment. The main centre has the largest and neighbourhood centre the smallest

## N1.1 Facilities and services

The design of all new development must be based on an appraisal of the neighbourhood(s) (see A3.1) in which it is located, identifying the facilities and services available to support the development. This part of the appraisal is best done in conjunction with the appraisal of streets and movement.

The appraisal and proposal must demonstrate that new development is served by a range of facilities accessible to all, taking into account public transport, located in one or more centres including where appropriate:

- Employment
- Education
- Health care
- Community facilities (e.g. halls, meeting rooms, libraries etc.)
- Administrative offices
- Places of worship
- Retail and services (e.g. post office, bank, council offices)
- Food and drink
- Leisure and recreation
- Parking
- Publicly accessible toilets
- Cash point
- Open space

*As defined above, centres are facilities-based focal points with a surrounding catchment of principally residential areas. A greater degree of integration, vitality, inclusiveness and efficiency is achieved with a mix of uses in the centre that attract people at different times for different reasons.*

- The effective minimum for a centre is a 'corner shop' or convenience store, newsagent, post office or other 'generalist' retail (including within petrol filling stations). Combinations of two or more specialist shops can also constitute a local centre. Within a larger built up area with overlapping catchments, a minimal centre is supported, as a rough guide, by a minimum of between 800 and 1,200 dwellings.
- A full neighbourhood centre includes a larger number and wider range of uses and is supported, again as a rough guide, by between 1,800 and 2,500 dwellings within a built up area with overlapping catchments.



*The main centre in Thorne includes a mix of uses that creates a vibrant, vital environment and a strong identity.*



*Non-residential uses can be integrated into new development to create a centre for a new neighbourhood.*

## N1.2 Accessibility

**All submissions must demonstrate that the proposals achieve the levels of accessibility set out in the relevant policy documents.**

*Accessibility of facilities and services is fundamental to the proper functioning of a neighbourhood. Development Plan Documents (DPD) set out policies and criteria for accessibility.*

*Some of the implications of the broad accessibility targets for the layout of residential areas are, in summary, as follows.*

Distance from residential areas in:	to:	local services	bus/tram stop	primary health/education
main centre		10 min walk	5 min walk	20 min journey
central area		15 min walk	5 min walk	30 min journey
central area (smaller town)		20 min walk	5-10 min walk depending on destination	20 min walk 30 min journey
corridor		15 min walk	5-10 min walk depending on destination	20 min walk 30 min journey
rural settlement	(via bus)		10 min walk	40 min journey

- As a general rule of thumb a 5 minute walk equates to a distance (actually travelled rather than straight line distance) of 400 metres for non-disabled people. For different groups of disabled people, these distances are significantly less. Account must be taken of indirect routes and topography in estimating walking times. The design should also take account of the needs of disabled and older people, including regular opportunities to rest safely on key routes.
- In order to achieve accessibility for as wide a range of users as possible, appropriate levels of public transport and inclusive design standards need to be adopted from the outset, taking into account such factors as:
  - Public transport infrastructure
  - Pedestrian routes and facilities
  - Safety
  - Cycle routes and bicycle parking
  - Safety management
  - Traffic speeds
  - Publicly accessible toilets (including accessible facilities)
  - Seating to accommodate all users
  - Parking, to include accessible parking.

### N1.3 Neighbourhoods, density and location

All new development should reinforce the pattern of density found in the area, particularly in relation to the main centre and any sub-centres.

- The nature and character of places tends to vary with their location relative to the main centre of the settlement and any sub-centres. In larger settlements, the variation from the main centre to the edge of the settlement and beyond leads to five principal types of position:
  - Main centre
  - Central area
  - Main route and transport corridor
  - Suburban
  - Rural.
  
- In general, densities increase moving from rural and edge locations to the main centre and toward district and neighbourhood sub-centres.

The neighbourhood appraisal and other supporting material must identify the location of the site within the settlement as a whole as well as proximity to nearby centres. The material must also demonstrate that the proposed density is suited to the identified location and its character. (see Section N2)

- The most appropriate place for higher densities is in close proximity to centres. The appropriate density for a particular location should be gauged along two axes: from main the centre to the edge of the settlement and from the sub-centre to the edge of the catchment.
- While these gradients provide a general guide, the acceptability of particular densities will be dependent on specific local policies and the character of the immediate area.
- The appropriate density for a given location should be based on an average for a wider area and allow for local, small scale variation.
- Uniform densities over whole neighbourhoods should be avoided.

*The range and intensity of activities and the density and scale of development are fundamental aspects that contribute not only to the character but also sustainability of places. Locating more activities and higher density in close proximity to centres helps to make facilities and services more accessible to more people and also helps to secure the vitality and viability of the centres.*

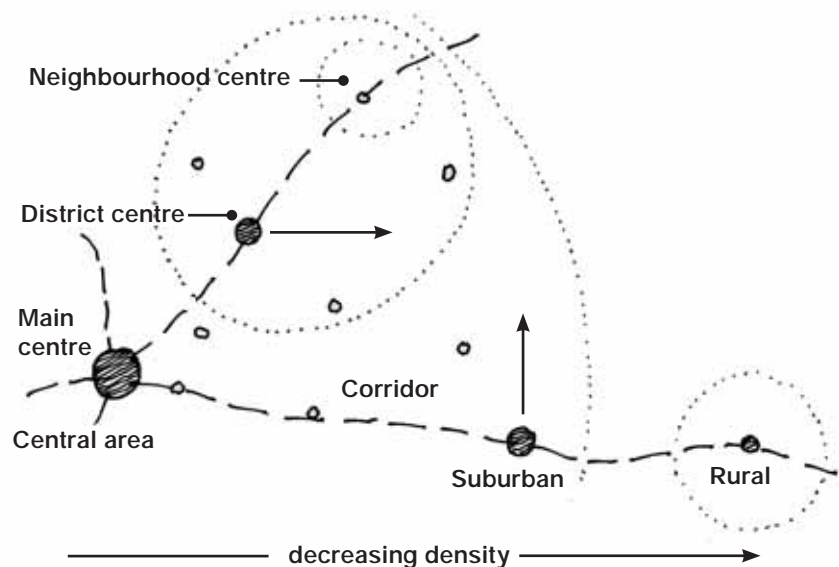



The buttercross in Tickhill creates a community focal point with a strong identity



Trees make this space in North Masbrough more comfortable



A good community focal can be a simple widened area of pavement that gives people a place to stop and chat

## N1.4 Community focal points

In addition to facilities-based centres all new development should have access to or create community focal points that are well located, accessible and safe and reinforce or extend the network of community focal points within a neighbourhood.

*A community focal point is a place 'where paths cross' and people might meet, stop and carry on a conversation.*

*As a bare minimum a community focal point should be a space within the public realm in addition to the minimum needed for movement. The space should be for pedestrians only, including wheelchair and scooter users. It should allow for at least two people to stop comfortably without being physically disturbed by passing pedestrians.*

*The most successful focal points are extensions or widenings of common spaces within the public realm such as a street or square. They are best if not overdesigned as single-purpose features but part of a principal component.*

- A community focal point should also include:
  - Inclusive seating (with seatbacks and armrests)
  - Space for wheelchairs and scooters
  - Lighting (not necessarily in addition to street lighting)
  - A landmark (tree, monument, signage, special building, public activity).

*Examples include:*

- Widened pavement within a residential area or centre
- Public transport stop
- Space associated with a junction of streets
- Small 'square' or 'piazza' associated with publicly accessible buildings
- Play area/ pocket park .
- Community focal points should be well overlooked and located along or adjacent to main lines of movement, ideally at a crossing or meeting point of two or more main lines.
- Routes between focal points should be distinguished as more important, 'active' or 'special' routes.
- Focal points and the routes between them are appropriate locations for special architectural treatment.
- Smaller public open spaces associated with individual developments or buildings must be an integral part of the public realm. They will be considered as focal points and must meet the requirements set out above.
- Spaces that are poorly located, inappropriate in slope, shape or size to fulfil a definite function will not be acceptable.
- New development should extend the public realm as a continuous network of street spaces connecting focal points. Focal points should be closer together and so more numerous around main centres and may be progressively less frequent in locations further along the gradient toward rural settlements.
- The network of focal points should complement and reinforce the pattern of streets and the differences between them. For example, focal points should be more frequent along main routes.
- Similarly, they should be used to highlight elements within the green infrastructure and neighbourhood structure.

## N1.5 Recreation, public open space and other landscape dominant uses

Proposed public open space, recreation grounds and other landscape dominant community uses such as allotments should be well located in order to be accessible, actively used and safe and well integrated into the green infrastructure and landscape framework.

*In developments of a sufficient size, there will be a requirement for public open space, recreation and school places. All of these, though more actively managed, should be considered as potential elements within the green infrastructure. Once areas for drainage and habitat have been identified, public open space can be used to tie them together into a connected network.*

- Locate new public open space and landscape dominant features such as schools adjacent to existing green infrastructure features, both outside and within the site, in order to help integrate, consolidate and extend the network.
- Locate public open spaces along or just off/immediately accessible from principal routes.
- Place schools, playing fields and formal recreation on flatter parts of the site.

*In order for it to be meaningful, safe and actively used, public open space must be well located and visible from other public spaces, most importantly, from streets.*

- Public open space must be an integral part of the public realm in addition to being part of the green infrastructure. Required areas of formal and informal public open space must be located along and visible from main lines of movement.
- Spaces should be well overlooked.
- Adequate buffer spaces should be included in line with Fields in Trust (formerly the National Playing Fields Association) standards to avoid conflicts with other uses.
- Public open space must serve a definite function. Spaces that are poorly located, whose function is ambiguous, inappropriate in shape or size to fulfil a role will not be acceptable.
- Future maintenance requirements, including street furniture and lighting, should be a principal consideration in the location and design of public open space.



*This public open space in the Crookes district of Sheffield is well overlooked and is part of the wider green infrastructure*

**Building for Life criteria**

- 6** Is the design specific to the scheme?
- 7** Does the scheme exploit existing buildings, landscape or topography?
- 8** Does the scheme feel like a place with distinctive character?
- 9** Do the buildings and layout make it easy to find your way around?
- 10** Are streets defined by a well-structured building layout?

**Core principles:** integrated, vital, equitable, local



*Rolling countryside and distant ridges near Silkstone Common, Barnsley*



*Subtle changes in level on the rural edge of Conisbrough, Doncaster*

## N2 Character

The design of all new development must be based on an appraisal of existing landscape and settlement character. (see A3.2)

**New development should maintain or enhance the positive character and identity of the area in which it is located and help to maintain the character of the wider landscape.**

- The appraisal should make reference to existing Landscape Character Assessments (LCA) and the South Yorkshire Historic Environment Characterisation (SYHEC).
- Reference should also be made to the disposition of development relative to topography, water courses and woodland as well as plant species and building materials.
- Where the character is positive and fits with other objectives, new development should share characteristics with existing types and patterns of development in the locality.
- Positive character is defined as a combination of characteristics that:
  - Is viewed as positive by the wider community
  - Is identified by the local community as important to the life and identity of the place
  - Can be identified as of special architectural, historical or artistic interest
  - Adheres to the standards and criteria set out in this Guide.
- Characteristics and features of an area that are at odds with the criteria and standards of this guide will not be acceptable merely because they are local.

*Character and identity are rooted in the historic development of a place and the range of design solutions that have been generated in response to the specific conditions and circumstances presented by that place. While some of our needs and circumstances change over time (for example with the use of the motor car), many of the specific conditions of the place remain the same (topography, for instance). We should, therefore, expect to see both continuity and change in the form of built development over time.*

*In the appraisal and design stages, local identity should be seen not as a flat backdrop but a range of previous attempts to solve design problems, not a museum of pictures but a library of ideas that can be used and adapted.*

### Landscape and identity

What is the character and identity of South Yorkshire? On the less tangible side, character is a common idea rooted in history and the importance placed on certain values and ways of life. On the more tangible side, it begins with the wider landscape.

Perhaps the first thing to be said is that it is not uniform. Not only is South Yorkshire divided into four separate unitary authorities, it is made up of a number of different landscapes. The differences between them can be summed up by drawing a line running from the Pennines in the west through Sheffield, Rotherham and Doncaster to the Ouse and Humber in the east.



An open view of undulating hills near Wentworth, Rotherham



© copyright Alan Heardman and reproduced under the Creative Commons License

View east from the Pennine Fringe toward Totley and Dore

Travelling that line and referring to the National Character Areas produced by Natural England as shown in the map below, one passes from the high moorland of Dark Peak, through the pronounced valleys and gritstone villages of the South Yorkshire Pennine Fringe and on to the more varied Nottinghamshire, Derbyshire and Yorkshire Coalfield with its mix of built-up areas, industrial land and farmed open country. Continuing eastward takes you over the rolling hills, farmland and wooded estates of the Southern Magnesian Limestone, which forms a distinct barrier between the industrial coalfields in the west and the flat, glacial Humberhead Levels to the east.

In essence, there are five bands of different character oriented north-south, which are crossed by South Yorkshire as it extends east to west.

The Nottinghamshire, Derbyshire and Yorkshire Coalfield area lies at the centre of the five bands and includes the majority of the urban areas, notably, Barnsley, Rotherham and most of Sheffield. The underlying coal was central to the development of the industrial revolution and so the transformation of the landscape. This is reflected in the Historic Character Reconstruction, which highlights the central mixed residential and industrial zone corresponding to the Coalfield area.

The broad identity of South Yorkshire is thus intimately tied to its location between the key geographic features of the Pennines and the Humber and the historical development of the area, again rooted in the land and the resources that lay within it.

The Natural England National Character Areas in South Yorkshire

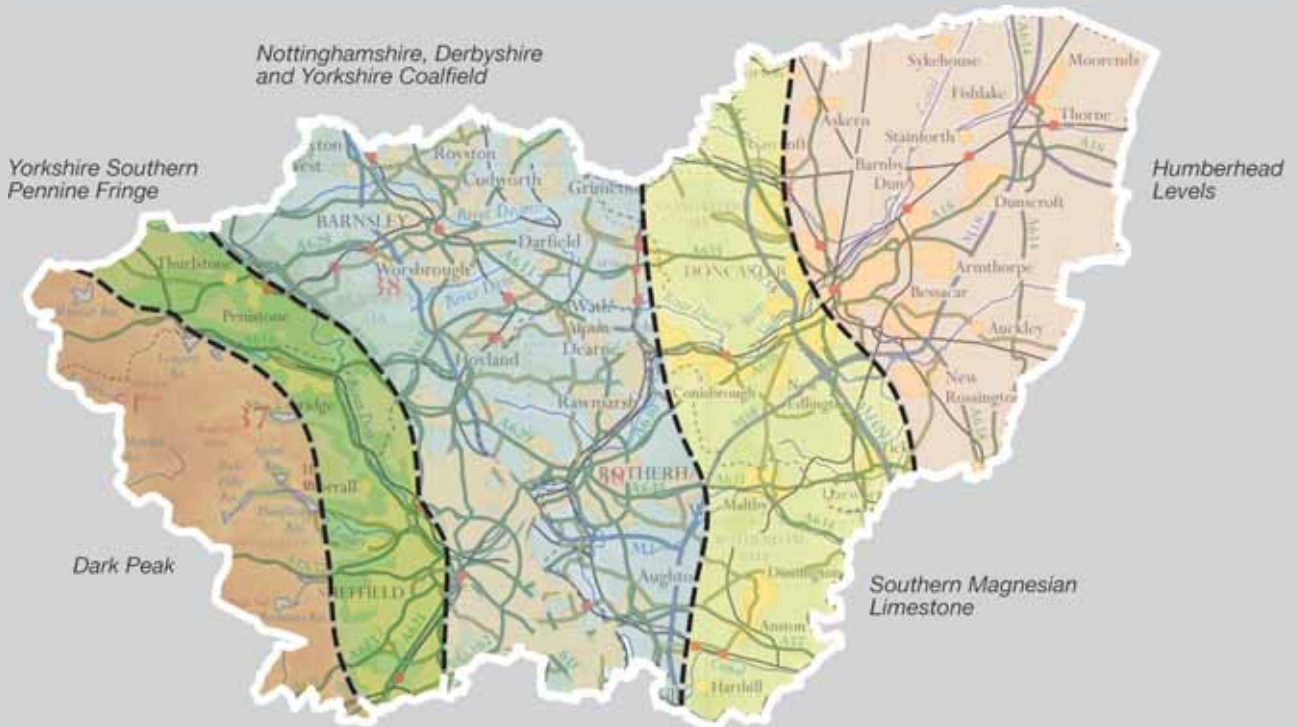

(Map compiled from Natural England National Character Area maps, www.naturalengland.org.uk)



*A rural village scene at Cawthorne, Barnsley*



*Gritstone terraced housing in Crookes, Sheffield, stepping down the hill*



*Terraced housing at Treeton, Rotherham, is typical of industrial villages*



*An example of mid-20th century development at Bessacar, Doncaster*

### The uses of landscape character in design

In addition to the National Character Areas referred to above and the national Character of England Map, there are a number of landscape character assessments that have been carried out at the local level:

- Rotherham Metropolitan Borough Council Landscape Character Assessment 2010
- Peak District National Park Authority, Peak District Landscape Character Assessment 2008
- Doncaster Metropolitan Borough Council, Landscape Character Assessment and Capacity Study of Doncaster Borough 2007
- Barnsley Metropolitan Borough Council, Barnsley Borough Landscape Character Assessment 2002
- MAFF North Peak Environmentally Sensitive Area Landscape Assessment 1994.

The character areas and descriptions produced by the assessments provide a useful resource in design. First and foremost, they give a general overview and frame of reference for understanding the details of an area.

Most pertinent to the design of residential areas, the character descriptions indicate the disposition of development with respect to topography, water courses and woodland that is characteristic of the area as well as typical building materials. As set out in N2, the starting point for design should be that proposals share characteristics with the locality in order to retain its identity.

### Settlements and identity

The towns and villages of South Yorkshire and the city of Sheffield are a part of the landscape and have been created out of it. The settlements take their character in part from the activities that the landscape supports, such as farming, mining and industry, in particular steelmaking, as well as from the physical materials the landscape provides such as limestone, gritstone and clay for bricks and tiles.

The character of settlements is also deeply rooted in their historical development. The South Yorkshire Historic Landscape Characterisation identifies a range of different kinds of settlement based on their historic origins and the changes they have undergone over time. There are, for example, the larger settlements with complex historic centres such as Sheffield, Rotherham, Barnsley, Doncaster, Conisborough, Mexborough, Thorne, Bawtry and Tickhill. At the other end of the spectrum are the compact rural settlements such as Hatfield Woodhouse, Fishlake and Fenwick, Cawthorne, Little Houghton and Billingly, Harthill, Ravenfield and Hooton Levitt. In between are the many settlements that grew up as industrial villages around a rural village core or have grown with more recent development.

The range of settlement types varies within the different local authorities. Sheffield has an extensive urban area with a distinct historic core and varied central and peripheral areas. Barnsley has many small industrial settlements while Doncaster has most of the smaller complex historic towns. Rotherham is a mix with suburbs focused around Rotherham and more rural areas of smaller villages to the north-west and south-east.

## N2.1 Character areas

The character appraisal should identify the wider landscape character area and settlement type in which the site is located. The result should then be the identification of distinct local sub-area that forms the immediate context of the site. The primary design source for maintaining character should be the character area in which the site is located.

If the area is not deemed a positive source, a new and distinctive character should be established, but with clear reference to other local areas to help maintain the character of the wider area.

- Where possible, reference should be made to characterisation studies that have already been done such as Conservation Area Appraisals and the South Yorkshire Historic Environment Characterisation.
- The basis of the appraisal should be to examine the locality in terms of both objects such as streets, plots and buildings, and the way that they are laid out or arranged, which is to say, in terms of patterns. The appraisal should identify character areas in terms of the types and patterns of:
  - Streets
  - Blocks and plot series
  - Plots
  - Buildings
  - Details and materials.
- In general, the 'unit' of character will most likely be the street. Most character areas are made up of a single street or combination of streets.



These photographs illustrate the character area identified on the plan to the right

Example of a character area, outlined in plan, that shows a consistent pattern of streets, plots and building type. Mapping © Crown copyright. All rights reserved Licence Number 100018816, 2010

## N2.2 Specific features

The design of all new development must be based on an appraisal that identifies any existing positive features within the site and assesses the advantages and disadvantages of retaining them.













Existing positive features should be retained and form the basis for the layout of new development.

*While character areas provide a general framework for retaining local distinctiveness, it is essential to recognise that local character and identity are most crucially rooted in the specific features of the site. A strong sense of place arises when those features are actively used in the design. A scheme that proposed a form of development copied from an adjacent area, for example, but that did not adapt it to the particular features of the site would fail to maintain the identity of the place.*

- Use existing points of access and integrate or adapt existing routes.
- Reuse or adapt existing drainage features.
- Use or follow the line of existing boundaries for new boundaries or other features such as streets or corridors.
- Retain and enhance existing trees, hedgerows and other vegetation, ideally as part of the public realm or otherwise as appropriate to the circumstances.
- Retain and integrate existing buildings.
- Protect and enhance heritage assets and integrate them into the design to add time depth to the character of the proposed development.
- If character areas (or sub-areas) are created within new development they should be derived from existing features or specific locations within the site.

*For example, an existing street, landscape feature or view should form the basis for a character area, as could a retained building or topographic feature.*

OPPORTUNITIES AND CONSTRAINTS

Buildings with potential for active uses	
Schools	
Community facilities	
Conservation area	
Trees	
Playing fields	
Neutral, semi-improved grassland	
Existing footpaths	
Bus routes	
Key node	
Key views	
Existing route structure	



*A diagram illustrating opportunities and constraints and highlighting the specific features such as buildings and trees that give the locality its identity*

Mapping © Crown copyright. All rights reserved Licence Number 100018816, 2010

**Building for Life criteria**

- 5** Does the development have any features that reduce its environmental impact?

**Code for Sustainable Homes criteria**

Ene 1, Dwelling emission rate,  
Ene 7, Low and zero carbon technologies

**Core principles:** integrated, efficient

## N3 Local resources, energy and carbon dioxide reduction

The design of all new development must be based on an appraisal of the site and surroundings assessing the potential to use renewable/low carbon sources such as solar, wind, biomass or ground source heat as well as the capacity of mains services (see A3.3).

**A Sustainability/Energy Statement must be submitted that demonstrates how much energy is expected to be used in the proposal and the source of the energy. It should also show how the scheme will meet any policy requirements for reduction in carbon dioxide emissions and percentage of energy from renewable sources. The information required should be commensurate with the scale of development and subject to discussion with the Local Planning Authority.**

*An overarching consideration with regard to energy use is the national commitment to reduce carbon dioxide emissions and increase renewable generation of energy. To help meet these targets, the first questions to be asked when assessing a site for development are: what can be done to reduce demand and what resources are available locally to sustain the development? First and foremost, if development is to occur, it should make the most of the assets and opportunities of the area. What are the benefits of the location?*

### N3.1 Renewable and low carbon energy sources

The source of renewable and/or low carbon energy should be identified at an early stage in the design process in order to understand the implications for design.

**It is of particular importance to identify whether the source will be located within individual dwellings, the site or at a district level.**

*There are a number of sources of renewable and low carbon energy that are currently viable and that need to be considered at the concept stage of the design process:*

- *Ground/air source heating and cooling*
- *Biomass/wood fuel heating – individual and district*
- *Solar – space heating, hot water and electricity*
- *Wind – natural ventilation and electricity*
- *Gas combined heat and power (CHP) – individual and district*
- *Energy recovery from waste – district.*

*Ground/air source heat, solar and biomass are the most likely to be viable for individual properties. Biomass heat and wind generated electricity are more cost-effective when used as a source at the district level. Micro-gas CHP is currently in development but not yet commercially available.*

*Because the Code for Sustainable Homes deals in detail with individual dwellings, the emphasis here is on how the arrangement of buildings can help in using renewable sources. Because solar and wind sources are available everywhere and have a number of different uses, they are looked at in more detail.*

## N3.2 Solar

**New development should optimise solar access, in balance with other considerations.**

*Solar energy is perhaps the most basic resource and should be a primary consideration in evaluating a site in terms of potential for use of passive solar energy for space heating, daylighting and moderation of microclimate as well as active solar energy for hot water and electricity.*

- Proposals should be based on a sun-shade/solar access analysis of the site.
- Key considerations:
  - Topographic orientation of the site
  - Orientation of streets
  - Orientation of buildings
  - Overshadowing by adjacent buildings and vegetation.
- Sites on south facing slopes will clearly have significant advantages for maximising solar gain and should be considered preferable for new development. Similarly, sites in narrow valleys and low on north facing slopes present particular challenges and will therefore require careful attention in terms of the orientation of buildings:
  - Orient streets as far as possible to run within 30 degrees of east-west
  - Orient buildings with long sides facing within 30 degrees of south
  - Arrange buildings to avoid overshadowing.
- Achieving good solar orientation should not be at the expense of other design considerations such as creating active frontages, providing inclusive access, maintaining existing natural features or achieving slow traffic speeds.



*Making use of passive solar energy needs to strike a balance between best access to sunlight and maintaining an active frontage along the street*

## N3.3 Wind

The appraisal of local energy resources should make reference to available information on prevailing wind speed and direction for use in energy generation and natural ventilation and demonstrate whether it is viable or not.

### Ventilation

In balance with other considerations, new development should optimise wind driven natural ventilation.

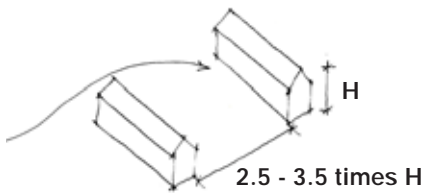

*Spacing of buildings to optimise natural ventilation*

- As far as possible orient buildings across to prevailing winds to generate cross ventilation in buildings.
- Orient buildings with long sides perpendicular to prevailing winds.
- Space buildings to avoid wind shadow, best between 2.5 and 3.5 times building height, along the line of the prevailing wind.
- Avoid long straight routes parallel to prevailing winds, which produce wind tunnel effects.
- In South Yorkshire prevailing winds tend to be from the south-west to south-east. The ideal orientation for both wind and solar access therefore correspond.
- As with solar orientation, achieving good wind orientation should not be at the expense of other design considerations.

### Energy

*Recent experience and research suggests that domestic wind turbines have limited capacity to contribute to renewable energy supplies. Only tall buildings on exposed sites are likely to be viable. Wind energy for electricity is most likely to be viable at a neighbourhood or district scale using larger turbines. Larger proposals should therefore investigate the viability of district wind power taking into account, amongst other things:*

- *Wind speed and persistence*
- *Proximity to existing development*
- *Landscape and visual impact*
- *Habitat.*

*As a general rule, large turbines are only technically viable with wind speeds over 6 metres per second at 45 metres above ground level.*



*Trees at Wadworth, Doncaster (top) and Millhouses, Sheffield (above) make a significant contribution to the quality and comfort of the environment*

## N3.4 Microclimate

**All new development should work to moderate extremes of temperature, wind, humidity and pollution within the site and, as far as possible, the surroundings.**

*In order to create an environment that is comfortable for as wide a range of users as possible, it is essential to assess the microclimatic conditions of the site and surroundings. In simple terms, there needs to be enough, but not too much:*

- Warmth and light
  - Shade
  - Cooling breeze
  - Shelter.
- Public spaces and focal points should have direct sun for a significant proportion of the day, as far as possible over the whole year.
  - Shade should be provided in streets, spaces and focal points that receive direct exposure to midday and afternoon sun.
  - Trees should be used as the preferred source of shade because of their many other benefits (see below).
  - Avoid low lying contained spaces which may be dark and prone to frost due to sinking cold air.
  - Avoid narrow, unprotected gaps in lines of buildings perpendicular to prevailing winds, which also produce wind tunnel effects.

### Trees

*Trees are one of the most effective means of improving microclimate. They:*

- Moderate temperature extremes and reduce heat island effects
  - Provide shade while still allowing through light
  - Provide shelter from wind.
- They also:*
- Improve air quality
  - Provide habitat
  - Reduce pollution (some species)
  - Have potential as a source of fuel as part of a larger plantation.
- Use trees on exposed sites to provide wind breaks.
  - Shrub planting can also be used for windbreaks and to avoid the extremes of frost pockets.
  - On larger sites include blocks of tree planting as a multi-functional element of the green infrastructure, serving as community woodland, habitat, soil retention and a source of wood fuel and timber.
  - The choice of tree species must be suited to the location and conditions in terms of height, spread, type and density of foliage and root behaviour, amongst other characteristics, to ensure there is no adverse impact on safety and character.
  - It is essential to establish at the outset an agreed maintenance regime for all tree planting and identify the body responsible for maintenance.

*See Technical Requirements Section 3G for guidance on trees*

## N3.5 Utilities infrastructure

**Information on the capacity of mains utilities must be included in the Sustainability/Energy Statement or Design and Access Statement.**

*The location of utilities infrastructure with a potential impact on masterplans such as major pipe runs, pumping stations or electricity sub-stations should be identified in principle at the concept stage in order to ensure efficient and effective functioning and avoid compromising other principles.*

### Code for Sustainable Homes criteria

Sur 1, Management of surface water run-off from developments  
Sur 2, Flood risk

## N3.6 Surface water drainage

**Proposals should as far as possible use the principles of sustainable drainage systems (SuDS) to deal with surface water drainage. Sustainable drainage systems should be seen as part of an overall strategy that includes flood avoidance, management, resistance and resilience as appropriate to the site.**

**Sufficient space must be included within the proposals to accommodate retention of run-off as necessary. The drainage strategy, including principal SuDS features, must be included in the concept stage submission.**

**Future maintenance of the drainage system must be a primary consideration from the start of the design process and specifically included in the drainage strategy.**

**On site features such as green roofs and water butts should be considered as part of the strategy.**

- It is essential for developers to agree with the Local Authority and water companies the type and extent of any SuDS proposals at an early stage in the design process and establish who will adopt and maintain the scheme and what level of commuted sum is likely to be required.
- As far as possible retain existing open drainage features and integrate them into designs as a spine for the green infrastructure.
- Minimise changes to topography and drainage patterns.
- Larger soft SuDS features should be treated as part of the multi-functional green infrastructure and as far as possible accommodate a range of appropriate uses.
- As far as possible, smaller soft features and hard features should be integrated into street or public space. Any such features or permeable surfaces must be suitable for disabled people.
- Flood risk is an important issue in South Yorkshire. All residential development needs to consider flooding from all sources such as river, surface water, groundwater, sewer. Refer to the Environment Agency flood maps and the relevant Council's Strategic Flood Risk Assessment (SFRA) to identify areas at risk of flooding. A further response to flood risk promoted by the Environment Agency and other organisations is 'flood resilience', which aims to minimise the damage from flooding by layout, construction details and choice of materials.
- Flood resilient design is appropriate for areas of low or residual flood risk or areas where flood risk management or mitigation measures have been put in place. The appropriateness of applying resilient design on a particular site should be determined through discussion with the Local Authority.

*More detailed technical advice on SuDS is included in Technical Requirements Section 4C and the Interim Code of Practice for Sustainable Drainage Systems published by the National SuDS Working Group (available from CIRIA) though this is subject to review under the Flood and Water Management Act 2010. On flood resilience, see Improving the Flood Performance of New Buildings – Flood Resilient Construction (2007) as well as the CIRIA publication C688 Flood resilience and resistance for critical infrastructure (2010), which includes principles applicable to residential development.*

#### Code for Sustainable Homes criteria

Was 1, Storage of non-recyclable waste and recyclable household waste

## N3.7 Waste recycling and collection

**All new development must be designed to accommodate the waste and recycling regimes in force.**

**The location and appearance of waste/recycling storage must not have a detrimental effect on the function, appearance and character of the public realm or shared private space.**

- The principal considerations for accommodating waste and recycling are:
  - Sufficient space to store material both individually and communally
  - Easy access for all to the point of collection
  - The function, appearance and character of the public realm or shared private space.
- To avoid detrimental effects on the public realm and shared private space:
  - Bins should not be visible from within the public realm or shared private space when stored
  - Storage areas should be within the principal envelope of the building where compatible with collection regimes
  - The location and design of storage areas should help avoid or deter vandalism and arson
  - External storage enclosures must be inconspicuous and made of high quality materials to match or complement the building.



*The traditional 'ginnel' is a robust and adaptable feature that allows for access to waste and recycling storage that remains out of view*



*If frontage storage is the only option it should be well integrated into the building design*

**Building for Life criteria**

- 5** Does the development have any features that reduce its environmental impact?
- 6** Is the design specific to the scheme?
- 7** Does the scheme exploit existing buildings, landscape or topography?
- 8** Does the scheme feel like a place with distinctive character?

**Code for sustainable Homes criteria:**

Eco 1, Ecological value of site  
 Eco 2, Ecological enhancement  
 Eco 3, Protection of ecological features  
 Eco 4, Change in ecological value of site

**Core principles:** integrated, vital, local, efficient

## N4 Green infrastructure, vegetation and habitat

The design of all new development must be based on an appraisal that identifies existing vegetation and habitat on the site and its surroundings and assesses the advantages and disadvantages of retention (see A3.4).

New development should establish and be built around a landscape framework that consolidates and integrates existing and proposed green features to complement or extend the wider green infrastructure.

Particular attention needs to be paid to the design of development on the edge of a settlement. The treatment of the outer edge of the settlement should enhance the character and quality of both the settlement and countryside.

*Broadly, green infrastructure is the network of natural and managed green areas that provide a number of different 'services' to both humans and wildlife in, around and between settlements. Its most important features are that it is, ideally, a connected network and that it is multi-functional.*

- Green infrastructure should be thought of as a fundamental element of urban form. It should focus and condense natural activities in the same way that the street concentrates and channels public activity within built areas. Designs should ensure that each element has a definite and deliberate shape and function that complements the other.
- The edge treatment of a settlement should form a transition between countryside and settlement in order to bind the two together. Ideally, planting should be included as part of the boundary subject to an appropriate management arrangement. Overly simple, abrupt changes such as simple fencing should be avoided.

*Principal functions for the green infrastructure include:*

- *Surface water drainage*
- *Habitat/biodiversity*
- *Climatic buffer*
- *Accessible natural open space*
- *Wood products*
- *Food production (e.g. allotments or orchard)*
- *Visual buffer*
- *Informal and formal recreation.*
- As far as possible, multi-functional should mean a given feature is used for a number of different activities or purposes, for example, both surface water drainage and wildlife habitat. Account will need to be taken of the requirements of the various uses to ensure compatibility.



*The green at Wadworth, Doncaster, with its open area of grass and edge of trees, is a key element of the green infrastructure*



The orientation of a building might be adjusted to preserve and highlight mature trees



Existing trees can be retained within a landscape corridor to help ensure their long term survival



A simple plan showing the main elements of the landscape framework, including public open space, existing and proposed tree planting

- Countryside
- Fringe feature
- Woodland
- Farms
- Existing built-up area
- Public open space
- Landscape / street tree planting
- Retained / enhanced hedgerows
- Site boundary

Mapping © Crown copyright. All rights reserved Licence Number 100018816, 2010

## N4.1 Existing landscape features, vegetation and habitat

The design of all new development should protect and enhance valued, important or sensitive landscapes, habitats and landscape features

Green infrastructure is crucial for accommodating wildlife and maintaining biodiversity. Vegetation of various kinds and in particular trees also make a significant contribution to the character and quality of the built environment. As with drainage features, existing areas of vegetation within a site provide a basis for the form and layout of new development. In general it is preferable to retain existing vegetation and to do so within the public realm in order to ensure its long term retention and to gain maximum benefit from it.

- As far as possible extend areas of ecological value for wildlife and increase the range of species supported.
- Retain and incorporate (or replace) as much existing planting as possible in particular trees (refer to BS 5837:2005) and vegetation associated with drainage features.
- Retain trees, hedgerows and other vegetation within the public realm and allow sufficient space to ensure its survival and long term health.
- Where retention within the public realm is not possible or inappropriate, suitable measures should be put in place to ensure long-term retention of features.
- Treat climatic and visual buffers ('structural landscape') equally as habitat or, if sufficiently large, community woodland.
- Of all forms of vegetation, trees are probably the most versatile and beneficial. Include trees in the designs of public spaces, community focal points and selected streets, ensuring to allow sufficient space for the health of the trees and maintenance of surfaces and buildings.

## N4.2 The landscape framework

The combination of drainage features, habitat, buffers, public open spaces and landscape dominant uses should be integrated into a coherent framework.

- Connect features directly by placing them adjacent to each other or indirectly by tree-lined streets or green corridors.
- Consider near and distant views as a means of visually linking areas of green space.
- Treat the elements of the landscape framework as multi-functional and overlapping.
- Locate features to take best advantage of different locations in terms of topography, movement structure, neighbourhood structure and edge conditions.
- The landscape framework should be co-ordinated with and reinforce the network of public open spaces and streets (see N1.5 above and N5 and S2 below).
- Highlight key landscape features as part of the townscape.

**Building for Life criteria**

- 4 Does the development have easy access to public transport?
- 5 Does the development have any features that reduce its environmental impact?
- 6 Is the design specific to the scheme (the location and its character)?
- 8 Does the scheme feel like a place with distinctive character?
- 9 Do the buildings and layout make it easy to find your way around?
- 11 Does the building layout take priority over the streets and car parking, so that the highways do not dominate?
- 12 Is the car parking well integrated and situated so it supports the street scene?
- 13 Are the streets pedestrian, cycle and vehicle friendly?
- 14 Does the scheme integrate with existing streets, paths and surrounding development?
- 15 Are public spaces and pedestrian routes overlooked and do they feel safe?
- 16 Is public space well designed and does it have suitable management arrangements in place?

**Core principles:** integrated, vital, equitable, local, efficient

## N5 Street pattern and movement structure

The design of all new development must be based on an appraisal of the surrounding network of streets and pattern of movement through the area (see A3.5). This part of the appraisal is best done in conjunction with the neighbourhood appraisal.

- The appraisal should take account of all modes of movement and the needs of all people regardless of age, health or disability, and consider the following:
  - Existing routes, including public highways, footpaths, bridleways and permissive paths.
  - Route hierarchy: which are the main routes and which are lower order routes?
  - Location of key destinations such as employment areas, shopping facilities, schools, surgeries, health centres, parks and playgrounds, train, tram and bus stops etc.: how will future residents access these existing facilities by foot, cycle, public transport and car? How will residents of neighbouring areas access facilities to be provided in the new development?
  - Public transport routes and stops: do the existing facilities have sufficient frequency and capacity, how will they be accessed and do they need to be extended or improved?
  - Barriers to movement such as railways, waterways, motorways: what can be done to minimise their impact on the accessibility and permeability of the site?
  - Potential points of access: how can the site be integrated into the established movement structure? Are there opportunities to create direct links between the site and existing communities? These should be accessible to all modes of transport unless there are overriding reasons otherwise.
  - Safety: routes are much less likely to be used if they are, or are perceived to be, unsafe.
  - The accessibility of existing routes to disabled and older people, wheelchair and scooter users, people with children in pushchairs and any diversions which are currently required.
  - Potential improvements in inclusive design within the site and links to local services and facilities should be identified.

*The pattern and arrangement of streets and other rights of way determines how people move through an area and get access to a site. The way the pattern of streets and rights of way is actively used, taking into account all modes of transport, including walking, cycling, public transport and other motorised vehicles establishes the movement structure of an area.*

- On small schemes that do not involve the creation of new streets, the movement structure does still include the location and orientation of access from existing streets and movement through the site to individual dwellings.

**The movement structure must be one of the primary elements of the concept design. Plan the movement structure from the outset.**

*Getting the movement structure right will also affect a wide range of other issues, such as density, land use patterns, security and the integration of the site in the established urban area.*

**The movement structure must be the principal starting point for ensuring the development is both legible and permeable, which is to say, easy to find your way around.**

**Building for Life criteria**

- 6** Is the design specific to the scheme?
- 8** Does the scheme feel like a place with distinctive character?
- 9** Do the buildings and layout make it easy to find your way around?
- 14** Does the scheme integrate with existing streets, paths and surrounding development?

**Core principles:** integrated, vital, local

## N5.1 Route and place hierarchy

The design of all new development must be based on an appraisal of the existing street pattern that identifies the hierarchy of routes.

All new development that creates new streets must be an extension of the existing hierarchy and not simply based on the level of traffic flow. The design should reflect the importance of individual streets within the network and to the local community.

- The route hierarchy is strongly related to the hierarchy of places. Principal or primary streets in the hierarchy tend to connect main centres or destinations.
- The principal basis of the hierarchy is a combination of:
  - Levels of activity
  - Levels of movement (all modes)
  - Mix of uses
  - Connections.
- Higher order streets are busier and accommodate a greater variety of activities. Streets connected to more active streets have a higher order.
- Principal streets as defined in S1.5 and 4B.1.2.2 are higher order streets. Within a given area, the most active and important street directly connected to main destinations would be considered the 'Primary route'. In general, every turn away from the activity and connectivity is a drop in order to secondary, tertiary and lower order streets. Conversely, lower order streets can be defined as those that are several turns away from a primary route.
- The attributes of a legible and permeable street pattern include, amongst others:
  - Clear hierarchy of routes
  - Connected streets forming a network
  - Well defined street spaces
  - The inclusion of landmarks, community focal points or other open spaces at important points in the network.



*The route hierarchy: primary, higher order routes tend to connect one centre and another. Each turn off a primary route is a drop in level to more minor, local routes.*

**Building for Life criteria**

- 9** Do the buildings and layout make it easy to find your way around?
- 13** Are the streets pedestrian, cycle and vehicle friendly?
- 14** Does the scheme integrate with existing streets, paths and surrounding development?
- 15** Are public spaces and pedestrian routes overlooked and do they feel safe?

**Core principles:** integrated, vital, equitable, local, efficient



*The first consideration in the layout of a development should be access for the disabled and the full range of pedestrians*

## N5.2 Walkable neighbourhoods

**The movement structure must be developed in parallel with the neighbourhood structure and land use plan in order to ensure key facilities are accessible to all and located within walking distance. (see N5.6 below)**

*Encouraging people to walk is central to creating sustainable communities. Walking is not only the most environmentally-friendly mode of transport but it also enables informal interaction between people, creating cohesive communities.*

**Consider the needs of disabled people first by adopting inclusive design standards throughout.**

*This requirement is in line with the Disability Equality Duty. One strand of the duty is for local authorities to have due regard to the promotion of equality for disabled people in every area of their work, even if this requires more favourable treatment.*

**Consider the requirements of pedestrians and cyclists next, followed by other modes of transport as illustrated below:**

- Pedestrians
- Cyclists
- Public transport
- Specialist service vehicles (for example emergency services, waste etc.)
- Other motor traffic.

**Design the whole scheme around the routes that provide the easiest walking and, as necessary, accommodate public transport (see N5.3 below).**

**A pattern of streets that is easy to walk should have the following characteristics:**

- **Connected:** Routes should directly connect the places where people want to go. Barriers should be overcome for everybody and dead ends should be avoided
- **Legible:** It should be easy to follow routes and find key destinations, without relying on signage
- **Accessible:** Routes should follow pedestrian desire lines. Street crossings should be easy to use and safe. The topography should be carefully considered to minimise excessive changes of level on key pedestrian routes. Ramps and steps should be provided where the difference in levels is too great to accommodate a level route
- **Attractive:** Routes should be spacious and have comfortable surfaces. There should be community focal points, activity and variety along the routes to add interest to the walk
- **Safe:** Routes should be active, well lit and overlooked from fronting properties and within the street; different modes should use the same street space while keeping vehicle speeds low and conflicts between pedestrians and cyclists to a minimum.

- The characteristics that make a good walkable neighbourhood are the starting point for achieving the more specific qualities and requirements of the Safer Places checklists and Secured by Design certification.

**Building for Life criteria**

**4** Does the development have easy access to public transport?

**5** Does the development have any features that reduce its environmental impact?

**Core principles:** integrated, equitable, efficient



*Access to public transport is crucial to make the full range of facilities equally accessible*

## N5.3 Public transport

### All new development should be accessible by public transport.

- The design of all new development should enable all dwellings to be located within 5 minutes walk of a train, tram or bus stop, taking account of local topography and any other barriers. This should be seen as part of achieving the accessibility criteria in Section N1.2. and N5.2, above.
- Centres should have a train, tram or bus stop with frequent services within its immediate vicinity or at most within a five minute walk.
- The new layout should, as far as possible, create direct walking routes to the nearest bus stop or other public transport node. These should be accessible to disabled and older people including wheelchair and scooter users and people with children in pushchairs and should include resting places with inclusive seating and spaces for wheelchair and scooter users.
- If train, tram or bus services are absent or too remote from the site or there is not sufficient capacity on existing bus, tram or train services, early discussions must be carried out with the Local Authority, South Yorkshire Public Transport Executive (SYPT) and operators to identify the additional service(s) that should be provided and whether developer contributions will be required.
- If the size of the development requires extension of bus services within the site, the layout must be discussed with SYPT at an early stage. The layout must accommodate a convenient bus route suited to the needs of an efficient service. The design should be built around the transport route (but see N5.2 above). In general streets accommodating bus routes should be straight with direct connections to centres or main routes. The bus routes must be sufficiently wide, taking into account on-street car parking, as determined by vehicle tracking methods.
- Accommodating buses should not compromise other principles for the design of streets set out in this guide (see S1 and S2).
- New stops should be located, as far as possible, near centres or street junctions of main routes. Footways around stops should be wide enough to accommodate passing pedestrians as well as queues. Cycle parking at stops may also be appropriate. On local residential streets bus stops should be located within the carriageway rather than a lay-by.
- Sufficient transport provision must be in place as early as possible and keep pace with development phasing in order to establish sustainable transport patterns.

*Refer to Technical Requirements Section 4B.2.1 on widths and vehicle tracking and 4B.4 on speed restraint with regard to streets accommodating bus routes. See 4B.2.6 and Inclusive Mobility for guidance in relation to the design of stops.*

*Access to facilities and services is fundamental to creating sustainable communities. Public transport is in turn essential as an alternative to the private car both to reduce trips and for those without cars.*

**Building for Life criteria**

- 5** Does the development have any features that reduce its environmental impact?
- 13** Are the streets pedestrian, cycle and vehicle friendly?

**Code for sustainable Homes criteria:**

Ene 8, Cycle storage

**Core principles:** integrated, equitable, efficient

## N5.4 Cycling

The layout and detailed design of new development should ensure it is possible to easily reach centres and other main destinations by cycle.

*Research and experience show that one of the most effect ways of reducing car journeys is better provision for cycling.*

- By preference cycles should be accommodated within the carriageway to avoid conflict with disabled people and other pedestrians.
- Where cycles are accommodated off-carriageway, they should if physically possible be separated from pedestrians by means that meet the needs of visually impaired people such as a level difference ('step down to danger'), soft landscaped area or barrier.
- Preferred cycle routes (which is not to say separate cycle paths) should be identified with signage and publicised, ideally with maps of routes.
- All dwellings should have adequate cycle parking.
- Centres and other destinations should be designed or improved to accommodate cycle parking adequate for their size and location.
- Off-site improvements for bicycles should be included in the heads of terms for potential contributions.



*In addition to being an effective alternative to the car, cycling provides many other benefits*

**Building for Life criteria**

**11** Does the building layout take priority over the streets and car parking, so that the highways do not dominate?

**12** Is the car parking well integrated and situated so it supports the street scene?

**Core principles:** integrated, equitable, efficient

## N5.5 Parking strategy

**All new development must provide adequate parking that is fully integrated into the design.**

**A parking strategy should be established at an early stage in the design process and must be included in the concept and application stage submissions.**

*The amount and location of vehicle parking has a fundamental bearing on the density, design and quality of a scheme. Parking can affect street widths, block sizes and plot sizes as well as the character of streets and spaces. It is therefore essential to know from the outset how much parking is to be accommodated and where.*

- With reference to published parking standards and discussions with the Local Planning Authority, the parking strategy should set out the following.
  - Amount of resident parking
  - Amount of visitor parking
  - Amount of accessible parking
  - Amount of service parking as necessary for non-residential uses
  - Location of parking, distinguishing between
    - on-street (parallel, angled, 90 degree)
    - mews (see Section S2.5 and 3B)
    - off-street shared
    - off-street individual (on plot)
  - Ensure that accessible parking is located near to the home and neighbourhood facilities.
  - The layout and design of parking should seek to minimise the opportunity for ‘anti-social’ or unsanctioned parking both by the provision of spaces in the right places and by physical obstruction as necessary. Such measures should not contribute to visual clutter.
- See Sections 4B.1.1.14, 4B.2.1.18 and *Inclusive Mobility* for details of accessible parking spaces.

### Density, building type and parking

Typical mix of types	Likely parking solutions	Rule-of-thumb density
Detached, semi, terraced	On-street, off-street individual	Up to 35 dph
Semi, terraced, mews, flats	On-street, off-street individual and shared, mews	35 to 55 dph
Terraced, flats, mews	On-street, off-street shared, mews, structured	Over 55 dph

*The table above provides a general rule-of-thumb guide to the relationship between building type, parking type and density that can form the basis of successful, high quality schemes. Unless requirements for parking and/or garden and amenity space are reduced significantly, densities over 55 dwellings per hectare generally require more specialised parking solutions.*

*For indications for on-street parking see Section S2.5 and Section 4B.2.1.18*

*For further detail for off-street parking see Section B1.6 and Section 4B.1.1.14*

**Building for Life criteria**

- 1** Does the development provide (or is it close to) community facilities, such as a school, parks, play areas, shops, pubs or cafés?
- 6** Is the design specific to the scheme (the location and its character)?
- 14** Does the scheme integrate with existing streets, paths and surrounding development?

**Core principles:** integrated, equitable, efficient

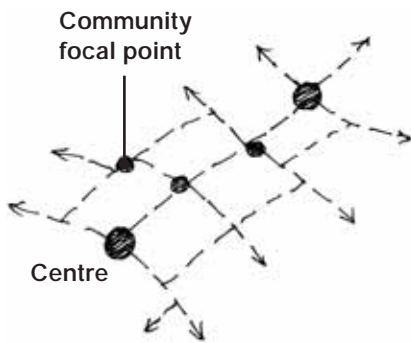

*Centres and community focal points are best located where streets come together*

**Building for Life criteria**

- 6** Is the design specific to the scheme (the location and its character)?
- 14** Does the scheme integrate with existing streets, paths and surrounding development?

**Core principles:** integrated, equitable, efficient

## N5.6 Streets and centres

**Create direct and convenient connections to existing and new centres and community focal points.**

- The street pattern should establish direct and convenient access to facilities in the established built up area, such as schools, public transport stops, shops and other community focal points.
- The routes that connect a site to neighbouring facilities should be of a higher order than other streets, which is to say a more active, main route, and should be designed accordingly.
- These routes should be the most attractive to pedestrians and cyclists.
- For larger developments that involve creation of a new centre with services and facilities, the location of the centre and arrangement of streets must be based on the neighbourhood and movement elements of the appraisal.

**Community focal points should be located on higher order streets.**

**For larger developments that involve creation of a new centre, the location of the centre and arrangement of streets must be based on the neighbourhood and movement appraisals.**

**Centres should be located to extend and complement the existing pattern of centres. Centres should be integrated within the street network and located on or near a principal street or higher order route.**

- As far as possible streets should be arranged to converge on centres making direct, easily walkable connections to them. Development should also seek to create alternative routes to centres, each with a distinct character.

## N5.7 Connected streets

**The design of the street pattern should form a connected network of streets. There should be enough connections with surrounding streets and neighbourhoods and within new development to create a layout that is walkable, offers direct connections, choice and flexibility.**

**As far as possible, new streets should be connected at both ends to form a through street. A cul-de-sac should only be used if the following conditions apply:**

- It is the only appropriate design solution
- It makes a positive contribution to the character and vitality of the neighbourhood
- It maintains pedestrian permeability and acceptable walking distances
- It achieves acceptable levels of safety and security
- It is short and straight.

**Proposals should allow for the future expansion of the movement network to enable future phases of development to be fully integrated.**

- A good level of walkability is provided by distances between junctions of 60 to 90 metres on the short side and 90 to 180 metres on the long side.

*Providing connected streets serves to:*

- Create a legible and permeable pattern of streets
- Minimise walking distances between the site and facilities in surrounding neighbourhoods



A pattern of connected streets (in red) makes walking easier



Loops and cul-de-sacs (in magenta, violet and blue) create longer routes for many journeys making walking less attractive

- Integrate new residents within established neighbourhoods, creating more cohesive communities
- Provide new connections through an area, not just to and from the site, which would benefit the wider community
- Lead to a more even spread of motor traffic throughout the area and avoid the need for single purpose distributor roads without frontage development.

### Issues with through routes

Achieving a well connected layout essentially means extending the highway network into and through the site. Allowing movement through the site raises two important issues:

- Managing any adverse impacts of motor vehicle traffic, in particular speed
  - Limiting or discouraging extraneous traffic.
- The network layout should balance the benefits of a connected street pattern with the aims of reducing speed and extraneous traffic.

### Speed reduction

- The preferred solution for deterring through traffic is to restrict vehicle speeds in the area rather than designing impermeable layouts.

Speed reduction thus helps to deal with both issues.

A variety of speed reduction techniques are discussed in Section 4B.1.2 and 4B.4.

### Non-car links

- Street patterns with selected non-car links may be appropriate in some circumstances. In such cases the non-car link should have the size and appearance of an ordinary street and enable an all-purpose link to be provided at some point in the future. A simple bollard or other vehicle barrier on one arm of a junction is an effective solution.
- If pedestrian/cycle only links extend beyond a simple vehicle barrier they should be short, wide, straight and well overlooked to avoid creating security problems.
- The space should be sufficient to avoid conflicts between cyclists and pedestrians. The aim should be to allow flexibility and not build in impermeability.

Street patterns with non-car links can be desirable to promote pedestrian, cycle or public transport and to help discourage extraneous through traffic.

Other reasons for providing non-car links include:

- Encouraging walking and cycling
- Avoiding conflicts between different modes

For further guidance on junction spacing and design refer to Section 4B.3.



This non-car link in Bessacar is the full width of the street and maintains good surveillance of a the space, creating a community focal point

**Building for Life criteria**

- 6** Is the design specific to the scheme?
- 7** Does the scheme exploit existing buildings, landscape or topography?
- 8** Does the scheme feel like a place with distinctive character?
- 9** Do the buildings and layout make it easy to find your way around?
- 10** Are streets defined by a well-structured building layout?

**Core principles:** integrated, vital, local

## N6 Townscape, topography and views

### N6.1 Townscape

The design of all new development must be based on an appraisal of the townscape of the site and surrounding area and their relation to topography.

All new development must be designed as a considered response to topography and townscape and should use townscape elements to create a place that is understandable, memorable and visually interesting.

- The appraisal and designs must be considered and evaluated from the viewpoint of the users. The primary point of view should be that of a person resting or moving at a slow walking pace.
- Townscape elements (see Glossary) include, amongst others:
  - Landmarks
  - Focal points or nodes
  - Gateways
  - Edges
  - Enclosure
  - Skyline
  - Views.
- These and other features may be considered as heritage assets. Their historical dimension and significance need to be taken into account in the appraisal.
- The purpose of identifying or including townscape elements is to highlight, emphasise or pick out parts of the development and give them an identity that also contributes to the identity of the wider area.
- Townscape elements should be used throughout the proposal but should be focused on the public realm.
- As far as possible, proposals should be designed to incorporate retained existing features as townscape elements.
- Combine townscape elements to highlight important locations and topographic features and reinforce centres and community focal points, the landscape framework and street hierarchy.



*The combination of topography, well defined street front and tree planting give this part of Crookes in Sheffield a distinct identity*

## N6.2 Topography

**Streets should be aligned to work with and express the topography.**

*Landform is one of the most enduring aspects of a place and the relationship between development and topography is therefore one of the most important in achieving a sense of local distinctiveness. The main principle underlying the characteristic arrangements found by examining existing settlements is 'walkability'. The routes that are most expressive of place tend to follow the lines that are easiest to walk. Those same routes also tend to be the easiest to construct and make the most of views out. One solution helps to achieve a number of core principles.*

- Align routes:
  - parallel to contours (allowing sufficient slope for drainage)
  - at right angles to contours
- Routes that run diagonally across contours must be justified with reference to a specific purpose such as:
  - To create a direct connection to a centre or other main destination
  - To accommodate an existing natural or built feature
  - To accommodate steeper slopes.
- Buildings should be stepped to accommodate slopes and the resulting roofscape should follow the topography.
- In general it is preferable to use buildings to accentuate topography rather than counter or 'flatten' it.

*Stepping buildings down the slope allows greater access to views from buildings. Attention should also be paid to the alignment of streets with respect to topography to take advantage of longer distance views. Where possible, streets should be aligned to highlight particular landmarks or panoramic views.*

- Where necessary for access, use gentle slopes and alternative routes to any steps that are introduced. Ensure there are pause points on ramps and steps.

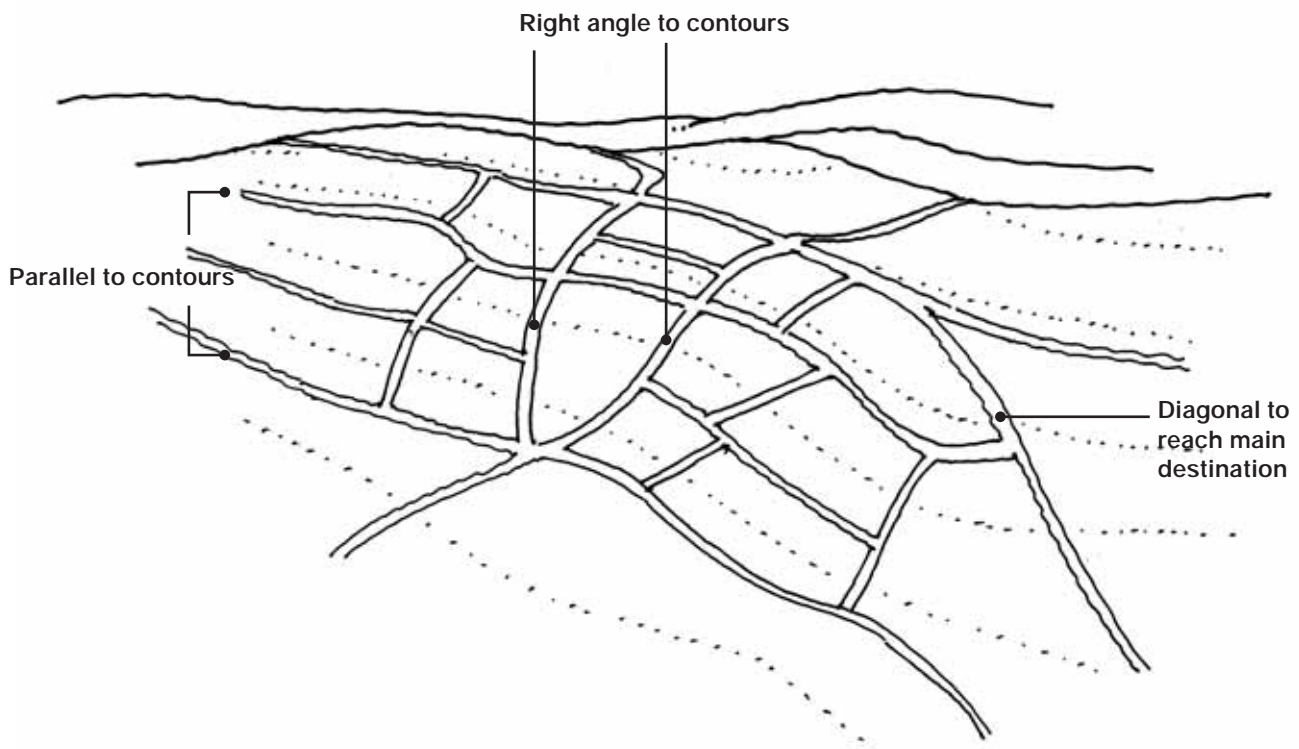

*When routes follow the topography, they blend into the landscape and make the form of the land more visible*

View over roofs

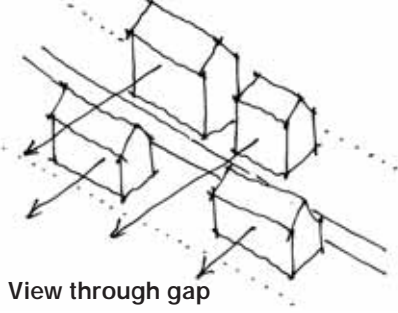

View through gap

Keeping buildings parallel to contours helps to take advantage of views



Aligning routes at right angles to contours allows for good views from hill tops and down hills

## N6.3 Views

Views in and out of a site should be a key consideration in the layout of proposals.

- There are three principal ways in which views out from a site can inform and be integrated into a new development.
  - Align streets to frame the view seen along the line of the street
  - Place open spaces or gaps to allow a view out between buildings
  - Take advantage of slopes to allow views over the tops of buildings (either from the street or from inside buildings)
- As far as possible ensure views of landmarks are well framed to avoid partial or cut-off views.
- The same methods can be employed using buildings and planting to avoid negative views.
- Similarly, the same three opportunities need to be taken into account when considering views into the site. The proposal should be designed to ensure views in are well framed and present a positive aspect that is well composed and appropriate as a public front.

### Termination of views

- Views down a street or through an opening within a site should end with a well considered composition. Vistas down streets should be to open space, a landmark, planting, a building or composition of buildings. Where possible end views with important, positive features outside the site.
- The longer the vista, the more important the object stopping the view should be.
- Terminate the view down longer streets with larger stature trees and/or larger stature buildings ideally those with a public function.
- Views that include deciduous planting should be assessed on the basis of the winter view.
- Use intermediate landmarks or markers along longer streets.
- Place landmarks or marker buildings where three or more views end in the same location.
- Views down streets long or short must not be terminated by garages, parking, storage, service entrances, backs of buildings, sub-stations or other utility equipment.



Like this case in North Aston, Rotherham, the slope of a site can be used to take advantage of distant views

**Building for Life criteria**

- 6** Is the design specific to the scheme?
- 7** Does the scheme exploit existing buildings, landscape or topography?
- 8** Does the scheme feel like a place with distinctive character?
- 9** Do the buildings and layout make it easy to find your way around?
- 10** Are streets defined by a well-structured building layout?

**Core principles:** integrated, vital, local

## N7 The public realm, open space network and legibility

**Townscape, together with the public open spaces (N1.5) landscape framework (N4.2), street pattern and route hierarchy (N5.1) create the wider public realm and open space network.**

**All schemes should seek to co-ordinate the landscape framework, street pattern, route hierarchy and townscape to create a coherent public realm and open space network. All the elements should work together to create the sense of a larger whole and make places more memorable and easy for people to find their way around ('legible').**

*Places are more legible and memorable when the different elements reinforce each other to create distinct combinations specific to their location and context.*

*Legibility is also enhanced by a well defined public realm with a sense of continuity. The combination of connected streets (N5.7 above) and spatial enclosure (S1.7 below) help to create that sense of continuity. The result, in terms of the form of development, is the formation of perimeter blocks (B1.2 below).*

- Further aspects that should be taken into account in seeking to create a legible layout include:
  - Views and vistas
  - A coherent sequence of spaces (serial vision)
  - Visual richness
  - Building height, enclosure and variation
  - Public art
  - Trees and other landscape features
- A concept plan for the public realm and open space network should be submitted as part of the Design and Access Statement. The concept plan should show how the landscape framework, street pattern, route hierarchy and townscape combine to make the proposed development memorable and legible.
- The concept plan should show the areas intended to be adopted as public highway or public open space, the general type and extent of materials to be used, the location of street trees, planting, the street lighting layout and general location of service corridors (see S1.3 below)

# 3.3

## Streets

**Building for Life criteria**

- 6** Is the design specific to the scheme (the location and its character)?
- 8** Does the scheme feel like a place with distinctive character?
- 9** Do the buildings and layout make it easy to find your way around?
- 10** Are streets defined by a well-structured building layout?
- 11** Does the building layout take priority over the streets and car parking, so that the highways do not dominate?
- 13** Are the streets pedestrian, cycle and vehicle friendly?
- 15** Are public spaces and pedestrian routes overlooked and do they feel safe?
- 16** Is public space well designed and does it have suitable management arrangements in place?

**Core principles:** vital, equitable, local

## S1 The street as a whole

**All development should create or form part of a street.**

*If the heart of a neighbourhood is the centre, the main body of the neighbourhood is made up of the surrounding residential streets.*

*The defining feature of the street is the arrangement of plots and buildings facing or fronting onto the public highway and defining distinct areas of public and private space. Functionally, the public realm is for the common activities of movement and public interaction and the private realm for occupation.*

*This definition underlines the fact that a street is not just the carriageway. To function properly the public highway and the buildings in their plots either side need to work together. In this view, an individual street is made up of both the public highway and the buildings in their plots either side.*

*As noted in Manual for Streets, 'increased consideration should be given to the 'place' function of streets. Streets should no longer be designed by assuming 'place' to be automatically subservient to 'movement'. Both should be considered in combination, with their relative importance depending on the street's function within a network.*

*The elements making up the street should work as an integrated whole. On the one hand, the public highway should act and appear as a shared extension of the plots either side and, on the other hand, the plots together should create the 'walls' or boundaries of a clearly defined street space.*

*Again, as noted in Manual for Streets, streets should fit into the context of significant buildings, public spaces, important views, topography, sunlight and microclimate.*

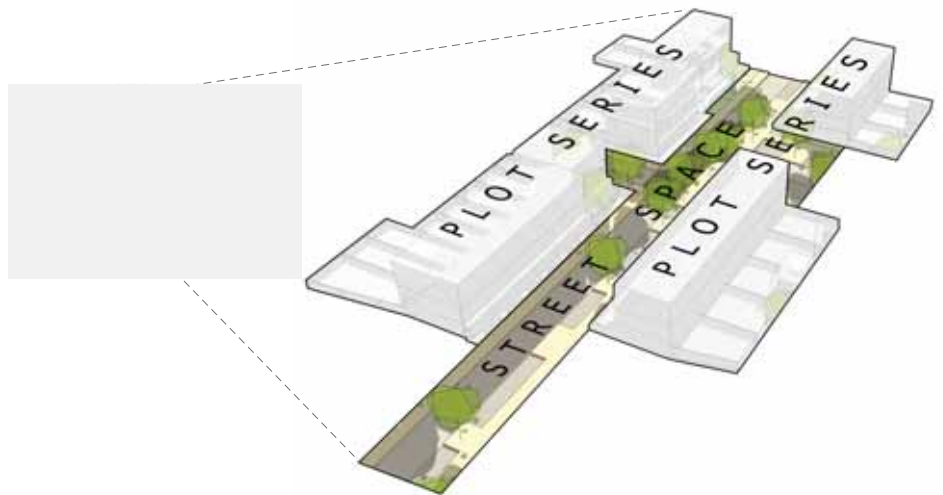

*The street as a whole is made up of the street space with a row or series of plots either side*

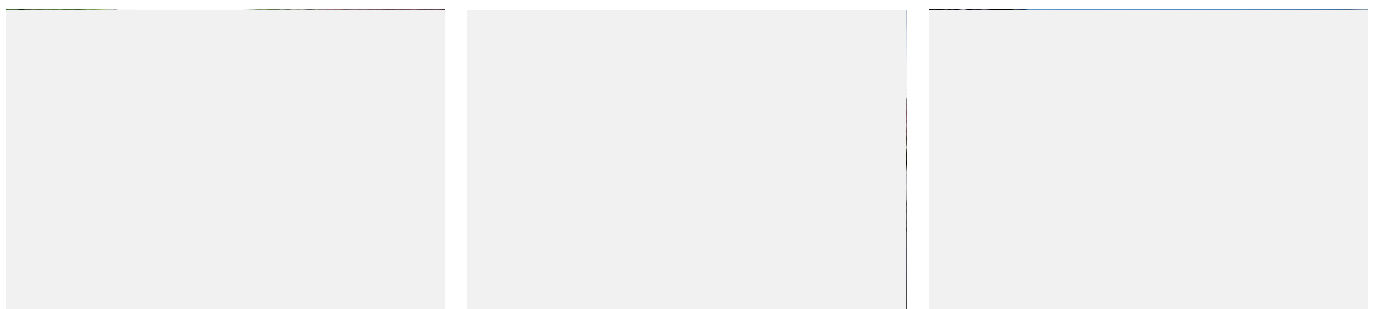

*The street is the common element of all neighbourhoods but each street should have its own character and identity*



A street in Worsborough Bridge, Barnsley clearly defined by the front of the building



This end terrace in Crookes, Sheffield turns the corner with a door and windows on the gable end

## S1.1 Fronts and backs

All streets should be defined by the fronts of plots with buildings oriented to face the public highway, space or private street space. Sides and backs should be set against adjacent sides or backs.

Buildings should be positioned to create an active frontage, with doors and windows overlooking the public highway, space or private street space.

Where the development site abuts an existing public highway, the new development should where possible front (and complete) the existing street.

Mews (see Section S1.5) are considered as streets and must have at least two dwellings fronting the street space.

- The principal access of a building should face the main public highway (as opposed to a back, secondary or service access).
- Access to buildings along the street should be as frequent and numerous as possible to create an active frontage. Long stretches of street without an access to a building will not be acceptable.
- Potential conflicts between achieving active frontages and achieving good solar or wind orientation or accommodating steeper slopes should be addressed through the internal layout of the building. The internal layout should be adjusted to achieve a balance between the aims.

## S1.2 Streets as places

The design of streets should accommodate a range of different modes of movement and contribute to creating community ties by providing pleasant and welcoming places where informal interaction between people is encouraged.

*Streets have a social and functional role within a neighbourhood as well as a role as part of the highway network.*

- Streets should be designed as places where people come and go (by all modes of transport), meet and interact.

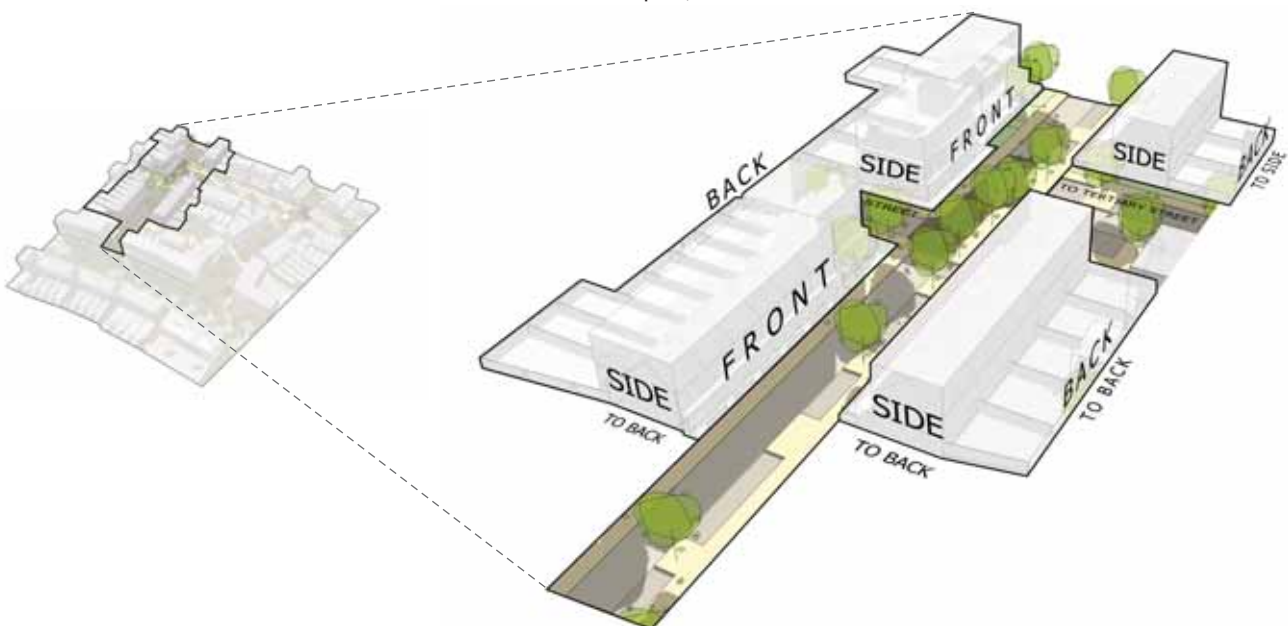

*The fronts and backs of the whole street determine how it works as a space and how it fits together with others to create a legible neighbourhood*

## S1.3 Main components of the street

The applicant must demonstrate at the concept and application stages that there is sufficient space to accommodate the key proposed components of the street and how they are arranged to achieve the core principles and design objectives.

All proposals must include cross-sections for key streets from building frontage to building frontage, including the private spaces in front of buildings, to demonstrate how the street will look, feel and function as places where people move, meet and interact.

- The components that need to be taken into account include:
  - Plots and buildings
    - including main and secondary buildings, set-backs, building lines, external spaces, parking and boundaries
  - The street space
    - Footway
    - Space requirements for cycling
    - Verge, median or island
    - Street trees
    - On-street parking (including orientation)
    - Carriageway
    - Speed reduction measures
    - Sustainable drainage systems (SuDS)
    - Street lighting
    - Street furniture
    - Utilities – current needs and future requirements
    - Surface materials.



*Street sections are the most effective way to illustrate the components of the street and their space requirements*



A principal street with a conventional section in Doncaster



A local street in Old Town, Barnsley, with a conventional section



An informal shared space in Wentworth, Rotherham



A level surface shared space in a mews

## S1.4 Management and maintenance

Management and maintenance of the public highway as well as private street spaces must be considered from the outset and general principles agreed with the adopting authority at the concept stage.

A management body or organisation must be identified in advance of submission to take responsibility for maintaining any elements not adopted as part of the public highway.

See Section 4J on adoptions for further detail.

## S1.5 General kinds of street

For the purposes of this guide, the definition and identification of different types of street is based not simply on the level of traffic flow but the position and role of the street within the street pattern, the buildings and activities either side of the street space and the importance of the street to the local community. The main generic types of street are:

- Principal streets
- Local streets, which are divided into
  - Conventional Streets
  - Shared Space Streets

Mews or mews courts and Home Zones would typically be Shared Space Streets. These lower level streets may in some cases remain unadopted, forming shared private spaces, but should still follow the principles of good street design.

### Principal streets

Principal streets sit at the upper end of the hierarchy because they connect places and destinations that have a high order of importance, such as main and district shopping centres. Their associated plots and buildings tend to accommodate a range of uses.

### Local streets

Local streets extend the network out from the principal streets. The more directly connected a local street is to a principal street, the higher it sits in the hierarchy.

### Shared Space, Level Surface and Home Zones

These types of street are strictly different kinds of *street space* and are dealt with in more detail in Section S3.

### Mews and mews courts

A mews or mews court is a specific type of Shared Space Street. It is a street in itself giving access to buildings (dwellings) but must be ancillary or subsidiary to at least one local or principal street. A mews therefore sits at the lower end of the hierarchy. A principal role of a mews or mews court is to accommodate some or all of the parking of its associated local or principal street within mews buildings as well as on the surface of the street. A mews must be immediately adjacent to its associated street and visually subservient to it.

## S1.6 Character and variation

The character of new streets should not be uniform but should vary as part of a hierarchy, depending on their location in order to integrate development into the locality, to retain local distinctiveness and create vibrant, legible and memorable places.

The physical design and character of streets should reflect and reinforce the hierarchy of routes.

- The specific character of a street should be an appropriate response to:
  - Its position in the route hierarchy in the area (including traffic volume)
  - Proximity to existing and proposed centres and focal points
  - Topography
  - Views
  - Green infrastructure and local landscape features
  - Character areas
- Streets at different levels in the street hierarchy (higher or lower order) should have different designs and character in order to make places easy to understand and get around.
- Where possible new development should work to improve the legibility and perception of the hierarchy.

*Variation in streets is extremely important for legibility. When you come to a junction, the character of the different streets should tell you, for example, whether turning or going straight ahead will take you closer or further away from a centre. The internal composition of the street should help to tell you where you are.*

- The unit of character should be the street with both sides similar or complementary unless a single-sided or split character street is an important feature of the specific location.
- The main aspects of the street that should be varied to create a hierarchy include:
  - Non-residential uses
  - Width (frontage to frontage and/or building line to building line)
  - Building height, materials and details
  - Elements within the highway such as carriageway, footway, trees and verges
  - Surface treatment



A conventional, local street is suited to middle levels in a hierarchy such as secondary and tertiary streets



Shared and level surfaces are suited to the lower levels of traffic on mews and lanes



The subtle, sinuous curve of this street in Cawthorne fits the topography and creates interest and diversity. Tight, arbitrary curves look less natural

- The variation between streets must be clearly perceptible on the ground
- Streets of a higher order should generally be longer and straighter.

Because the aim in designing the movement structure is to provide direct connections between centres of activity, those routes tend to be straighter and longer. The straightness and length of a street is also a strong clue that it leads to a centre or destination.

Streets that have a higher level of activity and a higher link status should be designed to be longer and straighter. This will improve legibility and way finding for people. Care will need to be taken, however, to limit traffic speeds. See Sections S2.3 and Sections 4B.1.2 and 4B.4 for the range of measures that can be used for speed reduction.

- Arbitrary curves should be avoided.







Curves are best introduced as a response to existing features such as topography and in association with buildings and other features as part of a coordinated design. Designs should avoid the contrived introduction of arbitrary curves.

Straighter or slightly curved roads have the following advantages:

- Good legibility and orientation by increasing forward visibility
- Efficient use of land
- Simpler and more effective street blocks
- Simpler and more effective provision of utilities

When streets become straighter care will need to be taken to keep traffic speeds to acceptable values. Further guidance on speed restraint is set out in Sections S2.3 and Sections 4B.1.2 and 4B.4.

ROUTE HIERARCHY

- Primary, higher order route 
- Secondary, higher order route 
- Lower order routes 
- Vehicular access 
- Public footpath 
- Private footpath 



In most villages and towns, main routes are longer, often with a 'sinuous' alignment

Mapping © Crown copyright. All rights reserved Licence Number 100018816, 2010



The trees within this wide street space (1:6) create a strong sense of enclosure



This street has a ratio of about 1:2 and gives a comfortable degree of enclosure



The ratio for this street is about 1:1.5, and gives an intimate feel suited to shorter lanes and links

## S1.7 Spatial enclosure

Street spaces should have an appropriate sense of spatial enclosure suited to their location and role.

*Spatial enclosure contributes to the comfort and positive character of streets. Adequate spatial enclosure is one of the most effective ways of ensuring the street is easy to find your way around and not dominated by the highway and cars.*

- Spatial enclosure is principally provided by:
  - Buildings
  - Vertical boundary features
  - Street trees
  - Trees and vegetation within plots.
- The predominant means of spatial enclosure should suit the location and character of the area: in more urban areas, buildings and walls are appropriate and in rural areas planting, walls and fencing.
- Widths and height to width ratios (building front to building front) should be determined by:
  - Characteristics of streets in the locality
  - Type and level of activity
  - Daylighting of buildings.

### Height to width ratios

- Height to width ratios of between 1:2 and 1:4 provide good spatial enclosure. Ratios less than 1:4 (e.g. 1:5) will usually need street trees to create an adequate sense of enclosure. Higher ratios (e.g. 1:1) may be appropriate in central urban areas with higher buildings and proportionately wider streets.
- Where possible development should help to improve poorly enclosed streets.

### Front-to-front dimensions

- The dimension across streets, measured from building front to building front (or side), should vary to emphasise the street hierarchy. The width of the street space should be proportionate to the order of the street in the hierarchy. Principal and higher order streets should be wider. Lower order streets should not normally be less than 12 metres, measured building front to building front (or side).
- Narrower and minimum widths will only be acceptable as part of a larger area with a significant proportion of wider streets (existing or proposed).
- Streets at the narrower end of the range must be connected directly to a wider, higher order street and should have sufficiently long or open views along the street to avoid an overly cramped or claustrophobic environment. Views should end in a wider street or an open space.
- The acceptability of narrower streets will also depend on other design considerations such as the arrangement of windows onto the street for reasons of privacy, the detailing of the building and the detailing of the street space.

*See Section B1.3 for further information on separation distances.*

## S1.8 Defining the public and private realms

Streets should have a clear definition between the public and private realms.

**The boundary or means of enclosure of private land must be appropriate to the character of the area and the location and visibility of the boundary.**

*Within the street, the boundary between the public and private realms should be clearly defined. As set out in Section S1.1, the core principle is to use the frontage line in parallel with the building to mark and create the boundary.*

- The front plot boundary line or frontage line should be occupied by a building or a vertical boundary feature or, in some circumstances, marked by a change in material. Front boundaries walls or fences should not be too high and blank.
- External private space between the frontage line and building such as front gardens or shared private gardens is best if defined by a physical boundary or 'means of enclosure'.
- Layouts should avoid placing side or back boundaries in prominent locations.
- Side or back boundaries that face street spaces or footpaths or are otherwise visually prominent should contribute positively to the character of the development (see B1.2).
- Boundaries with the open countryside should be buffered with planting and avoid a blank, flat appearance.



*The picket fence defining a shared open space in Wentworth, Rotherham is suited to the more rural location*



*Brick walls with a distinctive coping detail in Doncaster both define the public realm and contribute to the character of the area*



*The low wall and small set-back in Dodworth, Barnsley provide an effective transition while maintaining enclosure*



*The stone wall and hedge (left) and building (right) in Cawthorne both clearly define the public realm in their very different ways*

## S1.9 Creating a sense of integration

The design of streets should create a clear sense of integration in which each element contributes to the perception of the street as a whole. Integration is not uniformity and allows for variation to create interest.

*Integration of a street into its context is principally a matter of making connections to the network and sharing physical characteristics with other streets in the locality where compatible with inclusive design. It is just as important to achieve integration of the components that make up an individual street.*

- In order to achieve integration within the street, each component, including the buildings, boundary features, footways, verges, trees kerbs and carriageway, must work together to create a sense of a larger whole. These elements should not appear as isolated, unrelated fragments.

### Size and continuity

*Longer streets with continuity of elements along the street tend to have a stronger sense of integration. Very short streets with closed views or streets with too many sharp bends create a greater sense of fragmentation and can be very disorienting.*

- As far as possible streets should have a minimum run of five houses or the equivalent length on both sides. There should be a greater degree of similarity and continuity of elements on shorter streets.

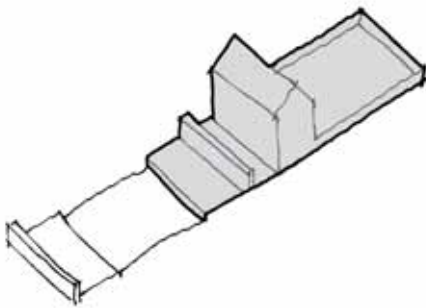

The 'extended plot' includes the footway

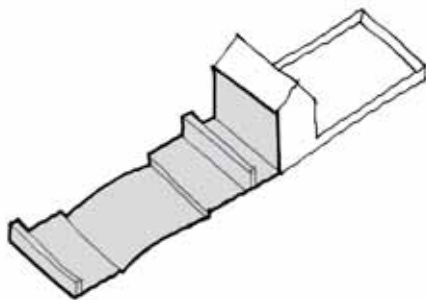

The 'extended street' includes the frontage

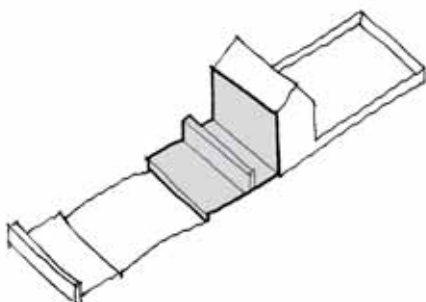

The footway and frontage are common to both and tie them together

### Similarity and reinforcement of orientation

*Visual integration of streets is achieved to a large extent by orienting the components along the same or similar alignment while still allowing for gradual variation or the exceptional contrast. In traditional streets, the following elements tend to run more or less in parallel:*

- Ridge line
- Eaves line
- Façade
- Boundary feature
- Footway/ pedestrian space
- Verge
- Kerb.

*The sense of integration comes from both the roughly parallel arrangement and the relatively straight line of each element. Significant and frequent differences in orientation of buildings visually fragment the street.*

- A sufficient number of elements in the street should be aligned more or less parallel and have relatively continuous lines to give the street a sense of integration. Gradual variation in the width of elements such as carriageways and footways can be used to create interest and in response to specific features or constraints. Similarly, exceptional contrasts can help to reinforce the wider sense of integration.

### Interlocking and shared elements

*Another way a street gains a sense of integration is when the components are 'interlocked' by a common element. Plot boundaries and footways, for example, lie at the boundary between plots and street spaces and read as an element of both. They appear as an extension of the series of plots on the one hand and as an integral part of the public highway on the other.*

- As far as possible, features that work as a common, shared element between main components should be included to achieve a sense of integration within the street. The footway or pedestrian space should be used as the principal shared element binding together plots and street spaces.

**Building for Life criteria**

**13** Are the streets pedestrian, cycle and vehicle friendly?

**16** Is public space well designed and does it have suitable management arrangements in place?

**Core principles:** vital, equitable

## S2 Street spaces and the public realm

Street spaces should be designed as a common resource – the public realm – shared by all users with some variation depending on the priority placed on particular users.

The physical design and character of street spaces should reflect and reinforce the wider pattern and hierarchy of streets.

The pattern of street spaces and public open spaces should be co-ordinated with and reinforce the landscape framework.

The choice of surface materials, planting and street furniture has a large part to play in achieving a sense of place.

The design of the street space must be a response to:

- The specific position of the street in the local hierarchy and network
- Proximity to centres and destinations
- Density of development
- Level of activity within the space
- Speed and volume of vehicles
- Character and townscape.

The detailed design of streets must ensure they are comfortable and accessible for all users in terms of the following criteria:

- A comfortable microclimate
- Adequate space for its location and level of activity
- Footways or physically demarcated pedestrian areas to provide a protected space for pedestrians
- Focal points as resting and meeting places at regular intervals
- Adequate and inclusively designed street furniture.

*Of particular importance is the inclusion of footways or physically demarcated areas for disabled people and other users who are unable or unwilling to negotiate priority with vehicles.*

### S2.1 Street space types

Different types of street space should be used to suit the location, position and priority of the user.

- In terms accommodating different users of the street space, streets can be distinguished as:
  - Conventional
  - Shared Space Streets with a physically demarcated protected zone for pedestrians
  - Shared Space Streets with a level surface, only where vehicle flows are very low.

#### Conventional streets

- Conventional street designs are suitable in all situations but are particularly appropriate for higher order streets.

*Conventional streets have a carriageway and footway, separated by a kerb of 75-100mm height or greater and a distinct difference in the material of the carriageway and footways.*



A conventional street with a footway and carriageway



A shared space street with areas identified for pedestrians (other features may be necessary in some situations to define the protected zone)



A level surface street with the plot boundary providing a distinct, continuous edge



A Home Zone, clearly marked out by the entry sign

### Shared Space Streets with a Protected Zone

- Shared Space Streets with a Protected Zone are limited to more lightly-trafficked routes within predominantly residential areas.

*Shared Space Streets are those where the separation between carriageway and footway is reduced and the difference between the vehicle track, where vehicles are permitted, and the area set aside for pedestrians is less physically distinct than the standard footway and carriageway separated by a kerb.*

*Technical guidance on the criteria and design speed for the use of Shared Space Streets is given in Section 4B.1.1.*

### Level Surface Streets

- Level surface streets are appropriate for relatively short stretches in locations with low to very low vehicle flows and speeds.

*Level Surface Streets are a kind of shared space where very low vehicle speeds mean the vertical differentiation may be removed to provide a single shared surface.*

*Such locations may be at the very lowest end of the hierarchy (lowest order) such as mews and Home Zones or lanes serving only a very small number of properties. Appropriate locations might also be highly controlled areas within a centre or focal point.*

- All Shared Space and Level Surface Streets should be designed to encourage drivers to informally give priority to pedestrians.
- In Shared Space Streets with a Protected Zone, low kerbs are a recommended feature as they are continuous and aid navigation for people with a visual impairment. A range of other features can be used to supplement and support the function of the protected space, such as:
  - Bollards
  - Planters
  - Seats
  - Trees
  - Light columns.

### Home Zones

*Home Zones are streets that are designed to be used by the community for a range of activities, as well as places for vehicles. Both Shared Space and Level Surface Streets can also be designated as Home Zones. Designation involves the following further requirements.*

- The provision of features to encourage the community to use the street, such as seating and informal play sculptures
- Home Zone signage at the entrance to the street(s)
- Designation under the Transport Act (2000)

*For further guidance relating to the design of individual streets, please refer to Section S1, above, and Section 4B1.1.*

## S2.2 Continuous access

As part of achieving the aims of inclusive design (see A2), all schemes must be tested for continuous access to the nearest centre, transport stops and other facilities with potential obstacles identified and mitigation proposed as necessary.

*The idea of continuous access is to provide pedestrian routes to key facilities with as few interruptions for as many different users as possible. The safe and continuous route should be obvious from the design without the need for signage.*

- Routes for continuous access should have the following features:
  - Follow desire lines at junctions
  - Clear, unobstructed lines of movement
  - Colour/material designation of protected spaces for pedestrians
  - Buffers between pedestrian space and sources of danger
  - Frequent and safe street crossing points
  - Small kerb radii at junctions
  - Flush kerbs and blister surface tactile paving at crossings
  - Raised crossings and/or formal (Zebra or signal-controlled) at busier streets
  - Markers such as tactile paving at crossings to warn of danger
  - Continuous edges.
- Continuous edges can be created using a number of different features including:
  - Building and boundary walls
  - Change in materials and/or colour
  - Kerbs.

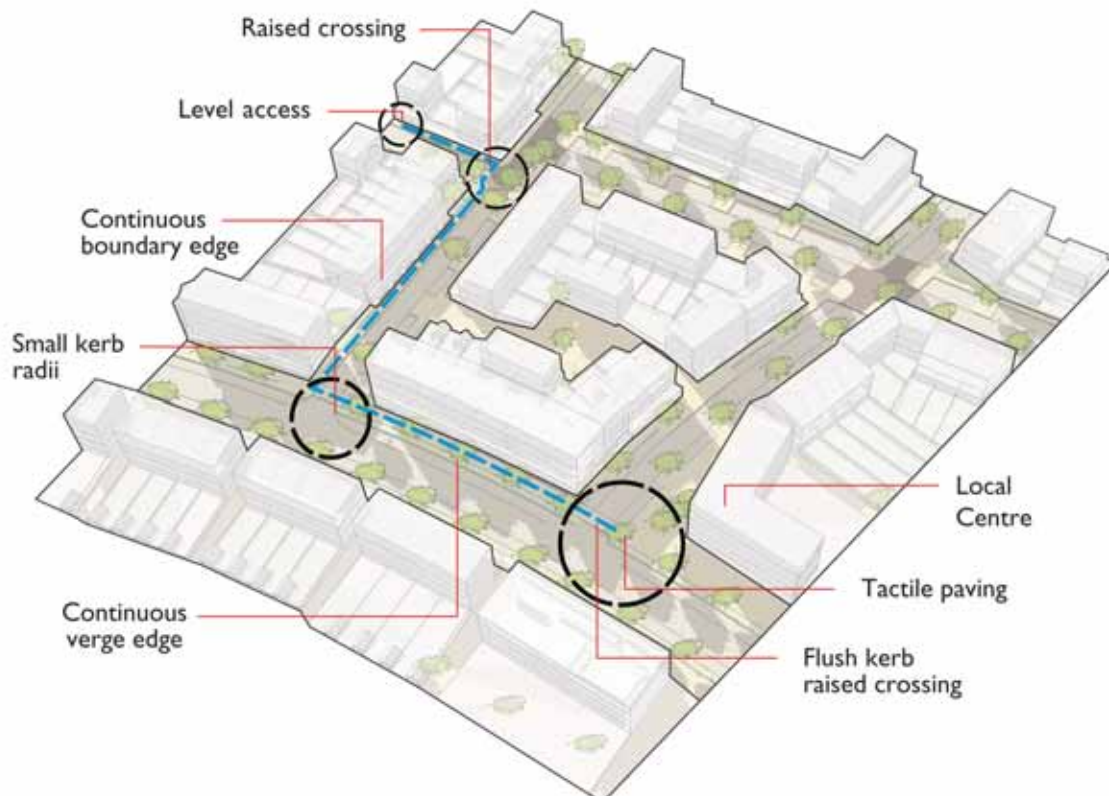

*Continuous access is achieved by combining a number of different elements on the most direct routes*



Footway build-outs can be an effective means of speed reduction on existing streets



A speed reduction strategy could include raised crossings and small kerb radii



The raised table junction in the foreground combined with good enclosure creates a general feel that higher speeds are inappropriate (other features may be necessary in some situations to define the protected zone)

## S2.3 Vehicle speed

All streets should be designed to achieve the appropriate vehicle speeds as set out in Section 4B.1.2 and 4B.4.

Measures for achieving appropriately low vehicle speeds must be part of a deliberate strategy and integral to the street design as a whole.

*Keeping traffic speeds low has the following advantages:*

- Enhanced safety for all road users
- Deterrence of excessive external traffic
- Reduced need for signage
- Reduced corner radii, which accommodates more direct pedestrian routes
- Reduced requirements for visibility splays at junctions allows for greater flexibility in block layout.

*Control of vehicle speed is fundamental to the safety, security and comfort of other users. Excessive speed can also have an adverse effect on the vitality of streets.*

- The speed reduction strategy should involve a number of different measures.
- Individual speed reducing measures should be multi-functional. They should be features that are included for reasons other than merely to restrict vehicle speed, such as pedestrian crossings, and narrowings to accommodate buildings, trees or street furniture.
- Speed control features included as simple add-ons to an already-completed design are unlikely to be successful either functionally or visually.
- Measures that can form part of a speed reduction strategy include:
  - Well enclosed street spaces
  - Active frontages and focal points
  - Integrated design
  - Character and variation
  - Activity within the street space
  - Junctions
  - Pedestrian crossings
  - Varying kerb alignment and width restriction
  - Position of buildings
  - Position of trees and street furniture
- The strategy should include a number of different measures.

*Sections 4B.1.2 and 4B.4 provide further technical guidance on speed control measures on principal and local streets.*

**Building for Life criteria**

- 9** Do the buildings and layout make it easy to find your way around?
- 10** Are streets defined by a well-structured building layout?
- 11** Does the building layout take priority over the streets and car parking, so that the highways do not dominate?

**Core principles:** vital, equitable, efficient



*The images above demonstrate how simple detailing can create places that are calm and comfortable and assume pedestrians have priority*

## S2.4 Flexibility and adaptability

**Streets, open spaces and community focal points should be simple, flexible and adaptable, easy to understand and use and accommodate a range of uses and activities. Designs must integrate the elements within the street space into a clear, coherent whole.**

*The aim in moving away from an approach to street design that uses fixed types is to allow greater flexibility to respond to specific circumstances and create streets that are more specific to their locality. The task of design is thus not the selection of a stock type but choosing from a range of components that can be combined in a variety of ways to achieve a desired character that is best suited to the role and location of the street being designed.*

- An overarching principle for the successful design of streets should be simplicity.
- To fulfil their role within the neighbourhood, streets should:
  - Be fully accessible and comfortable
  - Have active frontages
  - Have a clear definition between the public and private realms
  - Provide opportunities for informal interaction between people at community focal points.
- The street should 'hang together' as a whole with a clear identity.
- To achieve these aims a street must be well considered, uncluttered, uncomplicated and unfussy.

*This does not mean minimum standard, hasty, least-cost design. Neither does simplicity mean single purpose. Designs that are over specific to a single use tend to be more complicated, less flexible and less adaptable. A good simple design provides clearly defined surfaces, spaces and buildings of the right size in the right place and does not need written signs to tell people how to use it. A simple, flexible and adaptable street is fundamentally more sustainable.*

### Pavement and carriageway

**Generally the geometry of street elements should relate more to pedestrian needs and the overall design of the space and its relation to buildings rather than the needs of vehicles.**

**Widths should reflect levels of activity and proximity to centres, public transport routes and stops or other destinations, subject to achieving minimum acceptable widths set out in Section 4B.2**

- Subject to the dimensions set out in Section 4B.2, more active pedestrian routes should have wider footways and more active vehicular routes should have wider carriageways. The two do not necessarily go together.
- Footway and carriageway widths do not have to be constant.
- Variations in width should be made within the bounds of the principles for achieving an integrated design as set out in S1.8 above. General variation in width along the length of a street should be gradual following longer curves or small differences in the angle between kerb and building line.
- More abrupt changes should be associated with specific objects (buildings, trees etc.) to provide a way around the object for pedestrians and/or vehicles.
- Variations in width can be used to allow for focal points, informal parking and to create pinch points to help control speeds.

**Building for Life criteria**

- 11** Does the building layout take priority over the streets and car parking, so that the highways do not dominate?
- 12** Is the car parking well integrated and situated so it supports the street scene?

**Core principles:** vital, equitable, efficient



*On-street parking within a widened carriageway*



*On-street parking bays integrated with tree planting in a shared space street*



*Echelon parking either side of a central reservation providing space for pedestrians and tree planting*

## S2.5 On-street parking

As part of a wider strategy including a range of different types of parking (see Section N5.5), there should be a general presumption in favour of some on-street parking, in particular for visitor parking and to avoid footway parking.

**On-street parking should be designed as an integral part of the street space and used intelligently as part of the street scene. On-street parking must not present a barrier to inclusive access.**

*Parked cars can make a beneficial contribution to the street by providing opportunities for informal social contact, physical and psychological protection for pedestrians on footways or pedestrian spaces and helping with speed management.*

*The English Partnerships document, Car parking - What works where, sets out nine rules for parking that are worth summarising here:*

- *The quality of the street should come first*
- *Use a combination of locations and methods*
- *'Rediscover the street as a beautiful car park'*
- *Maximise activity between the street and buildings*
- *Use on-street and frontage solutions before solutions within the block*
- *Avoid allocating more than half the spaces*
- *Make deliberate use of the three categories of parking: uncontrolled, controlled parking zones, restricted parking zones*
- *Provide cycle parking with all solutions*
- *Follow Secured by Design principles.*

*The range of on-street solutions suggested includes:*

- *Central reservation (although these are often not suitable for disabled people, except in specifically designed shared spaces)*
  - *Right angled*
  - *Angled*
  - *Longitudinal*
  - *Housing square*
  - *Mews.*
- As best practice, accessible parking for disabled visitors should be provided or justification given setting out why it is not possible. Parking spaces must fit around the pattern of pedestrian spaces and desire lines. Runs of continuous parking on local streets must be broken by a 2 metre gap for pedestrians at least every five spaces for longitudinal parking or every 25 to 30 metres for right angled or angled parking. The design must prevent parking on the gap.
  - Large areas of uninterrupted parking will not be acceptable. The choice of how much and which type of on-street parking to include should be based on the position of the street within the network and neighbourhood, its role and envisaged character. Higher levels will be more appropriate toward main centres or within mews and mews courts.
  - Ideally, spaces should be located to allow the keeper to see the vehicle.
  - On-street parking bays should be simple and integrated with other features. They should not be designed as single purpose features and should not be visually dominant when not occupied by cars.
  - On-street parking can be associated with street trees to soften the visual and thermal impact of the parked cars.

### Mews and mews courts

- The above rules apply to mews but parking arrangements within a mews can be more informal, combining different angles depending on the shape of the space. See B1.6 for information on the off-street parking element of a mews.



*SuDS schemes can be an integral part of the street scene that gives it its character*

## S2.6 Sustainable drainage systems

The use of sustainable drainage systems (SuDS) is advocated by the Local Authorities and the water companies where it can be demonstrated SuDS are acceptable in terms of:

- General drainage impact and flooding
- Ground and groundwater conditions
- Interaction with foul sewers
- Rights of discharge
- Long term inspection and maintenance requirements.

In accordance with the Flood and Water Management Act 2010, the plans for all SuDS proposals must be approved by the SuDS Approving Body (the unitary authorities) prior to the start of construction.

It is essential to involve the adopting authorities (land drainage, highway, highway structures and sewage) as early as possible to discuss the acceptability of any proposals. The agreement should determine what features may be acceptable for adoption, who will adopt them, the maintenance plan and the level of commuted sum required.

- See Sections 4C and 4J for more information on what features will be considered for adoption by the Local Authorities and the water companies.
- Planting and SuDS features within the public highway must be an integral part of the overall design.
- The space needed for SuDS features, tree and other planting must be identified at the concept stage and followed through into the application stage.

## S2.7 Street trees and other planting

By default, tree planting of some kind should be included in community focal points, other public open spaces and areas of on-street parking. The absence of tree planting must be justified by the applicant in terms of location, character, physical conditions or technical constraints.

Adequate space must be provided for planting to accommodate full growth, access to light and protection from damage as well as to avoid obstruction of movement and street lighting.

All planting schemes must be supported by a management and maintenance programme that identifies the body responsible for management and maintenance.

*See Section 4G for information relating to street trees.*

*Positive uses for street trees and other planting within the public highway include the following:*

- Improve microclimate and air quality
- Create sense of enclosure in wider streets and spaces
- Provide visual emphasis
- Provide green corridors/habitat links
- Aid biodiversity
- Define boundaries and spaces
- Create gateways
- Provide visual interest and amenity
- Provide visual screen or filter.



*A simple scheme of street trees in the right place, makes a significant contribution to quality and character*



Street trees can be integrated into spaces at different levels from main public open spaces to verges to small pocket planters

### Suitable plant types

- The species of plant must be matched with the character and size of the space in which it will be planted.
- Planting must be coordinated with:
  - Other uses of the street
  - Street lighting
  - Utilities
  - CCTV, where proposed
  - Drainage
  - Building foundations.
- The most versatile and robust plants for urban situations are trees, grass, hedges and shrubs used as linear features such as boundaries and screens.
- Planting schemes must pay attention to accessibility, the character and quality of the street or space as a whole as well as maintenance and safety.
- Planting should not be used as a 'filler' to make up for the poor arrangement of buildings that leave spaces with no identified use. Spaces between buildings should be designed as positive features in themselves.
- Provision for trees should be proportionate to the scale of development and streets or spaces.

## S2.8 Street lighting, street furniture and public art

All new development must be adequately lit.

Street lighting must be an integral part of the overall design of the street space. The space requirements for lamp standards and their associated electrical equipment must be provided for when setting out the pattern of streets and open spaces at the concept stage.

Lighting and planting schemes must be designed together to ensure that street trees do not reduce the effectiveness of streetlights.

The location of lighting equipment must not cause obstruction or visual clutter. The size and scale of street lighting must be suited to the scale of development. Street lighting will be normally be adopted as part of the public highway.

*Good lighting is essential in creating a secure and comfortable street environment.*

*Lamp standards can form a positive element in the streetscape by reinforcing the line of the street, acting as a part of a protective separator or marking the entrance to an area.*

- Lighting should be part of the 'frame' of the street scene rather than the focus of attention and should not interfere with views to key features or landmarks.
- In general, the height of lighting columns should not be greater than the predominant eaves height of buildings defining the street.
- Lighting levels should be gauged to correspond to the street hierarchy.
- Where possible use building mounted lighting to help keep the public realm simple and uncluttered.
- Typical details of lighting should be included with detailed and reserved matters applications.
- See Section 2, Concept and Application Stage Checklists, for further detail on information required. See Sections 4E and 4I, *Manual for Streets* Chapter 10 and *Inclusive Mobility* for further details.



### Street Furniture

All new development should have adequate street furniture as an integral part of the design.

The location of street furniture must not cause obstruction or visual clutter.

*The position and specification of street furniture, including lamp standards, street signs, litter bins and benches and seats should leave unobstructed clear routes along desire lines and avoid the creation of street clutter which reduces the visual quality of the street and may obstruct footways. Street furniture should be:*

- Simple
  - Unobtrusive
  - High quality
  - Fit for purpose
  - Coordinated in terms of construction, materials and colour.
- Benches or seats with backs and armrests should be introduced at regular intervals, ideally every 100 metres, to provide opportunities to rest, including at community focal points. This will help ensure that streets are accessible to people of all abilities.
  - As with lighting, street furniture should be part of the 'frame' of the street scene rather than the focus of attention.
  - Minimise the number of different types, colours and materials of street furniture. All items should be distinguishable by colour contrast from the surface against which they are viewed
  - Essential items should be grouped together. Posts should be minimised to avoid obstruction and clutter, with signage as far as possible fixed to buildings or boundary walls or sharing a single post.
  - The materials and construction of street furniture should help to establish the character of the area and so should suit the character of the locality.
  - Traditional materials are more likely to be suited to rural locations and contemporary styles more suited to central urban areas.



### Public art

Where required by policy, identify the opportunity for the inclusion of public art as early as possible in the design process and highlight it in the community involvement process.

The installation of works of art into the public realm can add significantly to its quality and character.

- Integrate the artist or artists into the design team and agree the working relationship from the outset.
- Public art should be located in prominent locations along main routes and ideally as part of community focal points.
- Public art objects or installations must not cause obstruction and should be distinguishable from the surface against which they are viewed.
- Consider the possibility that public art is not an isolated object but an integral aspect of 'ordinary' elements of the public realm such as signage or surfaces, boundary treatments, seating, guarding and handrails.



*Street furniture is best when kept simple so that it becomes part of the frame for the life of the spaces*



*As with street furniture, a simple palette of materials is often the most effective for creating high quality places*

## S2.9 Surface materials

Surface materials must be appropriate to their function within the street space and to the character of the development and wider area.

Surface materials should be one of the key attributes that a development shares with the surrounding area in order to maintain local distinctiveness (unless materials from the surrounding area are viewed by consensus as negative, they do not meet the needs of disabled people or are otherwise unfit for purpose).

All surface materials should be suitable for disabled people. Patterns should avoid creating visual confusion or obscuring main routes or simulating hazards.

- Changes from the local palette should only be toward higher quality materials.
- The range of materials in a given scheme should be kept to a minimum while still creating a degree of visual interest. Patterns should relate to surrounding features.
- Contrast of materials should be used principally to help achieve safe environments and continuous access for pedestrians. Arbitrary contrast and patterns should be avoided.
- The design of large surfaces should include some larger scale patterns to strike a balance between fussiness and monotony.

*Section 3H lists the materials that are acceptable to be used in the design of streets. The use of other material is discouraged.*

## S2.10 Services and utilities

The location of service runs should be identified at an early stage in the design process to ensure coordination with other elements of street design, in particular planting and surface material design.

Use a common service trench in accordance with the National Joint Utilities Group guidance.

Route services to avoid damage to existing and proposed trees.

Surface material design should allow like-for-like replacement and repair that minimises the visual evidence of the repair.

*See Section 3F, Manual for Streets, NJUG Guidance and BS 5837:2005.*

- In order to meet the requirements of this section of the guide it is essential that a conceptual landscape and public realm plan is submitted with the planning application. This should show, as a minimum, the area intended to be adopted by the highway authority, the general type and extent of materials to be used, the location of streets and planting, the conceptual street lighting layout and general location of service corridors.

# 3.4

## Plots, blocks and buildings

**Building for Life criteria**

- 9** Do the buildings and layout make it easy to find your way around?
- 10** Are streets defined by a well-structured building layout?
- 11** Does the building layout take priority over the streets and car parking, so that the highways do not dominate?

**Core principles:** vital, local



*This row of terraced houses in Old Town, Barnsley has a strong identity as a whole*



*Even with detached houses, the continuous building line keeps this street together*



*Short blocks, arbitrary curves and the lack of a continuous building line create a fragmented and confusing street*

## B1 Plot series and streets

The arrangement of plots making up a street must be co-ordinated to create a clear identity for the street as a whole as well as to promote accessibility and legibility, positive character and views.

- The series of plots making up each side of a street should form a coherent whole. The plots should work together so that they read as a single component as well as a series of individual properties.

*The principal binding element of a series of plots is the **frontage line**. Further features that help to bind the plots together into a whole include:*

- *Common building size and roofscape*
- *Continuous building frontage (attached or terraced types)*
- *Common boundary treatment on the frontage line*
- *Different boundary treatments with some features in common such as height or materials*
- ***Alignment** and **set-back** of buildings to form a coherent **building line***
- *Common planting in front gardens*
- *Common building type.*
- Individual plots within a series should have some but by no means all of these features in common. The overriding aim is to provide enough continuity and coherence to allow for variations from one plot to the next without creating a visually fragmented street scene. There must be a balance between variation and continuity.
- A continuous plot series should have a minimum of five plots or 25 metres of active frontage except in a mews or court or in other special circumstances such as conservation areas, plots with listed buildings or as determined through a character appraisal. Gaps for parking or access can be included within the series.
- Buildings within a plot series should maintain the predominant building line (including variations) characteristic of the area. Where there is no clear precedent, buildings should form a continuous building line and have the same orientation and alignment relative to the public highway. Variations should be exceptional and associated with some other feature such as tree planting or a distinct building type. Arbitrary variation of the building line is not acceptable.



*The key elements that bind a street together are the frontage line and building line*

- The shape and size of the whole series and individual plots should vary to suit the position of the series in the street and block and relative to other features such as topography and landscape.
- Staggered or ‘saw tooth’ arrangements of plots to accommodate curves or angles should be avoided.
- Series made up of alternating detached houses and garages which produce a ‘gap toothed’ appearance should be avoided.

**Building for Life criteria**

**7** Does the scheme exploit existing buildings, landscape or topography?

**Core principles:** integrated, local

## B1.1 Plot series and slopes

The arrangement of plots making up a street must respond to topography to promote, maintain or enhance accessibility, local distinctiveness and views.

- Use relatively long, narrow, rectangular blocks (or plot series) with long sides parallel to contours to maximise level access to buildings along the contours.
- For plots fronting onto steeper slopes (greater than 4% or 1:25), buildings should be stepped vertically in units of two (plots or dwellings) or every 10 to 15 metres depending on the slope. The aim is to ensure that access points to buildings are as close to ground level as possible and that the roofscape approximates the slope of the ground.
- Where practical place buildings as close as possible to streets with doors grouped toward the centre at ground level to avoid access steps or ramps. Always provide sufficient space to accommodate level parking and ramps which cannot be designed out.

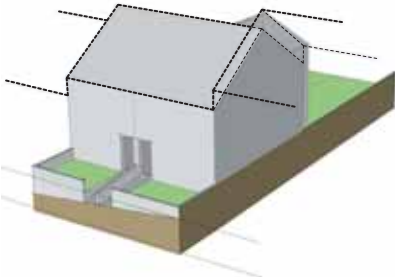

The diagram shows a typical pair that is used to step down the slope relative to the pairs either side (ghosted)



The stepped arrangement, as here in Old Town, Barnsley, means the roof line follows the slope of the ground for a better roofscape



Stepped pairs, near Endcliffe Park, Sheffield, with a shared, central entrance

**Building for Life criteria**

- 6** Is the design specific to the scheme?
- 8** Does the scheme feel like a place with distinctive character?
- 9** Do the buildings and layout make it easy to find your way around?
- 10** Are streets defined by a well-structured building layout?
- 11** Does the building layout take priority over the streets and car parking, so that the highways do not dominate?
- 14** Does the scheme integrate with existing streets, paths and surrounding development?

**Core principles:** integrated, vital, local

## B1.2 The perimeter block

**By default, development should form perimeter blocks by creating connected streets and maintaining well defined frontages.**

*Perimeter blocks offer many advantages, including:*

- *Active frontages*
- *A clear distinction between the public and private realms*
- *Good security by enclosing private space with buildings*
- *Significant contribution to townscape, legibility and spatial enclosure*
- *A robust form that allows for adaptation*

**The design of blocks should not be uniform but should reflect the character of the different surrounding streets that make up the block.**

**Variation in blocks that comes about from the differences between surrounding streets should be used as the basis for introducing variety in building type within a block and street.**

**Special corner buildings or arrangements of plots should be used in corner zones to front both sides of the corner, in particular at the junction of higher order streets and in higher density areas.**

- Blocks should be composed of plot series from each of the surrounding streets so that each side of the block reflects and contributes to the character of the street it fronts.
- Blocks should not be uniform around all sides.

*Variation in the sides of blocks reflecting different orders of surrounding streets presents an opportunity to exploit the different positions within the block.*

- Depending on the location of the block within the route structure, the different zones within a block are likely to include:
  - Main frontage
  - Corners
  - Lower order frontages
  - Interior

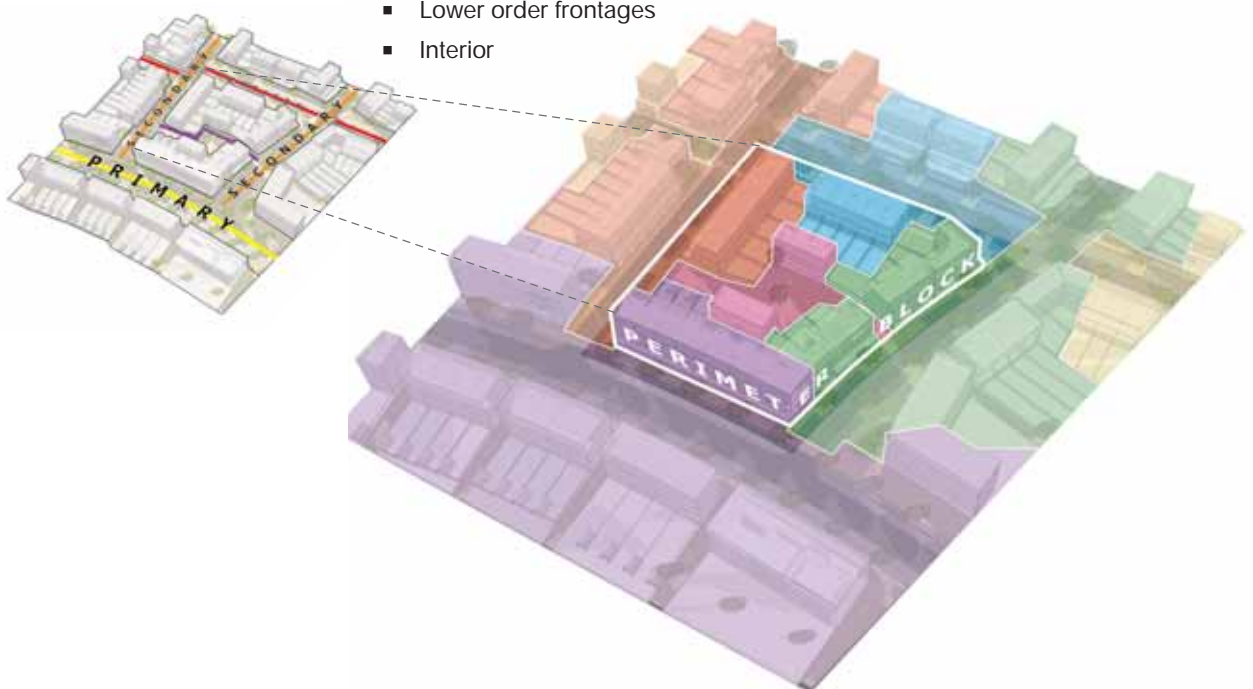

*The perimeter block is the result of creating connected streets. It is made up of plots from each of the surrounding streets*

- The choice of building type within a block should suit the characteristics and constraints of the different zones, corresponding to the character of the surrounding streets.

### Main frontages

- The main frontage onto the highest order street should be the dominant side of the block in terms of relative building size and visual prominence and should have an active frontage along its full length.

### Corners

- Both sides of a corner should include windows and/or entrances for reasons of both security and visual character. The minor side elevation should be properly composed and coordinated with the shape of the elevation and internal spaces.
- Entirely blind gable ends at corners should be avoided, particularly when their orientation makes them more visible from the street.
- Smaller plots and building types can be used in corner locations to make best use of frontage and provide a wider range of building types within the area while still maintaining a strong and coherent character.
- In lower density areas the lower order side of the corner zone can be less active to help mark the change from higher to lower order street.

### Lower order frontages

- Frontages onto the lower order streets should be less prominent and present the less active side on a corner, as determined by the character of the streets.

### General

- Boundary walls for back garden spaces along a street must be of high quality materials, usually brick or masonry and at least 1.8 metres in height to retain privacy. Walls that are too long and/or too high should be avoided (see S1.8).



*The main frontage should have an active front along its whole length and emphasise the status of the street*



*Different building types can be combined on corners to keep both fronts active*



*Lower order frontages provide an opportunity to create a quieter, more intimate environment*

**Building for Life criteria**

- 9** Do the buildings and layout make it easy to find your way around?
- 10** Are streets defined by a well-structured building layout?
- 11** Does the building layout take priority over the streets and car parking, so that the highways do not dominate?
- 12** Is the car parking well integrated and situated so it supports the street scene?

**Core principles:** vital, local, efficient

## B1.3 Using the interior of blocks

The space within a perimeter block serves a number of different purposes and the distance between buildings therefore needs to take into account a number of different considerations.

- Privacy
- Visual mass of buildings
- Amenity space
- Daylighting
- Natural ventilation

In general, if the fronts of buildings face outwards toward the street, the dimensions within a block are the distances from back to back or back to side. The following methods are a few in a range for establishing acceptable dimensions. Alternative methods may be used but must be supported by evidence. Other methods include those in the Code for Sustainable Homes and *Site layout planning for daylight and sunlight: a guide to good practice*, published by the BRE. Exceptions to the following rules may be made for creative solutions that meet other guidelines and seek to solve significant design issues related to the specific circumstances of the site.

### Back-to-back

- For the purposes of privacy and avoiding an ‘overbearing’ relationship between buildings, the minimum back-to-back dimension (between facing habitable rooms) should be 21 metres. This also corresponds to a common minimum rear garden or amenity space of about 10 metres in depth (see 4A.1).
- For the purposes of daylighting, back-to-back distances should, as appropriate to specific circumstances, be limited by the 25 degree rule.

### 25 degree rule

- Taking a horizontal line extending back from the centre point of the lowest window, draw a line upwards at 25 degrees. All built development facing a back window should be below the 25 degree line.
- In exceptional situations such as corner zones and areas with taller buildings, a smaller distance may be acceptable subject to other aspects achieving acceptable standards.

### Back-to-side

- For the purposes of daylighting and avoiding an overbearing relationship, back to side distances and the extent of rear extensions should be limited by the 45 degree rule.

### 45 degree rule

- Taking a horizontal line parallel to the back face of the building at the centre point of the lowest window closest to the side boundary, draw a line 45 degrees upwards and another 45 degrees outwards toward the side boundary. All built development to the side of a back window should be below and behind these lines.
- The above rules also apply to the front or main windows of single aspect dwellings.
- Larger blocks can be subdivided by a mews or mews court, which is essentially a street within the interior of a block.
- In many circumstances the interior of blocks will be used for individual gardens.

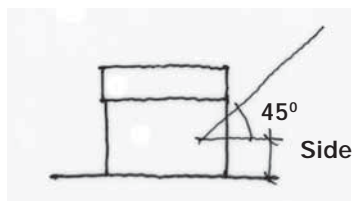
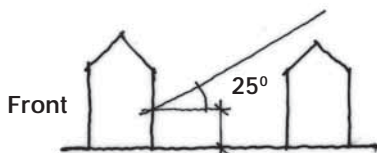

Back elevation

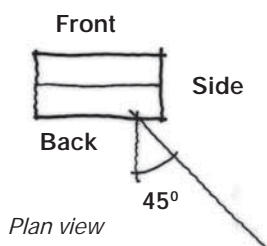

Plan view



*Standard, small terraced house types do not perform well in meeting Code for Sustainable Homes standards, in particular for storage of waste and recycling and access to rear gardens*

In the appropriate locations this space may be designed for shared private use, including a shared garden, courtyard, play space and servicing. See also Section B1.6 on off-street parking.

- Ensure access to the shared private space within a block is controlled and not freely open to the public highway. The perimeter should form a secure boundary to the private space.
- Private space within the block should be buffered from shared private space by a boundary or transition space to avoid conflicts between common and private uses.

*One of the principal benefits of the perimeter block is the clear definition of public and private realms, and the formation of a distinct area within the bounds of the private realm. Particularly with higher density development, the interior of the block provides a potential shared resource for the residents of the block.*

- Access to amenity space or gardens to the rear of properties should be as direct as possible from the street.
- For detached and semi-detached types, access should be direct from the street by a gate.
- Rear access for multi-occupancy buildings may be through a common entrance lobby.
- For terraced types, access to rear gardens should be through a gated access path from either the front street or an occupied mews. The entrance may be to the side or through a ginnel. Access paths should be as short and direct as possible and any single path should not serve more than three or four dwellings.

*See also Secured by Design New Homes for further detail.*

*Access to the interior of the block for terraced types is important for achieving other criteria and guidelines relating to waste and cycle storage, security and safety. It is essential to provide a secure access to the rear of the property without going through the house but still through the main front of the terrace or an occupied street space.*

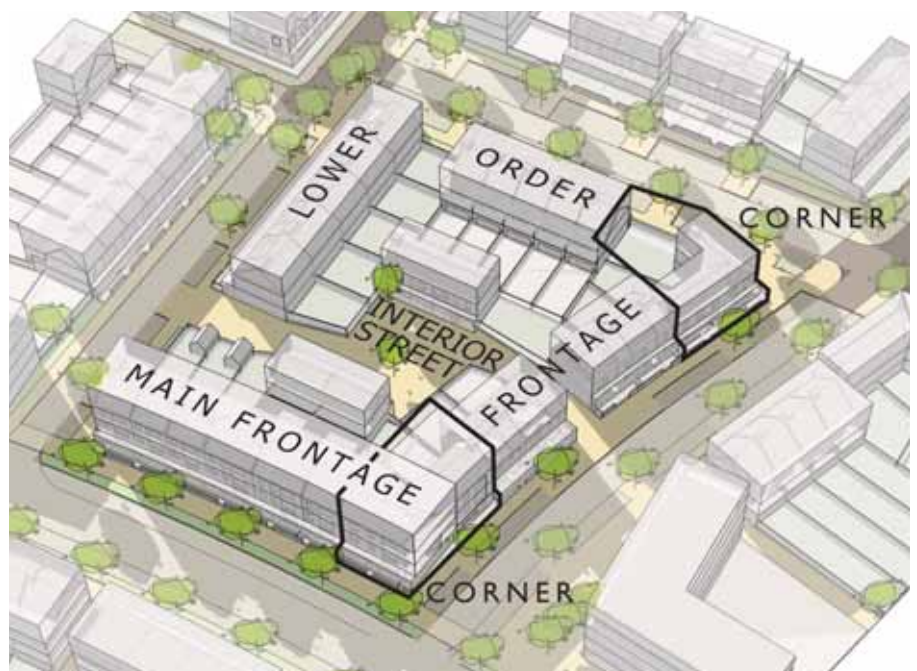

*A wide range of house types, densities and environments can be created within a small area by using the different parts of the perimeter block and surrounding streets*

**Building for Life criteria**

- 9** Do the buildings and layout make it easy to find your way around?
- 10** Are streets defined by a well-structured building layout?
- 11** Does the building layout take priority over the streets and car parking, so that the highways do not dominate?

**Core principles:** vital, local, efficient

## B1.4 Block size and shape

The shape and size of blocks should balance the aims of maintaining the character of the area, creating a walkable street pattern with distinct, connected streets, efficient use of land and good use of the interior of the block.

**In order to avoid a fragmented street pattern and inefficient use of land, blocks should not be too small.**

- Blocks that are more rectangular than square are the most efficient and flexible in adapting to topography, solar and wind orientation.
- Rule-of-thumb dimensions for blocks are 60-90 metres by 90-120 metres, measured from centre line to centre line of the street. Blocks up to 180 metres remain comfortable and accessible. These dimensions are the consequence of putting together typical street, plot and garden sizes and requirements for parking as well as taking into account permeability (supported by the Urban Design Compendium, 3.7.2 on Block Size). Predominant dimensions in an area should be used as a further reference guide.
- Sizes on the larger end of the scale should be used to allow for more on-street parking.
- Larger blocks can be subdivided by mews to help accommodate more parking and increase permeability.
- Considerations for assessing shape and dimensions include:
  - Parking strategy
  - Density
  - Back-to-back dimensions between buildings for privacy and amenity
  - Back-to-back dimensions between buildings for access to daylight
  - Back-to-back dimensions between buildings for natural ventilation
  - Use of the interior of the block for other purposes
  - Topography.

See Section B3.1 for more specific guidance on dimensions.

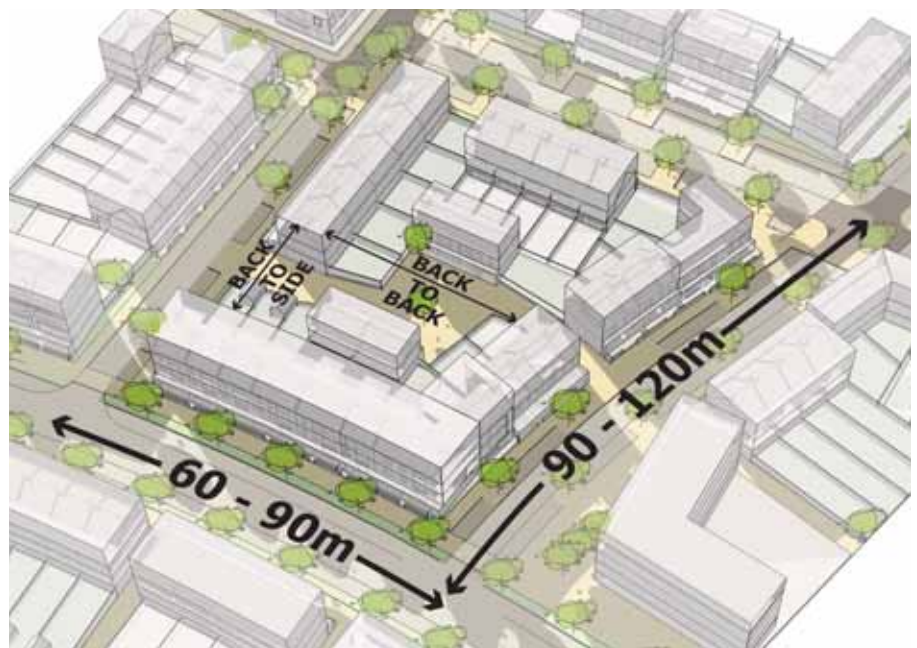

*A key to making best use of the perimeter block and maintaining space standards is to ensure the block is not too small*

**Building for Life criteria**

- 2** Is there an accommodation mix that reflects the needs and aspirations of the local community?
- 6** Is the design specific to the scheme?
- 8** Does the scheme feel like a place with distinctive character?

**Core principles:** vital, equitable, local, efficient

## B1.5 Density

Within the range set by policy, the density of proposed development should be an appropriate response to the character of the area, the location of the site within the settlement, the proximity and accessibility of facilities and services, acceptable levels of parking.

Applicants must demonstrate that all these factors have been taken into account to justify the proposed density.

Density as expressed in the application material must be stated in dwellings per hectare (net dwelling density as defined in PPS3) and, for full and reserved matters applications, in floor area (square metres) per hectare.

- The higher end of the range of densities set by policy is more likely to be acceptable if the following criteria are met:
  - Neighbourhood or district centre within walking distance
  - Employment within walking or cycling distance
  - Public transport within walking distance
  - Adequate public open space within walking distance
  - The form of development maintains or suits the character of the area
  - Provision of an appropriate range of housing type, size and tenure
  - Provision of adequate or more than adequate internal and external space standards.
- As far as possible a range of different dwelling types and sizes should be used to achieve higher densities. Different local densities should be used to achieve a given density over a wider area. Large schemes of a limited type and size will not be acceptable.
- The acceptability of particular densities will be dependent on specific local policies and the character of the immediate area.



*The average density of a development should not necessarily be uniform across the scheme. Variation in building type within the scheme should give different local densities*

**Building for Life criteria**

- 10** Are streets defined by a well-structured building layout?
- 11** Does the building layout take priority over the streets and car parking, so that the highways do not dominate?
- 12** Is the car parking well integrated and situated so it supports the street scene?

**Core principles:** vital, local, efficient



*Front off-street parking is convenient but can dominate a street if not broken up*



*Mews should be well contained and create a distinct and well over-looked space*



*A poor example of front integral garages dominating a street frontage*

## B1.6 Off-street parking

The amount and type of off-street parking should be part of an overall parking strategy (see N5.5 and S2.5).

Off-street parking must be integrated within the overall scheme so that it does not visually dominate the street or shared private areas.

Communal parking for multi-occupancy buildings should be located so that the accessible spaces can be positioned as close as possible to the communal entrance or lift core(s).

Mews and mews courts combine on-street and off-street parking and are deliberately intended to accommodate a relatively high proportion of parking.

All off-street parking spaces, including garages, must be fit for purpose to count as a parking space. Dimensions of garages considered to be fit for purpose are indicated in 4B.1.1.22-26.

Where smaller garages are used, additional on-plot or on-street parking may be required to compensate for garages not being used for their intended purpose. Undercroft parking and car ports will be counted provided they have no other use.

Where a parking space is serving a dwelling that is to meet Lifetime Homes standards, minimum sizes are required.

- There are four general locations for off-street parking relative to the building and street:
  - Front (between the street and building)
  - Integral / undercroft (parking at ground floor below upper storey accommodation)
  - Side (alongside the building)
  - Rear (behind the line of the building away from the street).
- Mews and mews courts are a special case.
- As far as possible allocated spaces should be visible from the property.

### Front

- Front parking, either individual or shared, must allow sufficient space for inclusive access to the building with a dedicated footway between parked cars.
- Front car parking within the curtilage of a dwelling should be set back to maintain clear footways and discourage inappropriate kerb parking.
- The visual impact of front parking, either individual or shared, should be reduced by providing front boundary screening such as low walls/railings, hedges and trees.

### Integral

- On-plot integral garages, underdeck and undercroft parking integral garages should be in line with or behind the main front face of the building.
- To ensure active frontage at ground floor, buildings with integral garages, particularly narrow-fronted and flat over garage types, must not be the only types within a plot series or street.
- Outside of mews and mews courts, plot series of more than three narrow fronted integral garage types, or one flat over garage / undercroft type are not acceptable. Where these types are used plots across the street should generally be non-integral types.

- Consideration needs to be given to the potential impact of integral garages on achieving Lifetime Homes and Wheelchair housing standards.
- Freestanding garages in a front location are generally not acceptable and should not be located where they terminate views down a street.

### Side

- Parking to the side of the building, either open or in a free standing garage/car port, must be set behind the main front face of the building by at least 500mm and should allow for access to the rear of the property.
- In conventional streets, the distance between the front of a garage or car port and the back of pavement should be 6 metres to allow a parking space in front of the garage or, in narrower shared space streets, less than 2 metres, to discourage the obstruction of defined pedestrian zones by parked cars.

### Rear

- Space for parking to the rear of buildings must be in addition to any required garden or amenity space.
- Shared parking to the rear of buildings should be limited to groups of around eight spaces, must be easily overlooked by at least two dwellings and have limited, well overlooked access points.
- Parking to the rear of a corner plot with access from the side street should be limited to three parallel spaces and in all cases must be set back the full 6 metres. The side boundary feature should be a minimum of 1.8 metres and fully enclose the space (if there is no garage) and connect to the house.

### Mews and mews courts

- A mews is a street that runs through and sub-divides a larger block. A mews court is essentially the same but has only one access. A mews or mews court must have at least two dwellings fronting onto the space with ground floor living space. Parking within the street space is dealt with in Section S2.5.
- Off-street parking within a mews or mews court may take a number of forms:
  - Integral (mews buildings or flats over garages)
  - Rear undercroft
  - Car ports.
- There should be no more than six spaces of the same type in a row.

**Building for Life criteria**

- 2** Is there an accommodation mix that reflects the needs and aspirations of the local community?
- 6** Is the design specific to the scheme?
- 8** Does the scheme feel like a place with distinctive character?
- 17** Do the buildings exhibit architectural quality?
- 18** Do internal spaces and layout allow for adaptation, conversion or extension?

**Core principles:** vital, equitable, local, efficient

## B2 Buildings in their plots

### B2.1 Choose the right building types: variety and variation

The choice of plot and building type (size and tenure) must be a suitable response to the character of the area and the site as well as to housing demand and need.

The design of buildings must be 'tenure blind'.

*The design of residential areas should strike a balance between unity and variety. Designs that are too uniform or too mixed should be avoided. Variations should be included within a well ordered whole to deliberately add interest and avoid monotony. Variation should also help contribute to increasing the range of housing size, type and tenure.*

- In order to achieve high quality development at the level of the neighbourhood and development as a whole, it is essential that there is logic to the variation rather than a random sprinkling of different types and sizes.
- Choose the plot and building type to create well defined and coherent streets and neighbourhoods.
- The specific type chosen must suit and/or complement the situation in terms of the following factors:
  - Character of the locality as determined through the appraisal
  - Location relative to a centre
  - The position of the street in the hierarchy
  - The position of the plot within the block and plot series.
- Where there are policies supporting inclusion of Lifetime Homes and/or wheelchair accessible homes, designs for these houses should be a suitable response to the character area and location within the site and layout.

*As set out in Section B1.3, it is possible to fit a wide range of different building types within a block by exploiting the different positions within the block.*



*The character of the area in terms of streets, plots and buildings must be a principal consideration in selecting building types*

**Building for Life criteria**

- 2** Is there an accommodation mix that reflects the needs and aspirations of the local community?
- 6** Is the design specific to the scheme?
- 8** Does the scheme feel like a place with distinctive character?
- 17** Do the buildings exhibit architectural quality?
- 18** Do internal spaces and layout allow for adaptation, conversion or extension?

**Core principles:** vital, equitable, local, efficient

## B2.2 Variants and special types

Different building types should be used to respond to and exploit different positions within the street hierarchy, an individual street, block and plot series.

- The range of different types needed to fully exploit different situations should include the following:
  - Corner types that have active fronts on two adjacent sides
  - Small attached types with a small garden or courtyard, possibly single aspect to make the most of corner zones
  - Wide frontage, shallow depth types for corners and smaller blocks
  - Mews types and/or flat over garage with integral garage(s), possibly single aspect (only to be used within a mews)
  - Rear undercroft types to back onto mews
  - Single aspect types (limited in numbers) for awkward shaped and small blocks.

*Examples of many of these types can be found within existing built up areas, in particular older settlements and centres. Adaptation and reinterpretation of local varieties of special types such as corner types is encouraged.*

- Over-repetitive use of a single 'standard special' type such as a corner type will not be acceptable.
- 'Detached terraced' types, which are standard terraced types, with two blind gable ends, set singly in a plot will not be acceptable.



*Different building types in Wentworth are used to respond to the different parts of the site to create a design that fits the location*



*A distinctive form is used to turn the corner at Heeley, Sheffield*



*A special corner type in Dodworth, Barnsley, specifically designed to occupy a corner site*



*A new corner type that fails to make the most of the corner, leaving the main face of the corner too low, blank and inactive*

**Building for Life criteria**

- 5** Does the development have any features that reduce its environmental impact?
- 19** Has the scheme made use of advances in construction or technology that enhance its performance, quality and attractiveness?
- 20** Do buildings or spaces outperform statutory minima, such as building regulations?

**Code for Sustainable Homes criteria**

Ene 1, Dwelling emission rate, Ene 7, Low and zero carbon technologies

**Core principles:** equitable, efficient

## B2.3 Choice of type and energy use

Use the form of the building as a whole to achieve better energy performance and daylighting. The choice of building type should strike a balance between meeting urban design criteria and reducing energy use and carbon emissions.

*Particularly in the light of Code for Sustainable Homes and Lifetime Homes criteria, it is more important than ever to understand the performance characteristics and capacities of building types in their plot. Some standard types make it difficult to achieve Building for Life, Lifetime Homes and Code for Sustainable Homes criteria.*

- Use of the PassivHaus standard as promoted by BRE is strongly encouraged as a means of meeting Code for Sustainable Homes criteria.

*As noted in the PassivHaus Primer, 'a new-build PassivHaus can typically be expected to achieve the energy requirements of Code level 4 without renewable technologies being specified.'*

- Other means of reducing energy use and carbon emissions include:
  - Higher densities to make district heating more viable
  - Higher proportions of attached, terraced and flatted types to improve the thermal performance of individual dwellings.
  - Higher, isolated buildings to take advantage of small scale wind turbines.



*Taking full advantage of passive solar energy is a strong rationale for new types (stair is secondary)*



*Terraced types have good thermal performance and are well suited to district heating*

**Building for Life criteria**

- 9** Do the buildings and layout make it easy to find your way around?
- 10** Are streets defined by a well-structured building layout?
- 11** Does the building layout take priority over the streets and car parking, so that the highways do not dominate?
- 17** Do the buildings exhibit architectural quality?

**Core principles:** vital, local

## B2.4 Relationship of the building to the public realm

**The frontage of buildings in all new development must fulfil its role as the public front, appropriate to its location within the neighbourhood, street hierarchy and individual street.**

*Particularly within the residential context, the frontage is one of the most important elements of the building in its plot. The frontage, which includes the front façade and front garden, has a significant social role as well as important function in terms of design and character. It is the public face of the building.*

- As appropriate to the character of the area and location in the street hierarchy, a transition or buffer zone of at least 1 metre should be provided between the fronts of dwellings and the public highway and/or communal open space to avoid an abrupt shift from exterior to interior (public to private), to provide opportunities for social interaction and better integrate the components of the street.
- Locations where a 'back of pavement' position may be appropriate include centres and higher density areas, streets lower in the hierarchy with low levels of vehicle movement and mews or mews courts.
- The difference between public, private and shared-private spaces should be clearly identifiable without the use of signage.
- The front space, including the boundary treatment, should be a key feature in maintaining local distinctiveness.



*The combination of active openings and more elaborate detail in Old Town, Barnsley, create a strong public front to the building*



*This street in Doncaster is made a welcoming place by the concentration of windows and well kept front gardens*



*The transition space at the entrance gives a balance between privacy and an active frontage (the stair is a secondary entrance)*

## B2.5 Private and shared private outdoor space

Private and shared private outdoor amenity space for active use must be secure and endeavour to have sufficient sunlight.

Shared private space should be located where it is well overlooked both by people moving through or past the space and from windows.

Undefined or unenclosed space around the outside of multiple occupancy buildings is not acceptable as shared outdoor space for active use.

Consider inclusion of space for the cultivation of vegetables and fruit.

All buildings should include level thresholds to gardens that can be used by all.

All shared amenity and play space must have an identified body to manage and maintain the space in accordance with an agreed management plan.



*This shared play space is well overlooked but is also large enough to ensure it does not have a negative impact on the dwellings*

**Building for Life criteria**

- 5** Does the development have any features that reduce its environmental impact?
- 6** Is the design specific to the scheme?
- 8** Does the scheme feel like a place with distinctive character?
- 14** Does the scheme integrate with existing streets, paths and surrounding development?
- 17** Do the buildings exhibit architectural quality?
- 19** Has the scheme made use of advances in construction or technology that enhance its performance, quality and attractiveness?

**Core principles:** vital, equitable, local, efficient



The basic building types in South Yorkshire are relatively simple in form and for that reason are versatile in how they can be adapted to new standards

## B3 Building design

### B3.1 Overall building form

*The overall form of a building has a significant effect on how well it can be integrated into a plot series and street and so the overall character of the area. It also has an impact on the potential for making use of passive solar heating and daylighting and achieving space standards.*

*Choice of overall form must therefore be based on:*

- *Topography*
- *Solar orientation*
- *Location within the plot, series and block*
- *Location within the street and street hierarchy*
- *Location relative to a centre*
- *The predominant forms in the locality.*

**The overall form and detailed design of buildings should be appropriate to their location within their neighbourhood and character area as well as within the street and block or plot series. The design of buildings should enhance the character of the surrounding area.**

- As with the design of the public realm, the overarching principle in the design of buildings should be simplicity. This does not mean 'stripped down', least cost design but well considered, unfussy and uncluttered design.
- By default, use simple forms of a scale similar to buildings in the locality.
- Reinterpret local types to suit today's needs.
- Smaller footprint buildings must be used on steeper slopes so the roofscape follows the slope of the land.
- Larger buildings should be articulated in form to reduce their perceived mass to a scale similar to local forms.

### B3.2 Internal space standards

**All new dwellings should be fit for purpose in terms of internal layout, dimensions and space standards.**

*Choice of overall form must therefore be based on:*

- *Bedrooms*
- *Living rooms*
- *Dining rooms (living room/dining room)*
- *Kitchens (kitchen/dining room)*
- *Open plan combinations*
- *Bathrooms*
- *Storage.*

*Further indications on space standards are included in Section 4A.2.*



*Double pitched roofs with gable ends like this one in Tickhill, Doncaster, are one of the predominant roof forms in South Yorkshire*

### B3.3 Roof form

The roof forms of buildings should be appropriate to their location within their neighbourhood and character area as well as within the street and block or plot series.

- The form of the roof should be simple and express and articulate the form of the building rather than obscure it.
- When using pitched roofs, the ridge should, in general, be roughly parallel to the line of the street (or thereabouts) unless specific circumstances or local positive character indicates otherwise. Narrow frontage, detached buildings with a ridge spanning the narrow axis should only be used in closely spaced groups with a common orientation to give the impression of one longer ridge along the series.
- High pitch angles should not be used over deep spans to avoid over-dominant roof forms.
- The position of downpipes should be integrated with the design of the roof and façade to minimise the visual impact of the pipes.
- Dormers should not be over-dominant and fussy.
- Use combined service cores for gas flues and vent outlets as well as natural ventilation hoods to give vertical articulation to roofs.
- Consider the potential for the use of green roofs.



*New designs can be introduced that still maintain local proportions and character*

### B3.4 Openings and articulation

The façade arrangement, type and proportion of openings of buildings should be appropriate to their location within their neighbourhood and character area as well as within the street and block or plot series.

- The façade should be well considered and coherent as viewed from the street.
- Front doors should be prominent and, in particular, more prominent than garage doors.
- Entrances should address the street and be regularly spaced to achieve active frontage. Designs that have separate entrances for ground and upper floor flats are encouraged.
- By default, windows and doors should be vertically and horizontally aligned. Avoid arrangements that are almost but not quite aligned. Exceptions can be made for strong architectural compositions.
- Particularly when using traditional masonry materials, window and door openings should have a sufficient recess to give visual articulation. Exceptions can be made where a flush detail is part of a deliberate and coherent architectural composition.



*The range of equipment and storage now standard on dwellings must be integrated into the design from the start*

## B3.5 Installations, equipment and storage

**The inclusion of equipment and storage on the public fronts of buildings must not result in visual clutter of the façade or street space.**

- Meter boxes should be located for safe and convenient access but must not have a dominant or detrimental visual impact on the principal façades.
- Where possible, a common satellite dish should be provided for a series or group of dwellings. Position dishes away from principal façades. Install alternative television systems, such as cable, in developments wherever possible.
- Exhaust all possible locations for waste and recycling storage before placing it on the building frontage. If there is no alternative, storage must be integrated into the design of the frontage, visually unobtrusive and secure, to avoid vandalism/arson.
- Waste and recycling storage should be accessible to all home users (including disabled people) and any assisted collection service.
- As far as possible combine storage, services and meter installations in a 'service core' that acts as an architectural and visual component of the design. The location of common waste storage areas needs to take into account maximum 'carrying' distances (refer to individual local authorities for distances).



## B3.6 Materials and colour

*The materials and colour of development, which is to say, its visible surface, provides one of the strongest cues to our perception of local distinctiveness. On their own, colour and materials are not enough to create a sense of commonality with the area but they do make a significant contribution.*

**Materials, details and colour of buildings should be appropriate to their location within their neighbourhood and character area as well as within the street and block or plot series.**

- Colour and materials should be included as key characteristics that new development shares with the locality in seeking to retain local character.
- Use the predominant materials typical of the distinct landscape character areas and settlements.
- As far as possible, use locally sourced materials.



*The traditional local building materials in South Yorkshire such as stone and brick provide a point of reference the colour and texture of new materials*



# 4

## Technical requirements



## 4A Amenity and internal space standards, safety and security

### A.1 Amenity space

#### Back gardens

- A.1.1 Back gardens of houses should be appropriate to the size of the property, its orientation and likely number of inhabitants. Private gardens of two bedroom houses/bungalows should be at least 50 square metres; for three or more bedroom houses/bungalows, 60 square metres. Smaller gardens may be acceptable in corner zones of blocks if privacy and daylighting can be maintained.

#### Shared private space

- A.1.2 Shared private space for flats must be a minimum of 50 square metres plus an additional 10 square metres per unit either as balcony space or added to shared private space.
- A.1.3 Where shared private space cannot be provided balconies must be provided.
- A.1.4 Balconies must be a minimum of 3 square metres and provide usable space clear of door swings to count toward the minimum requirements.
- A.1.5 The amount of shared private space to be provided will also depend on the quality, quantity and accessibility of local public open space.
- A.1.6 External space should be designed as an integral part of the development, with priority given to private rather than communal space.
- A.1.7 Shared private space must be located where it is:
- accessible to disabled people
  - well overlooked and near active lines of movement
  - takes advantage where possible of long distance views and mature planting
  - receives sunshine over at least half the area on 21 March/September.
- A.1.8 Children's play space should be located where it is:
- well overlooked and near active lines of movement
  - receives sunshine over at least half the area on 21 March/September
  - does not conflict with other uses in terms of noise.
- A.1.9 A percentage of the useable area of Home Zones and multi-functional green space may qualify as children's play space subject to discussion with the Local Planning Authority.
- A.1.10 Please refer to the Fields In Trust guidance for further indications on design.
- #### Management
- A.1.11 All shared amenity and play space must have an identified body to manage and maintain the space in accordance with an agreed management plan.

## A.2 Internal space standards

A.2.1 The minimum standards for internal spaces set out in the table 4A.1 below have been derived from a comparative analysis of a range of sources including detailed research and minimum space standards adopted by a number of local authorities. Meeting these space standards, including the minimum room dimensions, will help to achieve Lifetime Homes standards and score points for Adaptability (criterion 18) in the Building for Life assessment.

Double Bedroom	12	12	12	12	12	
Single Bedroom		7	7	7	7	
Living Room (L)	13	13	13	15	15	
Living/ Dining (DL)	16	16	17	18	19	
Dining room (D)						
Kitchen (K)	13	9	11	13	13	
Kitchen/ Dining (KD)	9	13	13	11	12	
Open Plan/ combined (KDL)	24	24	27	30		
Bathroom/ WC combined	3.5	3.5	3.5	3.5	3.5	
Storage	1.5	2.5	3.5	3.75	4.5	5.5
<b>Overall floor area</b>	<b>33</b>	<b>46</b>	<b>47</b>	<b>62</b>	<b>77</b>	<b>93</b>

*K=cooking, D=eating, L=living*

*Table 4A.1 Space Standards*

The space standards are derived from in-depth research carried out for CABE and the Greater London Authority (HATC Ltd and Ipsos-MORI (2009) *Resident satisfaction with space in the home* CABE, London; HATC Limited (2006) *Housing Space Standards*, Greater London Authority, London) and a comparative assessment of space standards as adopted by a range of local authorities including Basingstoke, Croydon, Haringey, Lambeth, Mid-Sussex, Richmond, Southwark and Watford.

**Minimum room dimensions**

- A.2.2 Living rooms and bedrooms should not exceed a width to length ratio of 2:1 (i.e. must not be too long and thin).
- A.2.3 Double bedrooms should be a minimum of 3 metres in length and 2.6 metres in width and for a single bedroom, 2 metres in width.
- A.2.4 Living rooms should have a width or length of at least 3.2 metres.
- A.2.5 In Lifetime Homes and wheelchair housing, rooms must also be large enough to accommodate the manoeuvring and access requirements for wheelchair users. They must also accommodate accessibility features such as entrance level bedspaces and through-floor lifts while remaining usable rooms.
- A.2.6 The minimum ceiling height should be 2.3 metres.
- A.2.7 All plans of buildings submitted for planning permission must show furniture in all the rooms.

**Storage and utility space**

- A.2.8 The minimum standards for storage space per dwelling are set out in table 4A.1.
- A.2.9 Points for the following criteria from the Code for Sustainable Homes relating to storage and utility space are also desirable to attain:
- Daylighting
  - Storage of waste
  - Drying space
  - Cycle storage
  - External water use.
- A.2.10 Solutions need to ensure there is access to the storage from the street without having a detrimental impact on the fronts as active frontage or in terms of aesthetic quality.
- A.2.11 External communal storage facilities, in particular for waste and recycling, must be well located in terms of convenience of access as well as aesthetic impact on the scheme. Facilities must be visible and secure but must not be visually prominent.
- A.2.12 Any common cycle parking must be secure, well lit, well overlooked and easy to get to. The preference should be for common cycle parking within the shell of a multi-occupancy building.

**A.3 Lifetime Homes**

- A.3.1 Where the local planning authority has the appropriate adopted policies in place, new development will need to meet Lifetime Homes standards. Where this is not the case, the standards should be achieved wherever feasible. Notwithstanding policy requirements, these standards will be used to inform Building for Life assessments.
- A.3.2 Consultation with disabled people has highlighted the importance of the following features:
- The importance of lift access to flats above and below entrance level to blocks
  - The difficulties created by integral garages and the importance of living accommodation being provided on the same level as the main entrance

- The importance of keeping the use of a bedroom when a through floor lift is installed
- The importance of washbasins being usable from toilets
- The value of adopting the additional good practice recommendations set out in the guidance.

A.3.3 Refer to the Lifetime Homes website for further details of the most current provisions required to meet these standards: [www.lifetimehomes.org.uk](http://www.lifetimehomes.org.uk).

#### **A.4 Wheelchair housing**

A.4.1 Where the local planning authority has the appropriate adopted policies in place, a percentage of dwellings in all new development must be provided as wheelchair housing as identified in Lifetime Homes, Lifetime Neighbourhoods and BS 7000-6, *Managing inclusive design*. Where there is no supporting policy, the standards should be achieved wherever feasible. Notwithstanding policy requirements, these standards will be used to inform Building for Life assessments. The specific percentage is to be agreed with housing and accessibility officers.

A.4.2 Housing designated as homes for disabled or older people must be fully accessible to wheelchair users in accordance with the requirements and recommendations of the 'Wheelchair housing design guide' by Stephen Thorpe and Habinteg Housing Association. Housing which is readily adaptable for residents who are wheelchair users must meet basic standards of wheelchair accessibility based on the 'Wheelchair housing design guide'.

A.4.3 Provision of designated homes and the specific percentage of readily adaptable housing is to be agreed with housing and access officers.

#### **A.5 Safety and security**

A.5.1 In addition to measures that can be achieved in the layout of streets and plots to create a safe and secure environment, there is a range of measures that can be taken at the level of the individual dwelling. For detailed advice on safety and security measures in the design of buildings, contact the local Crime Prevention Design Officer from South Yorkshire Police. As a starting point, the following specifications are recommended.

- Doors: Publicly Available Specification PAS024 (to become BS 6375) – the Secured By Design standard for front, side and rear doors
- Window frames: BS 7950 – the Secured By Design standard for ground floors, basement and easily accessible windows
- Glazing: Laminated glass 6.4 mm on all ground floors, basement and easily accessible windows
- Communal entry doors: no more than 10 apartments per door
- Window frames: BS 7950 – the Secured By Design standard for ground floors, basement and easily accessible windows
- Glazing: Laminated glass 6.4 mm on all ground floors, basement and easily accessible windows

## 4B Street and parking geometry

Note: This section provides geometric parameters for the design of new streets which designers will normally be expected to comply with. However, innovation is welcomed, and designers are welcome to put forward alternative design approaches, which will be considered by the local highway authorities on their merits.

### B.1 LINKS: GENERAL PARAMETERS

#### B.1.1 Street Types

##### Conventional Streets

B.1.1.1 Conventional streets have a carriageway and footway, generally separated by a kerb of 100mm height and distinguishable by colour contrast. There is no upper traffic flow limit for conventional streets.

##### Shared Space Streets

B.1.1.2 Shared Space Streets have reduced differentiation between vehicle and pedestrian areas. Shared Space Streets will be limited to more lightly-trafficked routes within predominantly residential areas.

Two types of Shared Space Street are identified, depending on traffic flow volumes and hence the need to provide an area exclusively for pedestrians, and to meet the particular needs of blind, partially sighted and other disabled people:

- Shared Space Streets with physically demarcated protected zones for pedestrians
- Shared Space Streets with a level surface, only where vehicle flows are very low.

##### Shared Space Streets with Protected Zone

B.1.1.3 In these streets it will be necessary for part of the street to be kept free of traffic and hence for the sole use of pedestrians. This protected zone can be defined by a range of measures subject to agreement with highway and access officers. Typical measures include kerbs, textured surface and colour contrast providing a continuous demarcation between the vehicle zone and the protected zone, aiding navigation for people with a visual impairment, and helping to control vehicle movements. A range of other features can be used to supplement and support the function of the protected space such as trees, verges or street furniture.

B.1.1.4 Design parameters for Shared Space Streets with Protected Zone:

- Gateway or entry treatment
- Target design speed of 10mph
- Low vehicle flows (average two-way peak hour traffic < 100 vph)
- Largest regular vehicles – refuse truck
- Protected Zone:
  - Recommended minimum width 1.5m
  - Absolute minimum width 1.2m where pedestrians can step out of the zone to pass each other, 1.5m elsewhere
- Protected Zones, preferably on both sides of street, but may be limited to one side where the needs of disabled people can be safely and conveniently met by using only one route and enabling effective wayfinding and street-crossing to all dwellings or community facilities
- Street parking to be limited to defined spaces outside of the protected zone but with access directly to them

- Crossing points on desire lines to be provided with flush or drop kerbs and blister tactile paving behind the protection line
- Street lighting options:
  - Column at rear of protected zone
  - Column protected locally (e.g. by wall, bollards)
  - Wall-mounted lighting.

#### Shared Space Streets with Level Surface

B.1.1.5 Where traffic flows are extremely light it will be acceptable for an undifferentiated level surface to be designed which is used by motor vehicles and all pedestrians. This is to be agreed with highway and access officers. Although no protected zones will be provided, it will still be necessary for visually-impaired people to be able to find their way along the street to and from their destination using a continuous feature such as a consistent building line, another tapping feature such as a berm and plasmobility kerb, or tactile guidance paving. A tactile warning should be provided to safeguard visually impaired people from walking out into the main carriageway.

B.1.1.6 Design parameters for Shared Space Streets with level surface:

- 'Gateway' or entry treatment incorporating a tactile warning for visually impaired pedestrians leaving the street
- Entrance to the street(s) may be via footway crossing depending on vehicle flows
- Extremely low vehicle flows (a reference guide is an average two-way peak hour traffic of <40 vph but individual cases must be agreed with officers)
- Largest regular vehicles – refuse truck
- Design speed 10mph
- Street parking to be limited to defined spaces away from pedestrian desire lines
- Street lighting options:
  - Column behind plasmobility kerb in berm
  - Column protected locally (e.g. by wall, bollards)
  - Wall-mounted lighting
- Where conventional drainage systems are in use a berm and plasmobility kerb are preferred along at least one side of the street to allow for gully placement.

#### Home Zones

B.1.1.7 Home Zones are streets that are designed to be used by the community for a range of activities, as well as places for vehicles. Both types of Shared Space Street can also be designated as Home Zones, but this will also require:

- The provision of features to encourage the community to actively use the street, such as seating and informal play sculptures
- Home Zone signage at the entrance to the street(s)
- Designation under the Transport Act (2000).

Further guidance on the design of Home Zones is given in the Sheffield Home Zone Guidelines (2008) and the IHIE *Home Zone Design Guidelines* (2002); and on the designation process in DfT Circular 02/2006, *The Quiet Lanes And Home Zones (England) Regulations 2006*.

#### Private Drives

B.1.1.8 Note – dimensional guidance contained in this section also applies to accesses to shared parking facilities – see [B.1.1.19](#).

B.1.1.9 Shared Private Drives are unadopted and may give access up to a maximum of 5 dwellings. This limit relates to the notional capacity of a private service connection, which would not need to be laid in an adopted highway.

B.1.1.10 However, in view of the on-going maintenance liabilities for householders, developers are encouraged to minimise the use of private drives for communal use and seek to extend adoptable areas wherever practicable. Where used they must be surfaced with a bound graded material.

B.1.1.11 Dimensions:

- Maximum length 20 metres without a turning facility suitable for a fire appliance
- Minimum carriageway width of 3.1 metres
- Widening may be needed at the entrance to the private drive to allow two cars to pass, depending on the nature of the street from which access is taken. This widening will need to be between 4.5 metres and 4.8 metres for a minimum length of 10 metres
- Passing places of minimum width 4.5 metres and minimum length 6 metres may be required depending on the length of the private drive, at the discretion of the Highway Authority.

B.1.1.12 Means of wayfinding for blind and partially sighted people, and a tactile warning for those leaving the drive where necessary, should be provided.

B.1.1.13 Permeable or porous surface materials and, where possible, soakaways should be considered for private drives to reduce runoff.

#### **Off-street parking**

B.1.1.14 On-street parking is dealt with in Section S2.5 and 4B.2.1.18-27. The following provides guidance for off-street parking.

#### **General**

B.1.1.15 Cycle and motor cycle parking as well as car parking must be considered from the outset as part of a comprehensive strategy. Weather protection should be provided wherever possible.

B.1.1.16 Allocated spaces are solely for the use of occupiers and their visitors. At least one allocated space per unit is required for wheelchair accessible housing and recommended for Lifetime Homes and housing which is readily adaptable for residents who are wheelchair users. Unallocated spaces are provided for general use and can be provided in bays on and off the carriageway. Where allocated spaces are not provided for Lifetime Homes, at least one space within each parking bay/location/lift core location and/or 10% of the overall number of spaces should meet the required standard. Additional accessible spaces should be provided where allocated spaces are not provided for housing which is readily adaptable for residents who are wheelchair users.

B.1.1.17 Access to shared private off-street parking (private drives or driveways) is normally unadopted. In view of the on-going maintenance liabilities for householders, however, developers are encouraged to minimise the use of private drives for communal use and seek to extend adoptable areas wherever practicable.

B.1.1.18 Provision of an off-street or allocated parking space that is easily adaptable for wheelchair users is strongly recommended for each Lifetime Home or wheelchair housing.

#### **Access dimensions**

B.1.1.19 Access (driveways) to individual parking should be no less than 3.3 metres in width to allow for a pathway to the house. If the access does not have to provide a pathway to the house a 2.75 metres width is acceptable but parking spaces must be capable of being widened to 3.3 metres in accordance with Lifetime Homes criterion. For wheelchair housing, the drive width must be 3.6 metres.

B.1.1.20 Accesses to shared parking areas should have the following dimensions:

- Maximum length 20 metres without a turning facility suitable for a fire appliance
- Minimum carriageway width of 3.1 metres
- Widening may be needed at the entrance to the private access to allow two cars to pass, depending on the nature of the street from which access is taken. This widening will need to be between 4.5 metres and 4.8 metres for a minimum length of 10 metres
- Passing places of minimum width 4.5 metres and minimum length 6 metres may be required depending on the length of the private access, at the discretion of the Highway Authority.

B.1.1.21 Reference should be made to Section [4B 1.1.8-13](#) for further guidance on the design of shared private accesses.

#### Space dimensions

B.1.1.22 Standard parking spaces must be 5 metres by 2.5 metres. Spaces required to meet Lifetime Homes standards should preferably be 3.3 metres wide, and should always be capable of enlargement to attain 3.3 metres width. Spaces required to meet wheelchair housing standards must be covered and at least 6 by 3.6 metres. The parking for communal areas should normally be at 90 degrees. Designated accessible parking spaces in accordance with BS 8300 are preferred for Lifetime Homes, wheelchair housing and disabled visitors. The aisle width should be 6.0 metres, which may be reduced by widening the bays, as set out in Section [4B.2.1.18-27](#).

B.1.1.23 Best practice suggests the internal floor area for car spaces (garages or car ports) should be 3 x 6.5 metres, 4.2 metres wide with an automatic door for wheelchair housing and 3.6 metres wide to count as a Lifetime Homes standard parking space. Spaces might be larger to accommodate larger vehicles (4x4s), cycles and general storage. Spaces that are smaller than the minimum may be included but will not be counted as a parking space.

B.1.1.24 The forecourt depth is 6.0m for garages and 5.5 metres for garages with a roller shutter door. Additional length for turning of 1 to 3 metres may be required depending on the specific circumstances.

B.1.1.25 Bays in front of a garage (tandem space) should be a minimum of 6.0 metres.

B.1.1.26 Vertical clearances to suit the vehicles to be accommodated in the parking area should be:

- |                          |             |
|--------------------------|-------------|
| • Cars (including 4x4s)  | 2.1 metres  |
| • Accessible spaces      | 2.6 metres  |
| • Small service vehicles | 2.5 metres  |
| • Touring caravans       | 2.8 metres  |
| • Motor Caravans         | 3.3 metres. |

#### Other matters

B.1.1.27 On-plot spaces are preferred where practicable for wheelchair housing and to meet Lifetime Homes standards. Where allocated spaces are unavailable within the plot, parking should be provided within 40m of the entrance to the property. The distance should be 20 metres for wheelchair housing and preferably 15 metres to 30 metres for Lifetime Homes spaces. Where communal parking is provided for multi-occupancy buildings, these distances apply to the main communal entrance of the building (or another accessible entrance in general use) or the nearest lift core.

- B.1.1.28 It is preferable to have a level approach. However, where the topography prevents this, a maximum gradient of 1:12 is permissible on an individual slope of less than 5 metres or 1:15 if it is between 5 and 10 metres, and 1:20 where it is more than 10 metres. Paths should be a minimum of 900mm width. Where a ramped approach is provided to a dwelling, the parking space should be located at floor level adjacent to the main entrance. These apply to on-plot spaces not communal spaces.
- B.1.1.29 Any surface water run-off from the plot (curtilage) of private property should not discharge into the highway system of drainage. Separate connections must be made by the developer to the public surface water system.
- B.1.1.30 Permeable or porous surface materials and, where possible, soakaways should be considered for parking areas to reduce runoff.
- B.1.1.31 Visibility splays of 2.0 x 2.0 metres may be required where a private (3.3 metres) drive joins the back of footway in the interests of pedestrian safety. These should be kept clear of obstructions over 900mm in height. Reference should be made to Section 7.8.3 of *Manual for Streets* for guidance on when footway visibility splays may be necessary.
- B.1.1.32 The design of the splay should take into account:
- The frequency of vehicle movements
  - The amount of pedestrian activity
  - The width of the footway
  - The value of a garden boundary to the street design.
- B.1.1.33 Private single and shared driveways should be surfaced with bound materials to prevent any stones, gravel or similar items from being deposited on the adoptable area; where used they must be surfaced with a bound graded material.

## B.1.2 Design Speed

### B.1.2.1 Residential Streets - General

Streets principally serving residential areas are to be designed to achieve traffic speeds of no more than 20mph.

Shared Space Streets, where segregation between motor vehicles and other road users is reduced, should be designed to achieve speeds of around 10mph and always below 15mph. Further advice on the design of shared space streets is given in sub-section 4B.1.1.2-7 above.

#### Principal streets

- B.1.2.2 Higher design speeds, of up to 30mph, may be appropriate in the following circumstances:

- Existing routes within built-up areas
- In larger developments, where the extent of the 20mph streets would otherwise exceed around 1km
- Principal bus routes.

- B.1.2.3 The need for design speeds above 20mph will be determined on a case-by-case basis.
- B.1.2.4 Guidance on the design of speed restraint measures is given in 4B.4, below.

- B.1.2.5 Note: The speed limit in new developments will generally be set at 30mph regardless of the design speed in order to minimise signage clutter, but in some situations it may be appropriate to establish a 20mph speed limit or zone. Further advice on speed limits is given in DfT Circular 01/2006, *Setting Local Speed Limits*.

**B.1.3 Forward Visibility**

**B1.3.1 Carriageways**

Forward visibility along carriageways is measured along the centre of the lane at intervals to create a visibility envelope. Visibility should be measured in both the horizontal and vertical planes.

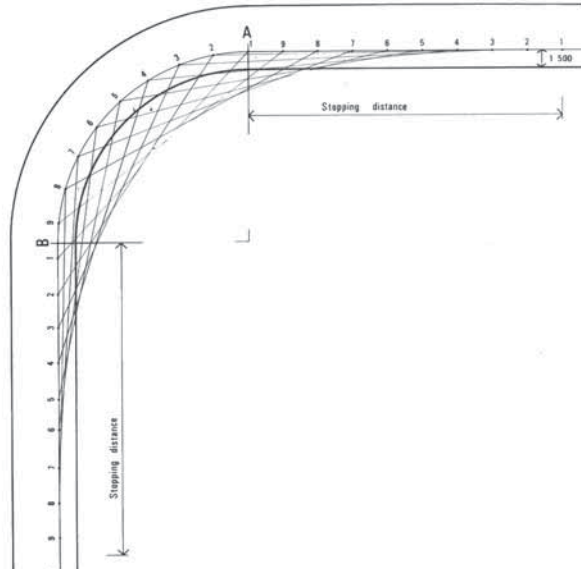

B.1.3.2 To construct a forward visibility curve around a bend:

- a) A line should be drawn, parallel to the inside kerb in the centre of the inside lane (typically 1.5 metres from the kerb) to represent the path of a vehicle.
- b) The required stopping sight distance should be measured back along the curved vehicle track around the curve from the tangent point A.
- c) The stopping sight distance should then be divided into equal increments of approximately 3 metres and the increment points numbered in sequence.
- d) The stopping sight distance should then be repeated around the curve, finishing a full stopping sight distance beyond the tangent point B, and similarly divided into equal numbered increments, starting again with point number 1.
- e) The area to be kept clear of obstruction should then be constructed by joining increments of the same number, 1 to 1, 2 to 2, etc.

B.1.3.3 Visibility is measured between eye heights of 0.9 and 2 metres; and object heights of 0.6m and 2m. Generally the measurement between an eye height of 0.9 metres and an object height of 0.6 metres is critical, at crest curves.

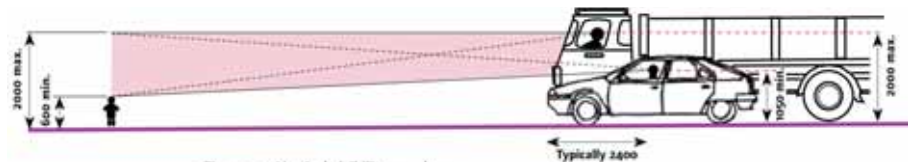

B.1.3.4 Forward visibility shall be provided as follows:

- On streets with a design speed of 20mph and below, forward visibilities below those given in Table 7.1 of *Manual for Streets* will be permissible, since limiting forward visibility assists in reducing traffic speeds, but a minimum forward visibility of 15m shall always apply.

- On higher speed streets, minimum forward visibilities should be derived from Table 7.1 of Manual for Streets, which are reproduced below.

Speed	Kilometres per hour	16	20	24	25	30	32	40	45	48	50	60
	Miles per hour	10	12	15	16	19	20	25	28	30	31	37
SSD adjusted for bonnet length.		11	14	17	18	23	25	33	39	43	45	59

Although these minimum visibilities should be provided, it should be noted that curtailing long views for drivers will help in reducing traffic speeds, as set out in Chapter 7 of *Manual for Streets* and sub-section 4B.4.2.1.

**Off-carriageway cycletracks**

B.1.3.5 See 4B.2.2 for general considerations on cycletracks.

Minimum forward visibility on off-carriageway cycletracks (derived from *Local Transport Note 2/08, Cycle Infrastructure Design*)

- Minimum Stopping Sight Distance:
  - Commuter Route – 25 metres
  - Local Access Route – 15 metres.

**Securing forward visibility splays**

B.1.3.6 Forward visibility will need to be secured either through:

- visibility splays across adopted highway
- sight lines over unadopted land, secured through a covenant.

B.1.3.7 Isolated obstacles such as street trees (providing they have a clear stem of 2 metres), street lighting columns and sign poles will be acceptable within visibility splays.

**B.1.4 Horizontal Alignment**

**Carriageways - Centreline Radius**

B.1.4.1 On 20mph and below streets, no minimum centreline radius will be applied, as changes in direction can act as speed restraint measures.

B.1.4.2 On streets with higher design speeds, a minimum centreline radius of 30 metres will generally apply, although lower radii may be achievable in conjunction with local speed reducing measures – see advice on speed control in sub-section 4B.4.

B.1.4.3 Track testing of curves to determine requirements for widening on bends will be required in accordance with sub-section 4B.2.1.28-32, however.

**Off-Carriageway Cycletracks - radius**

B.1.4.4 Desirable minimum centreline radii:

- Commuter Route – 25 metres
- Local Access Route – 15 metres.

## B.1.5 Vertical Alignment

### Longitudinal Gradients

#### B.1.5.1 Minimum gradient for drainage:

- 0.67% (1 in 150) on carriageways, and footways and cycletracks, although channel summitting will be acceptable in flat terrain.

#### B.1.5.2 Maximum gradients for carriageways and footways:

- Desirable maximum gradient – 5% (1 in 20).

#### B.1.5.3 In steep terrain, carriageway gradients of up to 10% (1 in 10) may be permissible, at the discretion of the highway authority.

#### B.1.5.4 On the minor arm approach to junctions, platforms with a maximum gradient of 5% (1 in 20) (up or down) will be required for a minimum distance back from the give way line of 5 metres, or up to the tangent point of the corner radii if greater.

#### B.1.5.5 Where roads, footpaths and cycleways with a gradient exceeding 8% (1 in 12.5), or where severe bends together with gradients may cause localised problems, grit bins will be required for public use. Such bins should be positioned so as to be clear of the paved area used by vehicles, pedestrians and cyclists.

#### B.1.5.6 Maximum gradients for off-carriageway cycletracks:

- Desirable maximum gradient – 3% (1 in 33)
- Desirable maximum lengths of steeper gradients:
  - 5% (1 in 20) - 100 metres
  - 7% (1 in 14) - 30 metres
- However, where these values cannot be achieved, it is better to have a steep cycletrack than none at all.

### Vertical Curvature - Carriageways

#### B.1.5.7 Carriageway vertical curve lengths are to be calculated using the formula $L=KA$ , where L is the length of curve in metres, A is the algebraic difference in gradients and K is a constant factor. Curves are also subject to a minimum length. Values are as follows:

- 20mph and below streets: Min K = 1.0, Min curve length = 10 metres
- Other streets: Min K = 4, Min length = 25 metres.

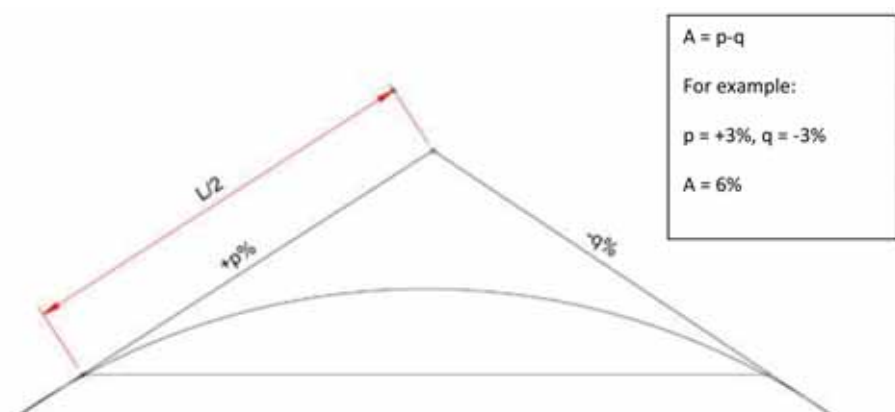

**Headroom**

B.1.5.8 Minimum headroom over adopted highways:

- Carriageways – in accordance with DMRB TD 27/05 – Cross Sections and Headroom. This is generally 5.3 metres for new construction plus any allowance for vertical sag curvature. The minimum headroom for maintained structures is generally 5.03 metres plus sag allowance.
- Cycletracks, Footways and Footpaths – 2.6 metres.

**Crossfall**

B.1.5.9 Carriageway cross-section to be cross-fall or cambered to a gradient of 2% to enable more comfortable pedestrian use, but gradients of up to 2.5% (1 in 40) will be required where necessary to achieve adequate drainage.

Superelevation will not be required on new highways with a design speed of 30mph or less.

**B.1.6 Access****Vehicular Access to Properties**

B.1.6.1 The following restrictions apply to the provision of direct vehicle access to properties. See sub-section 4B.3.2 for criteria on the design of footway crossovers.

B.1.6.2 20mph and below streets:

- No restriction on vehicle access to individual dwellings.

B.1.6.3 Higher design speed streets:

- Direct access is generally permissible for two-way traffic flows up to 500 vehicles per hour
- Direct access may be permissible for two-way traffic flows up to 1,000 vehicles per hour, but turning areas may be required on a case-by-case basis so that vehicles enter and leave in forward gear.

B.1.6.4 Vehicle access at the back edge of the footway means that emerging drivers will have to take account of people on the footway. The absence of wide visibility splays at private driveways will encourage drivers to emerge more cautiously. Consideration should be given to whether this will be appropriate, taking into account the following:

- The frequency of vehicle movements
- The amount of pedestrian activity
- The width of the footway
- The value of a garden boundary to the street design.

**Emergency Vehicle Access**

B.1.6.5 Well-connected street networks are preferred as no special provision needs to be made for emergency vehicles.

For cul-de-sacs:

- Care needs to be taken to ensure that streets are not blocked by parked vehicles
- separate access for emergency vehicles needs to be provided if the response time would otherwise exceed the values set by the fire and ambulance authorities.

B.1.6.6 Turning areas will be needed at the ends of cul-de-sacs – see sub-section 4B.3.7 for design guidance.

## B.2 STREET CROSS SECTIONS: COMPONENTS

B.2.0.1 The following sections provide the geometric requirements for individual elements of street links between junctions. Designers should build up an overall street cross-section by assembling these components, based on the overall design principles for each link in a network.

B.2.0.2 In particular, values are given for minimum carriageway widths which refer to the minimum space requirements for different types of vehicles to pass, but the actual widths chosen need to take into account other factors such as car parking requirements and horizontal curvature.

Note - Parameters for carriageways also apply to vehicle tracks through Shared Space streets.

### B.2.1 Carriageways and Vehicle Track Space

#### General

B.2.1.1 Carriageway and vehicle track space widths should generally be based on the following considerations:

- The design widths of motor vehicles that will regularly use them.
- Cyclists using the carriageway
- Public transport requirements
- Car parking requirements
- Horizontal curvature
- Trees and planting
- Access for maintenance and renewal of utilities and drainage (see Section 4F.6.0).

B.2.1.2 Carriageway and vehicle track widths do not have to be constant along a street length. Varying the width through non-parallel kerb lines or other physical limits can create interest, provide informal parking opportunities at widening and traffic speed reduction at narrowings. The needs of cyclists at narrowings should be considered in detail however – see sub-section 4B.2.1.0-14 below.

B.2.1.3 The design of local roads should accommodate service vehicles without allowing their requirements to dominate the layout. Larger vehicles which are only expected to use a street infrequently, such as pantechnicons, need not be fully accommodated – designers could assume that they will have to reverse or undertake multipoint turns to turn around for the relatively small number of times they will require access.

B.2.1.4 It is neither necessary nor desirable to design new streets to accommodate larger waste collection vehicles than can be used within existing streets in the area.

#### Minimum carriageway/vehicle track space width - vehicle types

B.2.1.5 Shared Space Streets:

- Vehicle track space width of 3.8 metres, based on one car passing a cyclist, with widened sections of 4.8 metres to enable two cars to pass, approximately every 40 metres maximum.
- In particular circumstances this may be reduced on short stretches to a minimum value of 2.75 metres, which will still allows for occasional large vehicles and discourages drivers trying to squeeze past cyclists. The local Fire Safety Officer should be consulted where a carriageway width of less than 3.8 metres is proposed.

B.2.1.6 Conventional streets with a design speed of 20mph or less:

- Minimum carriageway width of 4.8 metres needed for two cars to pass with some care
- A refuse truck/commercial vehicle will just be able to pass a car at this width.
- Narrowings will be permissible (one way working).

B.2.1.7 Streets with higher design speeds:

- Minimum carriageway width of 5.5 metres, based on two cars passing in comfort
- Two refuse trucks/commercial vehicles will just be able to pass at this width.

B.2.1.8 These minimum widths may need to be increased based on criteria given below. It should also be noted that they are needed to cater for vehicle movement and therefore do not allow for parking and so the minimum widths given will only be acceptable where defined parking bays are provided beyond the carriageway, or where footway parking is physically prevented by some means.

B.2.1.9 Where carriageway widths are less than 6 metres it will be necessary to discourage footway parking by providing defined parking bays beyond the carriageway or by some other means.

#### **Cyclists using the carriageway**

B.2.1.10 Cyclists should wherever possible be accommodated on carriageways without special provision, based on the recommendations of LTN 2/08, *Cycle Infrastructure Design*.

B.2.1.11 Where off-carriageway cycle tracks and on-carriageway cycle lanes are considered appropriate, dimensions are given below in sub-sections [4B.2.2.6-8](#) and [2.3](#) below.

B.2.1.12 Track space widths required for vehicles to pass cyclists in comfort:

- Car passing at 20mph – 3.8 metres
- Car passing at 30mph – 4.3 metres
- Bus/HGV passing at 20mph – 4.6 metres
- Bus/HGV passing at 30mph – 5.1 metres.

B.2.1.13 These are not lane widths, however. In most cases on residential streets traffic flows will be light enough for vehicles to pass cyclists by moving into the opposite lane.

B.2.1.14 On street sections where it is not possible or likely (due to traffic flow or other factors) that vehicles will not be able to move over to avoid cyclists, the above width requirements should be achieved.

#### **Buses**

B.2.1.15 A minimum carriageway width of 6m will be required on streets with a bus service of higher frequency than 60 minutes in each direction.

B.2.1.16 On streets with bus routes of higher frequency than 30 minutes in each direction, running carriageways are to be kept free from parked cars, by providing car parking bays and/or by parking restrictions.

B.2.1.17 The need for widening on bends to cater for buses will need to be considered, as set out in sub-section [4B.2.1.28-32](#).

**On-Street Car Parking**

B.2.1.18 On street parking may be explicitly designed for in the following arrangements:

- 20mph streets - longitudinal, echelon or at right angles
- 30mph streets – longitudinal, but in some circumstances (e.g. in shopping areas) echelon parking may also be appropriate.

B.2.1.19 Dimensions for car parking spaces:

- Longitudinal – 2m wide by 6 metres long
- Echelon and right angle spaces – 5 by 2.5 metres
- Disabled parking spaces – 6.6 by 2.7 metres – see *Inclusive Mobility* for details.

B.2.1.20 Where right angle parking spaces abut footways, a wider footway should be provided or a wheel stop formed 4.5 metres from the outer end of the parking space to prevent vehicles from overhanging and obstructing the footway.

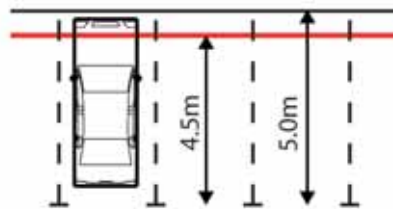

B.2.1.21 Widths required to manoeuvre to/from parking spaces:

- 90° - 6m
- 60° - 4.2m
- 45° - 3.6m
- 30° - 3.6m.

B.2.1.22 Where parking is provided on street, this manoeuvring width will generally be provided by the carriageway.

B.2.1.23 Echelon parking must be arranged so that vehicles reverse into parking spaces.

B.2.1.24 Reductions in the required manoeuvring widths can be achieved by using wider parking spaces. Swept paths analysis can be used to assess the effect of oversized spaces.

**Tracking assessment**

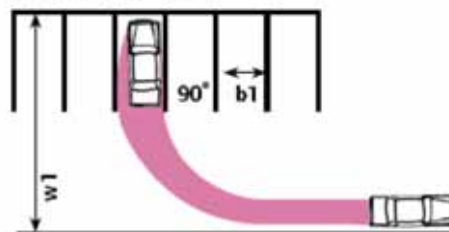

B.2.1.25 Where the end spaces of groups of longitudinal parking spaces are defined by kerbs, the spaces may need to be widened by 0.2m or have a corner radius of 1m at the end of the space, to assist vehicle manoeuvring.

- B.2.1.26 A paved strip of minimum width 0.5 metres will be needed alongside any planted/soiled area alongside the end space or alongside any parking position which is adjacent to garden or planted areas.

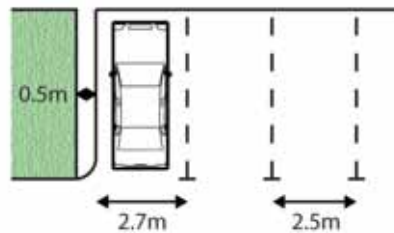

- B.2.1.27 Where longitudinal parking spaces are provided, breaks between spaces should be provided at least every 5 spaces to provide opportunities for pedestrians to cross. This can be achieved using build-outs, which may be at driveways etc. Wherever build-outs are designed as crossing points they should be designed appropriately and include dropped kerbs and blister surface tactile paving. Build-outs will also encourage drivers to park within the protected bays, thus helping to prevent footway parking.
- B.2.1.28 **Carriageway widening on curves**  
Carriageway widening requirements for horizontal curves should be assessed using tracking software, based on the following criteria:
- B.2.1.29 20mph streets mainly serving residential areas:
- Two cars passing on the curve
  - Refuse vehicle using the entire carriageway.
- B.2.1.30 The need for curve widening on principal streets with higher design speeds and serving mixed use areas will be determined on a case by case basis.
- B.2.1.31 On bus routes with a service frequency of more than 60 minutes in each direction, it will be desirable to enable two buses to pass on bends, but this can lead to excessive space requirements. It may be acceptable to provide a lesser width, depending on the number of such locations and their impact on bus operations. Checks will need to be made for adequate intervisibility between sections where carriageway widths only allow for one bus to pass.
- B.2.1.32 Overrun areas adversely affect pedestrian amenity and are not generally desirable.

#### Trees and Other Planting

- B.2.1.33 The space requirements of trees and other planting will need to be taken into account from the outset in the design of the overall street cross section. Further guidance on planning for trees and planting is contained in Section 4G.
- B.2.1.34 Factors to be considered will include:
- The height and spread of the chosen species
  - Space requirements for tree roots
  - The potential impact on utilities
  - Maintenance requirements
  - The acceptability of tree crowns overhanging carriageways and footways
  - The effect of trees on street lighting design
  - The remaining footway width and the minimum standards set in *Inclusive Mobility*.

## B.2.2 Footways and Off-Carriageway Cycle Facilities

### Footways

B.2.2.1 Footways separated from the carriageway by a kerb of 75-100mm height will be required along all streets except Shared Space Streets (see sub-section 4B.1.1.2-7).

B.2.2.2 Footway minimum widths (including kerb width):

- 2 metres along carriageways
- 3 metres at bus stops
- 3.5 to 4.5 metres adjacent to gathering places, outside shops, schools etc.
- Greater widths may be required in locations where pedestrian densities are expected to be particularly high and where there is longitudinal parking
- These widths should generally be free from obstructions, other than localised items such as street lighting columns, although short localised reductions in width may be acceptable, in accordance with advice contained in the DfT's *Inclusive Mobility*
- Trees and planting should not adversely affect the use of footways.

B.2.2.3 Dropped kerbs should be provided at all junctions and crossing points, and tactile paving should be provided in accordance with the DfT's *Guidance on the Use of Tactile Paving*.

B.2.2.4 Ramps and steps should be provided as alternatives to each other, and be designed in accordance with inclusive design standards in order to accommodate the maximum number of pedestrians, including wheelchair and scooter users, blind and partially sighted people and ambulant disabled people.

B.2.2.5 Further guidance on the design of steps and ramps on pedestrian routes is given in *Inclusive Mobility*.

### Off-carriageway cycletracks and shared footway/cycletracks

B.2.2.6 These should not normally be required in residential streets but may be required in non-car links. Where cycletracks are used, there should always be a distinct feature separating the cycle and pedestrian tracks to meet the needs of visually impaired people. Features might include a level difference ('step down to danger'), soft landscaped area or barrier.

B.2.2.7 Minimum widths:

- Two-way Cycletrack not intended for pedestrian access – 2 metres
- Shared Footway-Cycletrack - minimum widths based on the recommendations of draft LTN 2/04.

B.2.2.8 Off-carriageway footway/cycletracks should by default be a single surface but with a distinct feature separating the cycle and pedestrian tracks to meet the needs of visually impaired people. Features might include a level difference ('step down to danger'), soft landscaped area or barrier.

## B.2.3 Cycle Lanes

B.2.3.1 The need for on-carriageway cycle lanes should be assessed in accordance with the guidance contained in LTN 2/08, *Cycle Infrastructure Design*. Cycle lanes may also be warranted where cycling is to be encouraged to key destinations within an overall movement strategy.

B.2.3.2 Generally, one-directional cycle lanes should be:

- Desirable minimum width – 1.5 metres
- Absolute minimum width – 1.2 metres.

### B.2.4 Soft Verges

B.2.4.1 Soft verges may be used to separate footways or cycletracks from carriageways. Minimum widths of verges will depend on the type of planting and maintenance requirements, as set out in Sections 4G and 4J but should not generally be less than 1.5 metres.

### B.2.5 Centreline Markings

B.2.5.1 20mph streets and below: no centreline markings are required.

B.2.5.2 30mph streets: centreline markings may be omitted unless local circumstances require drivers to be given a clear indication of the through route beyond that which derives from kerb lines and building edges.

### B.2.6 Bus Stops

B.2.6.1 The location of new bus stops and all bus infrastructure needs to be planned in consultation with SYPTE, who will provide detailed requirements, the local highway authority and the Police to ensure suitable locations are selected. Where bus services operate in both directions, any new bus stops should be provided in pairs and staggered tail to tail.

B.2.6.2 On local residential streets stops should be located within the carriageway to allow buses to rejoin traffic easily, prevent car overtaking and allow pedestrians alighting the bus to cross the road easily. Bus lay-bys will only be used in limited circumstances, notably on routes with high traffic speeds and flows.

B.2.6.3 Adequate waiting facilities, shelters with seating with backs and arm rests, raised kerbs with platform edge and guidance paving and bus service information, including the provision of real time information, should be provided in a well lit area in accordance with *Inclusive Mobility*. The adopted arrangement of guidance surface and platform edge (on street) warning surface tactile paving should be provided.

B.2.6.4 Detailed design information on bus stops will be provided by SYPTE.

## B.3 JUNCTIONS

### B.3.1 Junction Spacing

B.3.1.1 20mph and below streets - no minimum junction spacing will apply.

B.3.1.2 On streets with higher design speeds, the following minimum junction spacings will generally apply,

- Same side – 40 metres
- Opposite side – 20 metres.

### B.3.2 Footway Crossovers

B.3.2.1 Footway crossovers maintain pedestrian provision across the mouth of minor junctions, creating an environment where drivers consider they are moving across a space where pedestrians can expect to have priority.

B.3.2.2 Footway crossovers are suitable for serving minor accesses to dwellings and commercial premises: Acceptable peak vehicle flows should be agreed with Highway and Access officers. Guide figures are as follows:

- Up to 100 vehicles per hour from 20mph streets.
- Up to 50 vehicles per hour from 30mph streets

B.3.2.3 Visibility splay requirements at footway crossovers are as for T- and Y- junctions. No tactile paving is required at footway crossovers, however, the kerb should not be dropped lower than a 25mm so that a detectable kerb up stand is maintained.

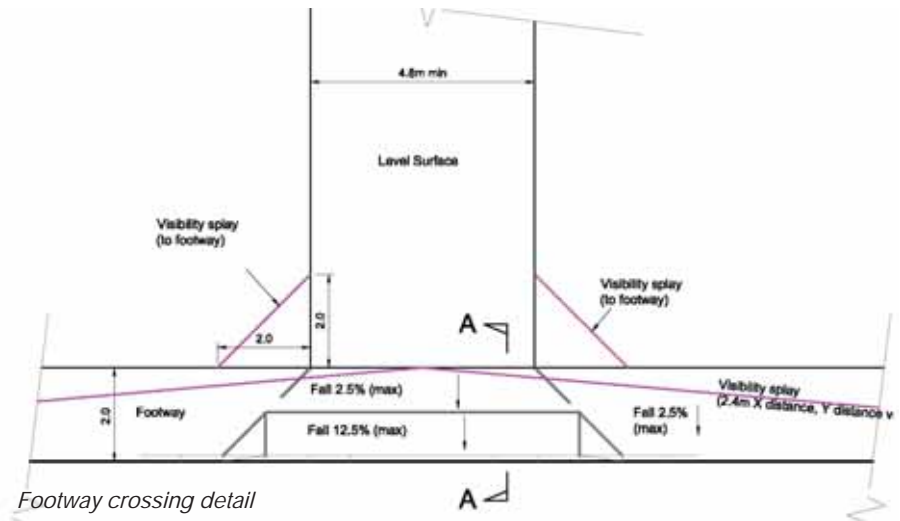

B.3.2.3 Where crossovers are formed, normal footway crossfall should be maintained for at least 900mm from the back of footway.

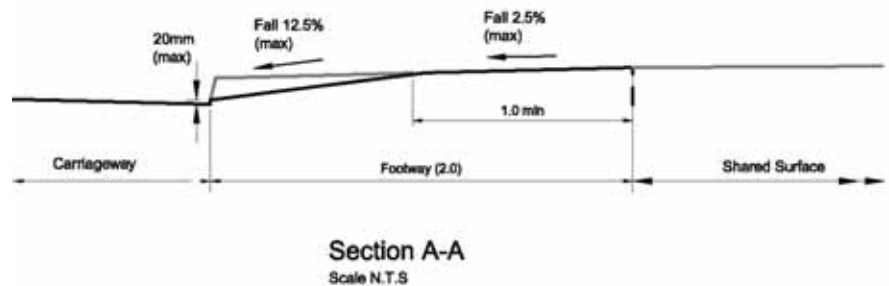

**B.3.3 T- and Y- Junctions**

(For crossroads junctions refer to sub-section 4B.3.5)

**Visibility Splays**

B.3.3.1 Minimum visibility splays at T- and Y- junctions are as set out in Section 7.7 of *Manual for Streets*.

B.3.3.2 Traffic capacity considerations may require increased visibility splays, however, and when directed by the highway authority, capacity assessments will be required for T-junctions which will consider, amongst other factors, visibility splay provision. Parked vehicles in bays should not interfere with visibility splays.

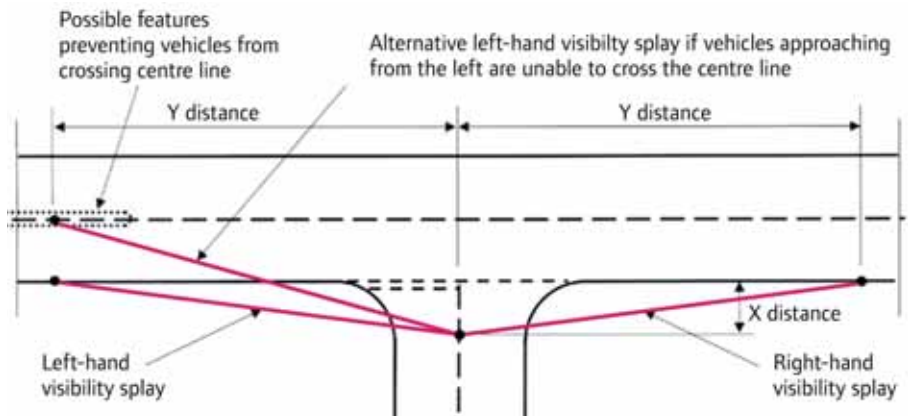

**Tabled footways across minor arms**

- B.3.3.3 Tabled footways across can be used to denote a change in character between a main and a more minor route. They also provide for easier pedestrian movement by enabling people to cross on the level and by slowing vehicle speeds with vertical deflection. They are similar to footway crossovers, but create a space where priority is shared, rather than being perceived as a pedestrian space.
- B.3.3.4 The kerb should be flush with the raised table for the full width of the table.
- B.3.3.5 Tabled footways may be used on all routes where the side road traffic flows are less than 300 vehicles per hour.

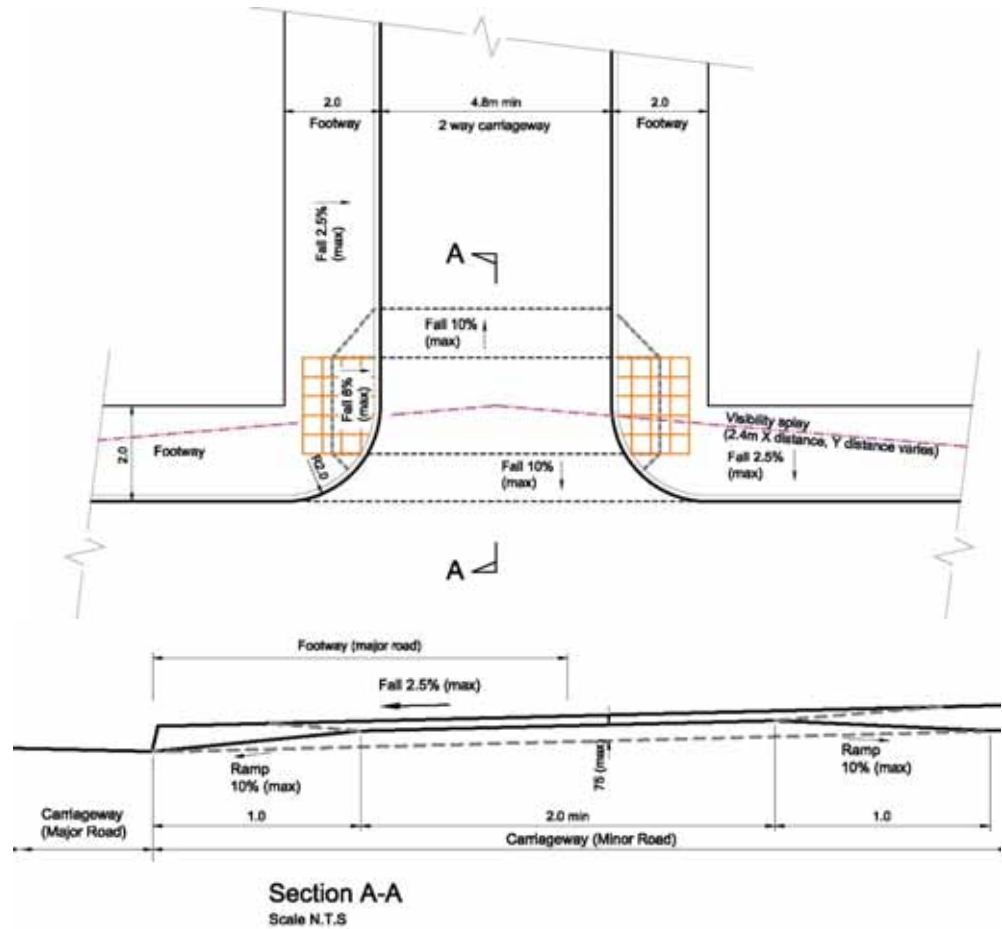

Note – tabled footways across minor arms are most suitable with corner radii of 3 metres or below.

**Priority Markings**

- B.3.3.6 When the major arm has a design speed of 20mph and below, no priority markings or give way signs will be required at T-junctions:
  - Where the minor arm is a footway crossing or has a tabled footway
  - In other situations when the maximum average peak hour 2 way flow on any arm does not exceed 300 vehicles per hour.
- B.3.3.7 When the major arm has design speed of 30mph, no priority markings or give way signs will be required at T-junctions:
  - Where the minor arm is a footway crossing or has a tabled footway.

**Corner Radii**

B.3.3.8 Minimum corner radii at junctions depend on traffic speed on the major arm, traffic flow on the minor arm, together with vehicle tracking considerations (see below). As far as possible minimise corner radii in order to reduce speeds and create safer crossings for pedestrians.

Major arm speed	Average 2-way peak hour traffic flow on minor arm	Minimum corner radius
<20mph, Shared Space Street	< 100 vph	None
20mph	< 100 vph	None
	> 100 vph	2m
30mph	< 50 vph	None
	> 50 vph, < 300 vph	3m
	> 300 vph	6m

**Vehicle Tracking Considerations**

B.3.3.9 The minimum radii given above should be considered in conjunction with vehicle tracking requirements since the ability of vehicles to turn at T- and Y- junctions is dependent on the combination of corner radius and carriageway width.

B.3.3.10 Track tests should be carried out for vehicles turning left into and out of the minor arms of junctions using tracking software, based on the following criteria:

B.3.3.11 Junctions on streets with design speeds of 20mph and below:

- refuse vehicles able to turn with the vehicle body leaving a 0.5 metres clearance to the carriageway edge on both the major and minor arms.

B.3.3.12 Junctions with 30mph streets:

- design vehicle to be determined based on local land use considerations.
- Where the average 2 way peak hour traffic flows on both the major and minor arm are less than 500vph, the design vehicle should be able to turn with the vehicle body leaving a 0.5 metres clearance to the carriageway edge on both the major and minor arms.
- Where average peak hour 2 way traffic flow on the major arm exceeds 500 vph, the design vehicle should be able to turn without crossing into the opposing lane on the major arm.
- When the average peak hour 2 way traffic flow on both arms exceeds 500 vph, the design vehicle should be able to turn without crossing into the opposing lane on both arms.

**B.3.4 Informal Squares**

B.3.4.1 Informal squares may be used within streets designed to 20mph and below where several streets meet. The following features are desirable:

- Tabled footways with flush kerbs and blister surface tactile paving across the carriageway at each entrance to the square and low kerb elsewhere (height to be agreed with highway and access officers)
- Change of material on the entrance to the square
- Corner radii of 2 metres or less on the entrance to the square

- No marked priority within the square
- Parking within the square
- Additional physical features such as trees or bollards may be required to define vehicle tracks through the square or corners.

B.3.4.2 Carriageways may be raised to footway level on entrances to the square, but where this is done it will be necessary to prevent vehicles overrunning footways by using suitable street furniture, trees or planting.

### B.3.5 Crossroads

B.3.5.1 Crossroads junctions (not controlled by traffic signals) are acceptable in the following situations:

B.3.5.2 On 20mph and below streets

- when the average peak hour 2 way flow on any arm of the junction is less than 100 vehicles per hour.

B.3.5.3 On 30mph streets where the side arms are designed to 20mph and below:

- When the average peak hour 2 way flow on the busiest minor arm is less than 50 vehicles per hour.

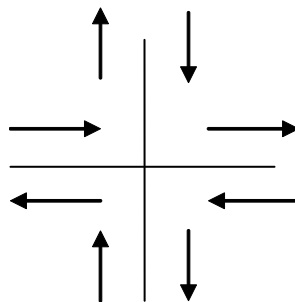

20 mph on all approaches  
Maximum 2 way flow on any arm 100 vph

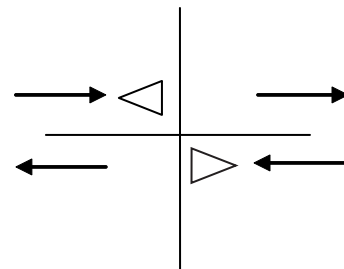

20 mph on minor arms  
Maximum 2 way flow on minor arm 50 vph

B.3.5.4 Crossroads junctions between 30mph streets will not normally be acceptable.

B.3.5.5 Visibility splays, corner radii, provision of tabled footways across minor arm and junction tables criteria are as for T- and Y-junctions.

B.3.5.6 Crossroads junctions on 20mph streets may be unmarked. In addition to crossroads, there are a number of different ways to accommodate uncontrolled four arm junctions within a layout. Examples include creating a central space or 'square' into which all the arms lead, raising the junctions space as a table or creating a minor stagger. For further detail see *Manual for Streets* 7.3.10 (and Figure 7.12).

### B.3.6 Roundabouts

B.3.6.1 As noted in *Manual for Streets*, conventional roundabouts are not generally appropriate for residential developments. Mini-roundabouts may be used within residential areas at 3 and 4-arm junctions where flows are reasonably balanced, and provide an alternative to crossroads junctions, with and without priority. However, signage and road markings are needed at mini-roundabouts, they can be intrusive in visual terms and therefore the use of mini-roundabouts is generally to be avoided.

B.3.6.2 Further guidance on the design of mini-roundabouts is contained in *Mini-Roundabouts – Good Practice Guidance* published by DfT and the County Surveyors Society.

### **B.3.7 Turning Areas**

- B.3.7.1 Turning areas should be avoided where possible by the use of well-connected street networks.
- B.3.7.2 Where culs-de-sac do form part of the street pattern, they will need to be designed as necessary with a turning area to accommodate the largest vehicle that will regularly require access.
- B.3.7.3 Depending on waste collection requirements, this is likely to be a refuse truck which has a wheelie-bin lifting facility.
- B.3.7.4 Where refuse trucks do not need to enter the cul-de-sac, turning areas should be designed to accommodate a fire appliance.
- B.3.7.5 Standard turning heads are not provided in this technical guidance – turning areas should be designed to suit the particular local environment as simple turning heads are unattractive. To be effective and usable, the turning head must be clear of parked vehicles and therefore it is essential that adequate parking is provided for residents in the local area.
- B.3.7.6 Any boundary, fence or hedge should be set back at least 0.5m from the carriageway, and 2m at the ends of culs-de-sac to avoid damage resulting from the overhang of manoeuvring vehicles. The space between the kerb and highway boundary must be paved and maintained as public highway.

## **B.4 SPEED RESTRAINT**

### **B.4.1 General Principles**

- B.4.1.1 Design speeds for streets are given in sub-section 4B.1.2.
- B.4.1.2 For streets with a design speed of below 30mph, speed controlling features will generally be required at the following spacings, which should allow for some flexibility:
- 25mph – 100 metres
  - 20mph – 70 metres
  - Less than 20mph – 40 metres.
- B.4.1.3 Speed restraint will also be assisted by physical features and psychological factors along links such as:
- Narrow carriageway widths in association with building layout
  - Close proximity of buildings to the street
  - Street trees
  - On-street parking
  - Pedestrian activity
  - Omission of centreline markings
  - Textured carriageway surfaces and marginal strips
  - Not providing excessive forward visibility for drivers
  - Simple vertical deflections should be avoided.
- B.4.1.4 Individual speed controlling features will not generally be required on 30mph streets, but the types of features listed above should be provided wherever possible to help deter excessive traffic speeds.

## B.4.2 Speed Restraint Features

### Limiting forward visibility

- B.4.2.1 On 20mph and below streets, layouts may incorporate features to limit forward visibility for drivers along links. This can be achieved by using buildings, planting or other features such as public art, possibly in combination with changes in vertical alignment. Minimum visibility requirements in accordance with sub-section 4B.1.3 will still apply however.
- B.4.2.2 Any localised reduction in forward visibility for drivers will need to be balanced with the need for pedestrians to see sufficiently far along streets to find their way easily.

### Carriageway narrowings

- B.4.2.3 Carriageway narrowings are most effective and acceptable when they are designed as an integral part of the street scene rather than an artificial add-on. Design criteria are as follows:
- Vehicle priority should generally not be marked at narrowings
  - Minimum width: 3.25 metres over short lengths of 10 metres or less
  - Minimum width: 3.8 metres on longer sections and where cars need to pass cyclists on 20mph routes
  - Longer sections on 30mph routes require cycle bypasses
  - A minimum operating space of 3.7 metres should be provided for fire appliances
  - Dropped kerbs to encourage pedestrians to cross at narrowings should be provided
  - Trees and planting may be incorporated in the narrowing and can help to emphasise the speed reducing effect
  - Designers should be aware of the space requirements of drainage and services.

### Junctions

- B.4.2.4 Junctions where traffic streams lose priority or share priority with other movements act as speed restraint features:
- T- and Y- junctions (minor arm)
  - Crossroads with priority markings (minor arms)
  - Crossroads with no marked priority (all arms)
  - Informal squares
  - Mini roundabouts
  - Roundabouts with raised central islands.

### Bends

- B.4.2.5 Sharp changes of direction will act as effective speed reducing measures. Minimum radii are as follows:
- Streets with a design speed of 20mph or below - no minimum horizontal radius
  - On streets with a design speed of 30mph when the curve radius is less than 35m, care needs to be taken to ensure that speeds are reduced locally on the approach to around 25mph to prevent loss of control. With this proviso, a minimum bend radius of 10m may be used.
- B.4.2.6 With all bends, track testing should be carried out as described in sub-section 4B.2.1.28-32 above.

### Junction tables

- B.4.2.7 T- and Y- junctions may be tabled on both 20mph and 30mph streets to assist pedestrian movement and to reduce traffic speed at the junction, subject to features being incorporated to prevent overrunning of the footways.

The excessive use of vertical deflections to control speeds can be problematic, however, due to noise and vibration impacts. Vertical deflections should not normally be used on bus routes.

Desirable parameters:

- Maximum table height – 75mm
- Maximum ramp gradient – 1:20 relative to carriageway gradient
- Corner radii of 2m or less at entrance to square
- Material change on junction table
- Absence of junction priority markings, subject to guidance in [sub-sections 4B.3.3.3 and 3.5](#)
- Minimum kerb height (to be agreed with highway and access officers) retained, except at crossing points where flush kerbs and blister surface tactile paving provided.

The Highways (Road Hump) Regulations (1996) will apply to Junction tables.

### B.4.2.6 Tabled Pedestrian Crossings

Pedestrian crossings at footway level, with carriageway ramps on either side, provide speed control measures as well as facilitating key pedestrian movements.

Similar design criteria to the Junction tables apply to tabled pedestrian crossings.

### B.4.2.7 Round-Topped Humps

Round-topped humps are the least desirable form of speed restraint and should only be used where no other option is available.

## 4C Drainage

### C.1 General

- C.1.1 The use of sustainable drainage systems (SuDS) is advocated by the Local Authorities and Yorkshire Water where it can be demonstrated SuDS are acceptable.
- C.1.2 In accordance with the Flood and Water Management Act 2010, the plans for all SuDS proposals, whether permitted development or requiring planning permission, must be approved by the SuDS Approving Body (the unitary authorities) prior to the start of construction. The Environment Agency may also need to be consulted.
- C.1.3 It is essential to involve the adopting authorities (land drainage, highway, highway structures and water) as early as possible to discuss any proposals.
- C.1.4 Key considerations for the use of SuDS include:
- General drainage impact and flooding
  - Ground and groundwater conditions
  - Interaction with foul sewers
  - Rights of discharge
  - Long term inspection and maintenance requirements.
- C.1.5 The general approach to SuDS should use a 'management train' that follows the natural pattern of drainage, including:
- Prevention – reduce runoff from individual sites (for example, by reducing paved areas)
  - Source control – include features that retain runoff at or near the source
  - Site control – route water from sub-catchments to larger, common features.
- C.1.6 Potential components of SuDS include but are not limited to the following:
- Green roofs
  - Rainwater harvesting systems
  - Pervious surfaces
  - Filter drains
  - Filter strips
  - Swales
  - Retention or balancing basins, ponds and wetlands
  - Infiltration basins, trenches and soakaways
  - Bioretention areas
  - Attenuation/retention tanks or systems.
- C.1.7 New developments must be provided with separate on-site systems of drainage. No discharges from property can be accepted into highway drains.
- C.1.8 Surface water from the highway shall be collected by means of gullies and gully connections, channel and grating systems or combined drainage and kerb systems and discharged through pipes of not less than 150mm diameter to an adequate SuDS feature, sewer, highway drain, ditch or watercourse.
- C.1.9 The drainage system for the whole development must include retention and filtering features as necessary to meet required runoff rates and water quality standards as determined by the Environment Agency/Land Drainage Authority. It is the Developer's responsibility to provide sufficient evidence, including a Drainage Impact Assessment or Flood Risk Assessment as necessary, to demonstrate that downstream watercourses, culverts or pipes will not be adversely affected.

- C.1.10 Where it is proposed to connect to an existing or proposed public sewer, the consent of the appropriate Water Undertaker will be required, and the Highway Authority will require evidence that such consent has been obtained prior to approving the drainage design. adoption agreement. Before adoption by the Highway Authority all drainage systems must be cleaned out and a CCTV inspection provided.
- C.1.11 Whenever feasible one surface water pipe (being a Section 104 prospective public sewer) shall be laid in the highway taking discharge from properties and the highway. Any lengths of surface water pipework receiving only discharge from the highway shall be designated highway drains, being included within a Section 38 adoption agreement. Before adoption by the Highway Authority all drainage systems must be cleaned out and a CCTV inspection provided.

## **C.2 Maintenance and adoption of SuDS**

- C.2.1 Subject to agreement, the Local Authority/Land Drainage Authority/Highway or Water Authority will consider for adoption filter drains, pipework, filter strips, swales, retention or balancing basins, ponds and wetlands, infiltration basins, trenches and soakaways and bioretention areas.
- C.2.2 The use of pervious surfaces, attenuation/retention tanks or other infiltration/storage systems will not normally be accepted on adoptable carriageways or footways as they could effectively sterilise the highway for other statutory services and create a future consequential highway maintenance liability. The installation of hard SuDS solution may be appropriate under private car parks, driveways, gardens or public open spaces.
- C.2.3 The adopting authority will require independent validation that the SuDS has been constructed in accordance with good practice and follows the submitted design. The validation must also indicate that the system is in an acceptable condition for handover. Before handover the SuDS will have to be inspected and any identified remedial works completed.
- C.2.4 An owner's manual must be provided to the adopting authority by the developer that includes a maintenance plan that properly addresses both the initial and ongoing maintenance of the SuDS facilities. and shall specify any consequential highway maintenance needs associated with the provision of the SuDS facility, accounting for compliance with CDM Regulations 2007 and the potential impact it has on other utility services located in the vicinity of the SuDS. The plan must cover the following stages as appropriate to the components:
- Initial construction and planting
  - Intensive management to allow establishment
  - First de-silting (especially on new developments during construction phase)
  - Maintenance (routine annual and major maintenance)
  - Rehabilitation.
- C.2.5 The design of SuDS should make possible safe and convenient access by personnel and construction equipment to undertake maintenance tasks. The manual must also include a plan showing the incoming/outgoing drainage systems together with labels showing responsibility and land ownership details
- C.2.6 In the context of seeking to create multi-functional landscape features, it is important to give priority to the proposed maintenance regime of SuDS features over other uses to avoid compromising the effectiveness of the features. The creation or enhancement of any wildlife habitat as a result of the SuDS must take into account potential impacts on the maintenance requirements. In most cases, however, the maintenance of SuDS is compatible with the presence of wildlife.

C.2.7 If adopted, commuted sums will be required for the maintenance of each SuDS component. Where SuDS are to remain un-adopted, the developer must provide confirmation as to who will be responsible for the system's future maintenance.

### C.3 The design of SuDS components

- C.3.1 Because of the diversity and flexibility of sustainable drainage systems it is not possible to provide comprehensive guidance on the design of SuDS in this document.
- C.3.2 For components such as green roofs, rainwater harvesting systems and pervious surfaces, guidance is best sought from providers of proprietary systems or independent organisations such as The Green Roof Centre or Living Roofs.
- C.3.3 For components such as:
- Filter drains
  - Filter strips
  - Swales
  - Retention or balancing basins, ponds and wetlands
  - Infiltration basins, trenches and soakaways
  - Bioretention areas,
- C.3.4 Please consult, amongst others, the CIRIA publication C609 *Sustainable drainage systems – hydraulic, structural and water quality advice* (Wilson et al, 2004) , C687 *Planning for SUDS - making it happen* (Dickie, S, et al, forthcoming). *Design Manual for Roads and Bridges*, HA103/01 *Vegetative treatment systems for highway runoff* (HA et al, 2001) as well as the Building Regulations, Part H.
- C.3.5 Certain hard SuDS may be classed as highway structures in which case technical approval for the design and future maintenance of the system shall be required from the Highway Authority.
- C.3.6 The location of SuDS features must take into account the following considerations:
- Ground conditions and hydro-geological factors
  - Possible future flooding
  - Access and the need for easements
  - Maintenance of the SuDS and if placed in the highway, the consequential maintenance of the highway asset in which it is located
  - Distance from dwellings, current and future tree planting, carriageways, services, sensitive aquifers, adjacent landfills/contaminated land etc.
- C.3.7 An EA 'consent to discharge' is required to discharge effluent (which includes surface water) to controlled waters. The EA should be contacted at the design stage of a development to establish whether there is a need for a licence.
- C.3.8 The EA's 'Policy and Practice for the Protection of Ground Water' includes policy statements on discharges to underground strata and should therefore be utilised when considering discharge to soakaways. Highway drainage to soakaways may be opposed in aquifer protection zones around public water supply boreholes.
- C.3.9 Additional site investigation, ground improvement and special design requirements must be considered where solution features or 'made ground' are encountered local to soakaway chambers and inlet pipes. Under these geological conditions design requirements for inlet pipes include increased pipe flexibility and increased gradients to allow for future differential settlements.

#### C.4 Ditches and watercourses

- C.4.1 The EA/Internal Drainage Boards/Local Authorities and riparian land owners should be consulted as to whether or not ditches or watercourses on development sites are to be piped or culverted.
- C.4.2 In accordance with current environmental policies, it is preferable to retain open watercourse channels wherever possible. Any culverting or diverting of watercourses must obtain approval from Local Authorities under Section 263 of the Public Health Act 1936, in addition to any approval from the Environment Agency. Culverts must be sized to take the maximum possible discharge created by extraordinary rainfall, this can be taken as an event with a 1 in 100 year storm.
- C.4.3 If culverting of a watercourse is accepted, the new culvert (new or occasionally, if agreed, an existing) will normally form a crossing of the highway. Where it is proposed that the Highway Authority takes responsibility for watercourse culverts or pipework laid longitudinally within the highway, then a commuted sum may be payable to the Highway Authority. Alternatively the watercourse pipework can be routed through private property, in which case the riparian responsibilities must be covered in the property deeds. The adoption of any watercourse, whether open or culverted by the Adopting Authority must be clearly included in the Section 38 Agreement.

#### C.5 Design of highway drainage systems

- C.5.1 Construction and design standards, except when noted below, will generally comply with the latest edition of *"Sewers for Adoption (currently 6th edition)."*
- C.5.2 The 'Modified Rational (Lloyd-Davies)' method or 'Micro Drainage Computer Analysis' shall be used for the design of highway drainage as set out in Road Note 35 'A guide for engineers to the design of storm sewer systems', published by HMSO and used in conjunction with the 'Tables for the hydraulic design of pipes and sewers (Latest Edition – Currently 8th Edition)', published for Hydraulics Research by Thomas Telford Ltd. Refer to the 1 in 30 year criteria.
- C.5.3 The following parameters shall be used:
- The system must be capable of accepting without surcharge a storm frequency of once every 2 years except for sites where consequences of flooding are severe, for example, existing basement properties adjacent to new developments, where a frequency of once every 30 years will apply
  - The system must be capable of accepting a storm frequency of 1 in 30 years without the occurrence of ground level overflow. The system should ensure no flooding to any buildings (existing or proposed, on or off site) created by a 1 in 100 year event (reflective of climate change). Water generated by events between 1 in 30 and 1 in 100 years should as far as is reasonably practical, be stored on site in car parks or landscape areas. Any flood routes up to 1 in 100 years (+CC), particularly if they go off site must be clearly shown.
  - Time of entry - normally 2 minutes
  - Minimum self-cleansing velocity - 1.0 m/sec
  - Limited use of short lengths of steep gradients are preferred to the use of backdrops
  - Impermeability factor - 1.0 over whole width of highway (including footways and verges)
  - Roughness coefficient of pipes - 0.6mm.
- C5.4 The following formula shall be used in calculating the rate of flow:
- $$Q(\text{litres/sec}) = 2.78 \times R \times A_p$$
- where R is the rainfall in mm/hr and  
A<sub>p</sub> is the cumulative impermeable area in hectares.

- C.5.5 To assist in the checking of drainage calculations a design sheet based on Table 1 of Road Note 35 should be used, or alternatively 'Microdrainage' or similar approved computerised programs should be submitted.
- C.5.6 Highway drains up to and including 900mm diameter, including gully connections and sewers, shall comply with BS EN 752 (2008) (formerly 8005). The type and class of both pipe and bedding, which shall be determined by the ground conditions, the proposed cover to the pipe, the design loading and trench width, must be shown on the drawings. Calculation of design loads and bedding factors shall be in accordance with the Simplified Table of External Loads on Buried Pipelines, issued by the Building Research Station and published by HMSO. All calculations for design loads shall be submitted for approval.
- C.5.7 Highway drains and piped connections should have a minimum diameter of 150mm, with 225mm being the minimum diameter serving 12 gullies or more.
- C.5.8 Highway drains and sewers greater than 900mm diameter are classified as highway structures and will require Technical Approval as defined in [Section 4D](#).
- C.5.9 Gullies should preferably connect directly into manholes, but if this is not possible they shall be connected to the main pipe by means of 45° oblique angled junctions and surrounded by concrete mix ST4. Gully connections shall not normally be longer than 20m and serve no more than four gullies.
- C.5.10 Each gully shall not drain more than 200m<sup>2</sup> of catchment area. Double gullies should generally be provided at low points.
- C.5.11 When calculating areas drained, allowance must be made for all footways/driveways, footpaths, paved areas and highway verges which fall towards the carriageway. Forecourts in excess of 50m<sup>2</sup> should have separate systems, unless agreed with the Highway Authority. Where appropriate, designers should also consider the possibility of further development beyond the site boundary in determining the capacity of new networks.
- C.5.12 In footpaths which are separated from carriageways, gullies or channels connected to the highway drainage system must be provided where surface water would otherwise pond or discharge into adjacent property or down a flight of steps.
- C.5.13 Gullies should be sited to prevent surface water flowing across the junctions. Care should be taken to eliminate ponding in the vicinity of the mid-point of the radius kerbs. Where super-elevation is provided, a gully should be sited just short of the point where adverse camber is removed to prevent water in the upstream channel flowing across the carriageway. Care should be taken to avoid ponding in the transition length when the longitudinal gradient is flat or where there are traffic islands, central reserves or traffic calming measures. Gullies must not be sited directly at pedestrian crossing points and gullies sited at driveways and accesses should be avoided where practical.

## C.6 Soakaways

- C.6.1 Soakaways will not be permitted under carriageways or footways.
- C.6.2 Highway soakaways (where acceptable) shall be situated the following minimum distances from dwellings, (measured from the outside edge of a soakaway):
- 5 metres for conventional perforated soakaway
  - 10 metres for deep soakaway
  - Adjacent soakaways should be spaced a minimum of 10 metres apart, otherwise the combined capacity must be reduced to allow for interaction between the soakaways.

- C.6.3 Perforated manholes with stone surround must be used to facilitate storage volume and maintenance voids filled with stone/hardcore will not be acceptable.
- C.6.4 Catchpits shall be provided before the connection to a soakaway. In addition, the EA may require the inclusion of oil interceptors. In all cases the EA must be consulted. The drainage system shall be jetted and catchpits cleaned out prior to adoption to remove silt generated during the construction phase.
- C.6.5 Soakaways shall be designed and installed generally in accordance with BRE Digest 365 *Soakaway Design* (including such revisions as may be issued at the time of signing the Agreement) except that the design must be for a 30 year event. Catchment areas shall not exceed 3,500m<sup>2</sup> for an individual chamber or bank of interconnected chambers. Percolation tests are required to be carried out in the presence of the Highway Authority at the Planning Application stage and these must be undertaken during a wet season when the ground water table is at its highest.
- C.6.6 It may be necessary to link soakaways with at least 150mm overflow pipes when soakage is poor, and at low points overflow pipes should be provided whenever possible. Alternatively, deep borehole type soakaways may be considered suitable, subject to EA approval and any other relevant approvals.

## **C.7 Connection to sewers and drains**

- C.7.1 A new highway drain may be connected to an existing surface water or combined public sewer, or a sewer which is the subject of a Section 104 Agreement under the Water Industry Act 1991, subject to the approval of the Water Authority, who may wish to make the connection to the existing public sewer. A new highway drain may also be connected to an existing highway drain or land drain, subject to the approval of the Highway Authority and other relevant Authorities. In all cases, existing sewers or drains shall be properly extended, connected and jointed to new sewers, drains or manholes and the approval for the connection shall be subject to the determination of adequate excess capacity in the existing drain, sewer or water course.
- C.7.2 In some cases reinstatement of land drains may be required but, where they are to be connected to a sewer, a catchpit shall be provided before the connection, having a silt trap 600mm below the lowest pipe invert. In the case of all other drains they shall be connected in such a way that normal access for the rodding and maintenance is achieved.
- C.7.3 Before entering or breaking into an existing sewer or drain, notice shall be given to the Drainage Authority responsible for the pipe to which the connection is to be made and appropriate permission obtained.
- C.7.4 Where a new highway drainage system is connected to an existing piped system a temporary catchpit may be required while the site is being developed, with the catchpit to be removed on completion of all works and the chamber to be made good with the necessary channels and benching.
- C.7.5 The removal of detritus from chambers, repairs or defects or re-cleaning of the whole or part of a section will be instructed by the HA as additional works where necessary. Detritus must not be allowed to enter any downstream pipework.

**C.8 Outfalls and headwalls**

- C.8.1 Where a piped system discharges into an existing ditch or watercourse the pipe invert shall not be lower than the level of the average flow in the ditch or watercourse and under no circumstances less than 300mm above the ditch or watercourse invert.
- C.8.2 The end of the pipe shall be directed so as to discharge at an angle not greater than 60° to the direction of flow in the ditch or watercourse. The end of the pipe shall be provided with a headwall and apron of a design to support the bank above and adjacent to the pipe and to prevent scouring underneath the pipe. The banks of the ditch or watercourse shall be protected from scouring. In some cases, pitching to the stream bed may also be required. In all cases the EA and other Land Drainage Authorities shall be consulted and any of its requirements shall be complied with.
- C.8.3 Further details can be obtained from CIRIA (Construction Industry Research and Information Association) document entitled "The Culvert Design - CIRIA Report No. 168". The outfall structure shall be in accordance with the latest recommended layout design published by the EA and the developer shall furnish all necessary structural calculations for the design.

**C.9 Drainage structures approval**

- C.9.1 Any drainage chamber, other than manholes using standard pre-cast concrete rings plus concrete surround, together with all pipes greater than 900mm diameter and headwalls greater than 1.0m retained height will require Technical Approval as defined in [Section 4C](#).

## 4D Highway structures

### D.1 Definition of a Highway Structure

D1.1 The definition of a highway structure can fall into one of two types, either:

- Any structure or building built in, under, or over, the highway where the span dimension at any point is equal to, or exceeds 1.0m. This includes amongst others, bridges, footbridges, culverts, pipes, tunnels, chambers, cellars, shafts, manholes and storm water balancing tanks etc. or
- Any structure or building built in - or within 3.66 metres of - the highway, which supports the highway, or ground above it and regardless of the retained height that if it were to fail would, in the view of the Highway Authority, endanger users of the highway. This includes amongst others, retaining walls, headwalls, basements and cellars etc.

D.1.2 The definition of 'highway' used above includes the carriageway, footway and all verges. Structures that fall below the above classification stated in 1.1 including screen walls should be designed to the appropriate standards. For guidance the Highway Authority should be consulted and the relevant information sheets obtained.

### D.2 General

D.2.1 As far as possible embankments should be used to avoid the use of supporting retaining walls. The Highway Authority will only consider adopting walls constructed to support the highway if an embankment is not practicable. All retaining walls over 1m retained height, supporting:

- a) Highways will normally be adopted subject to satisfying the approval procedures
- b) Adjacent land will not normally be adopted but must still meet the approval procedures. The Highway Authority will enjoy the right of support from the adjacent land.

D.2.2 All structures associated with the highway (whether adopted or not) will be required to be designed in accordance with the Eurocodes, Codes of Practice and complementary information contained within the Design Manual for Roads and Bridges (DMRB).

D.2.3 Because of the important design, safety, inspection and maintenance considerations involved it is required that a technical approval procedure must be adhered to for highway structures. Full details of the approval procedure including a schedule of all the relevant design documents is available on request from the Highway Authority.

D.2.4 All structures/walls should be identified on the layout drawing and cross sections and submitted as part of the Planning Application.

D.2.5 The technical approval procedure is based on DMRB BD 2 'Technical Approval of Highway Structures on Motorways and Other Trunk Roads' and is outlined below. The Technical Approving Authority is the Highway Authority.

D.2.6 This approval procedure is to be followed for the construction or alteration of any highway structure, whether to be adopted or not. Where a structure is to be adopted by the Highway Authority this must be specifically written into the Section 38 or 278 Agreement together with the agreed commuted sum figure for future maintenance which the Developer is to pay to the Highway Authority. Where the structure is not to be adopted and does not belong to a Statutory Undertaker, the Highway Authority should be advised of its ownership in respect of future liability.

### D.3 Technical Approval of Design

#### D.3.1 Approval in principle (AIP)

For all highway structures the Approval in Principle document and the Technical Approval Schedule (TAS) will be issued by the Highway Authority to the developer requiring the basis of the design to be defined. The Developer will be responsible for preparing and submitting the AIP.

#### D.3.2 Structure design

Two signed copies of the AIP are to be submitted to the Highway Authority and no design should commence until approval of the AIP has been obtained from the Highway Authority. Upon receipt of the endorsed AIP document the design of the structure may then commence.

#### D.3.3 Design/check certificate

Two signed copies of both the Design Certificate and Check Certificate are to be submitted to the Highway Authority for endorsement. One endorsed copy of both Certificates will then be returned.

#### D.3.4 Maintenance audit of the design

Once the signed copies of the design and check certificates have been submitted, a Maintenance Audit is carried out by the Highway Authority. This is to ensure that aspects affecting the ongoing inspection and maintenance of the structure are to the Highway Authority's approval. If the procedures in this section have not been followed and endorsed by the Highway Authority construction WILL NOT be permitted, nor will the highway be adopted.

#### D.3.5 Technical Approval of Construction

The construction work should not commence until all legal agreements are signed and the Consultant is in receipt of the Design and Check Certificates endorsed by the Highway Authority and the Developer's site supervision arrangements are agreed by the Highway Authority. The Developer must notify the Highway Authority of the programmed start and completion dates, prior to any works commencing on site.

#### D3.6

Supervision of the works and the level of supervision shall be the responsibility of the Developer but must be carried out by a competent consultant as specified in the AIP. In addition the Highway Authority is to be permitted access to the works at any time during construction for supervision checking. This will be undertaken at intervals dependent upon construction and must include important aspects of the construction work. The Highway Authority shall be advised in advance and be regularly updated of key operations and their dates in the construction programme. The full costs of the supervision and associated reporting is to be met by the Developer.

#### D.3.7 As-Built Requirements

Upon completion of the works a Construction Compliance Certificate, certifying that the structure has been built in accordance with the approved drawings and specification is to be prepared by the Supervising Consultant. Two signed copies must be submitted to the Highway Authority for endorsement. Included with this must be the As-Constructed Records comprising the As-Built Drawings (as specified by the Highway Authority), Maintenance Manual and the Health & Safety File (in accordance with the Construction (Design and Management) Regulations 2007). The As-Built Drawings, Maintenance Manual and the Health and Safety File should be submitted in both paper and electronic formats. One copy of the Certificate of Construction Compliance will be returned to the Supervising Consultant upon endorsement.

- D3.8 Approval for adoption WILL NOT be given by the Highway Authority until the Certificate of Construction Compliance and the As-Constructed records have been received and approved by the Highway Authority.
- D.3.9 **Structures over the Highway**  
Any structure above or overhanging the existing or proposed highway i.e. balconies; bridging structures etc., may be permitted, providing all statutory regulations are complied with, and the developer applies for a licence under Section 176/177 of the Highways Act.
- D.3.10 **Easements**  
Suitable access shall be provided for inspection and maintenance of structures and where easements are required for this purpose, these shall be negotiated by the developer and transferred to the Highway Authority on adoption of the structure.

## 4E Street lighting

### E.1 General

Adopted highways, which include new streets, footpaths and cycleways shall be provided with street lighting. Private drives and rear private parking courts will be considered for lighting to adoptable standards at the discretion of the Local Authority, at the expense of the developer, including a commuted sum for future maintenance. Street lighting shall be in accordance with current specifications and standards as specified by the Local Authority. Generally, lighting of developments shall be in accordance with appropriate and relevant sections of BS5489. 'Code of practice for lighting for subsidiary roads and associated pedestrian areas'.

### E.2 Design

Ideally the design of lighting schemes will be undertaken as a collaborative effort between the Local Authority and the applicant's design team. The aim should be to ensure that the lighting scheme is coordinated with other elements of the street space and avoids redundant elements, conflicts and clutter. For the purposes of safety, the design of the lighting scheme should ideally achieve a uniformity rating of 0.4U<sub>o</sub> and should never fall below 0.25U<sub>o</sub>. The colour rendering qualities of lamps should achieve a minimum of at least 60Ra (60%) on the CR Index. Details of the final scheme may be subject to approval by planning condition. Schemes prepared by developers shall be submitted to the Local Authority for technical approval for which a design fee for checking will be incurred for each submission at an hourly rate, and a minimum fee as decided by the Local Authority. A specification and/or list of acceptable equipment is available on request. Developers deviating from this list must have the equipment approved by the Local Authority.

### E.3 Installation

An approved scheme should normally be installed by the Local Authority although it could be installed by the Developer or his Contractor. Installation of street lighting shall be in conjunction with development of the site. Where work is carried out by the developer the Local Authority should be asked to approve the positions of the columns prior to erection. If incorrect, the Local Authority may require street lighting to be rectified, otherwise the scheme may not be considered suitable for future adoption.

In certain instances it will be appropriate and acceptable to attach lighting units to buildings. This will normally require a way-leave agreement between the owner, Electricity Company and the Local Authority. Contractors must refer to any specification or requirements of the Local Authority.

### E.4 Electrical supplies

When the Local Authority is providing and installing equipment on behalf of the developer, the Local Authority will normally make the necessary arrangements for the connection of the electricity supplier on the receipt of an official order. Alternatively the Developer or his Contractor, during the installation of equipment must make all the necessary arrangements with the Electricity Company for the connection of the electricity supply, which will always be to the Local Authority Specification.

**E.5 Remote monitoring equipment**

Remote monitoring equipment will be provided and installed by the Local Authority on behalf of the developer on receipt of an official order. Alternatively, where necessary, the Developer will be responsible for the installation of monitoring equipment to the specification of the Local Authority.

**E.6 Adoption of Lighting Units/Test Certificate**

The authority must be notified in writing when the lighting units are ready for inspection prior to adoption. The notification must be accompanied by an electrical test certificate and inventory/asset management details in accordance with the Local Authority specification, relating to the appropriate unit when the unit has been installed by the developer or his contractor.

**E.7 Maintenance**

Where the Local Authority erect/install equipment, energy costs will normally be accepted by the Local Authority from the date of connection of each approved lamp on prospectively adoptable highways and certain discretionary areas referred to above. The Local Authority will normally accept routine maintenance after the highway has been adopted. Where the Local Authority has installed the lighting equipment routine maintenance will be accepted from the date of installation. In the pre-adoption period the developer will be responsible for the replacement and repair of any damaged equipment together with all energy costs when the developer or his contractor has erected/installed the equipment. The Local Authority will not be responsible for routine maintenance or energy costs of any equipment that has not been approved, also, the highway will not be adopted unless agreed with the Local Authority

## 4F Public utilities

### F.1 Provision

F.1.1 Public utility apparatus on estate roads should be provided in the most economic manner consistent with consumer convenience, ease of maintenance and good appearance. **The developer should consult with the statutory undertakers and co-ordinate the location of mains and services during the initial design process.** This is particularly important on shared space streets with level surfaces. The developers should obtain copies of the National Joint Utilities Group publication:

- NJUG Volume 2: Guidelines On The Positioning Of Underground Utilities Apparatus For New Development Sites (Issue 2).

### F.2 Location of statutory undertakers' services

F.2.1 The statutory undertakers prefer to establish routes for their apparatus within areas adoptable as public highway or in land to be maintained by local authorities. To minimise installation and maintenance costs and to avoid future disruption, apparatus will normally be laid in footways adjacent to carriageways. In Shared Space Streets where there is no separate verge or footpath provided, it will be necessary to lay services within the carriageway. In this situation a 2m strip must be allocated at one side of the carriageway for use by Statutory Undertakers. This should normally be on the 'high' side, away from drainage runs. Apparatus should be ducted where future access may be restricted.

Figure 1 shows a recommended arrangement for Utilities' services in a 2 metre wide footway or service strip.

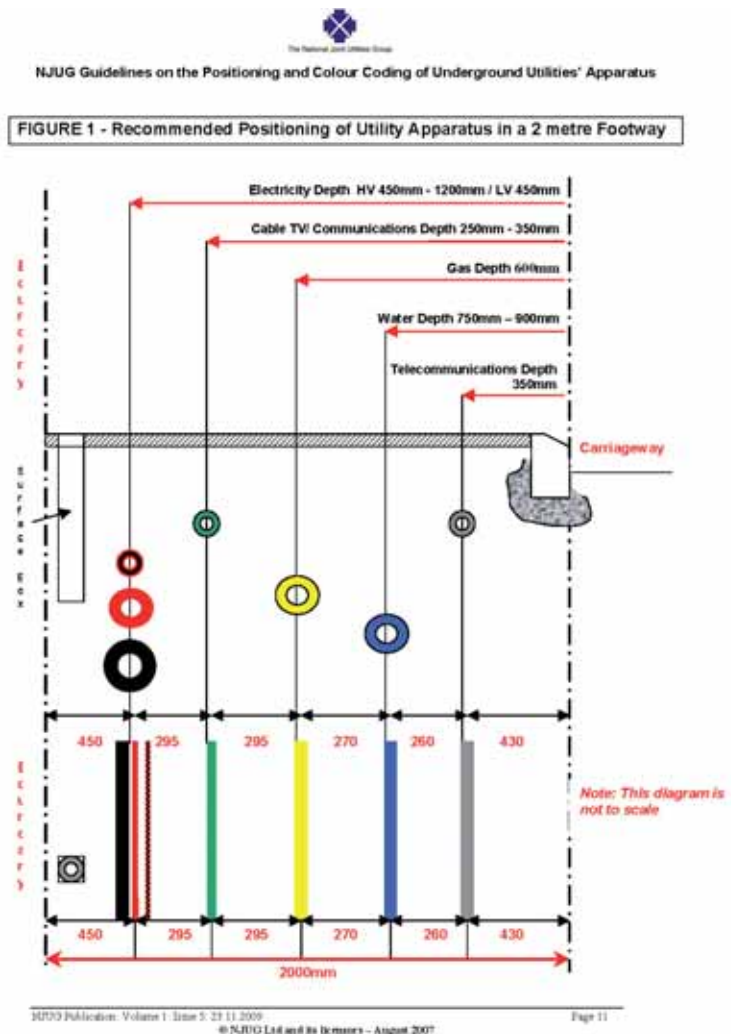

- F.2.2 Electricity and telephone cables must be laid underground for aesthetic reasons.
- F.2.3 Installations such as sub-stations and gas governor houses requiring heavy vehicle access should be located on principal streets outside the limits of the public highway. They should be provided with sufficient parking to accommodate service vehicles clear of the highway and must be fully surfaced in block paving or tarmacadam.
- F.2.4 The siting of water valve boxes, hydrants, post office, mail boxes and telephone boxes requires special attention and must be co-ordinated with the Statutory Undertakers and the emergency services. For aesthetic reasons all surface boxes must be laid parallel to the line of footways/footpaths, verges and paved margins. Recessed covers should be used to provide continuity of tactile paving and block/slab paving.
- F.2.5 Developers should take account that services are usually laid on the side of the road fronting the most properties, and that it will be their responsibility to provide cross-carriageway ducts at agreed locations and to establish means of readily locating the duct ends.
- F.2.6 In the event of the routes available in the adoptable highway being unsuitable, the developer must provide other land as necessary and arrange for satisfactory easements. Neither the Highway Authority nor the Local Authorities have the resources to maintain land that is required solely for public utilities.
- F.2.7 Where services are laid in land outside the control of the Highway Authority or Local Authority, any covenant required should be negotiated between the developer and the undertaker.

### **F.3 Verges and Paved Margins**

- F.3.1 On streets where verges are provided, the Public Utility companies will be discouraged from using them, so as to avoid affecting trees and planting.
- F.3.2 If it is unavoidable that some services need to be placed in verges, then this will need to be taken into account in determining the width of the verge and the need for any root protection systems. Further advice on trees and planting, including species selection and root protection systems, is contained in [Section 4G](#).
- F.3.3 Where paved margins (clearance strips 0.5 metres wide) are provided they must not be used for mains and cables; the exception being for household services and the provision of street lighting.

### **F.4 Cable television apparatus**

- F.4.1 The developer should ascertain if a Cable Television Franchise has been entered into for the area. Should a franchise exist then the developer should ensure that all necessary ducts are accommodated.

### **F.5 Co-ordination**

- F.5.1 The layout design must reconcile the sometimes conflicting requirements of highway authority, public utilities and local authority, always bearing in mind that the main objective of these standards is to create a better environment, particularly on residential estates.
- F.5.2 Trees and shrubs in close proximity to public utilities can cause damage to utilities, and the plants themselves will be damaged by excess excavation. Further advice on trees and planting, including species selection and root protection systems, is contained in [Section 4G](#).

F.5.3 In addition, the layouts of the several services must be co-ordinated, although the joint trench principle is an ideal which is not often practicable. However, care must be taken to ensure the services do not conflict.

F.5.4 Developers must provide the public utilities with their proposals at the earliest possible stage, and the designers must consider services as a basic design element.

### **F.6 Public Sewers and Drains**

F.6.1 The location of public sewers and drains must be agreed with the appropriate Water Authority who will require adoptable sewers to be laid within highway limits normally in the carriageway. In the case of drains catering solely for the discharge of surface water from prospectively adoptable highways, the highway authority should be consulted.

F.6.1 The space requirements for access to sewers and manholes may have implications for carriageway widths and should be taken into account.

### **F.7 Shared Private Drives**

F.7.1 Developers are reminded that these will not be adopted, but dependent upon the position of the properties they serve, the statutory undertakers may require to lay services with their associated access boxes, within them. Proper and adequate protection will be required and they may also acquire a covenant in the conveyance to advise purchasers of their presence and need for access for future maintenance.

## 4G Street trees

### G.1 INTRODUCTION

#### G.1.1 The case for highway trees

G.1.1.1 South Yorkshire is well known for its urban landscapes which have benefitted from tree planting across many areas. However a recent audit of the urban forest within parts of Sheffield has shown that a significant percentage of the large mature trees are nearing the end of their natural life. The high use of Prunus and Sorbus tree species over the past 50 years has done little to mitigate this situation. It is with the threat of a possible decline in tree numbers that this Guide has been produced to enable designers and developers to plant appropriate trees in and adjacent the highway.

G.1.1.2 It is quite easy to demonstrate that trees have a powerful impact on people's perceptions of the visual quality of streets and urban spaces. Not only do people feel better in a tree-lined environment (whether or not the individual recognises this) but they are prepared to pay to live in one.

G.1.1.3 Conversely, damage to paving, problems caused by fallen leaves and branches, damage to services and adjacent buildings and safety issues have all been cited at one time or another as a reason not to plant trees. However, with correct detailing of the planting area, careful species selection and good management most of the problems can be overcome.

G.1.1.4 Trees are important in the South Yorkshire street scene improving amenity and biodiversity; it is now imperative to take action to reinvigorate the legacy of tree planting that makes South Yorkshire green and attractive.

G.1.1.5 Large, mature trees are the most valuable and the developer should consider the largest, longest lived species suitable for the given space and their landscape impact. Neither can the survival of newly planted trees be left to chance. Trees are generally highly adaptable to hostile environments and with the correct specifications, choice of species and variety and attention to detail at all stages of the project, there is no reason why survival and subsequent growth should not be comparable to a non-urban situation.

### G.2 GENERAL GUIDANCE

G.2.0.1 The following section gives general guidance proposing methods for successful tree planting in situations that are commonly encountered in highway areas and provides background information to the specifications.

G.2.0.2 Where specific guidelines are given then reference should be made to the relevant specification and drawn detail as indicated. The developer is encouraged to seek advice from qualified arboriculturists and discuss tree planting proposals as early as possible with Local Authority officers including arboriculturists, landscape architects, lighting engineers, highways engineers and development management to agree the most suitable solution.

#### G.2.1 The planting hole

##### G.2.1.1 Existing Ground

Excavate one planting pit to act as a trial pit that will enable the following to be established:

- Quality of topsoil
- Possible drainage problems
- The presence of underground services.

**G.2.1.2 Quality of topsoil** – (as defined in BS 3882:2007)

It is possible to assess the quality of soil by using a simple 'finger and thumb' test as outlined in the BS but essentially a light, sandy and 'open' texture is required. Where the excavated topsoil from the planting pit, and the surrounding soil, is of a suitable quality then it is of little benefit to add any other medium during the planting operation with the exception of a slow release fertiliser (such as Bonemeal or Scotts 'Enmag' ), applied at the time of planting and at manufacturer's recommended rates.

**G.2.1.3** If the soil has a poor texture then it is possible to improve this with conditioners such as peat-free compost made from recycled organic materials incorporated in the planting pit not exceeding 5% of backfill volume (if a greater content is required then this should be added to the surface as a dressing - research for amenity trees No 8 - 2006). It is not possible to make long term improvements to, say, pH or nutrient content, to such an extent as to benefit the tree for more than its initial establishment period. It is also important to recognise that digging a pit in clay soils and backfilling with a lighter, free draining planting medium, is likely to result in the creation of a sump into which water from the surrounding ground will flow. In these circumstances, a drainage layer at the base of the planting pit should be provided or connection to an established drainage system via pipe work.

**G.2.1.4 New ground**

In new ground, or in areas of major excavation, it is possible to create conditions that will give new trees the best possible start and minimise future disruption to the surrounding area. This will include:

- Adequate soil volumes
- Good quality topsoil
- Protection to surrounding paving and adjacent services
- Drainage provision if necessary in urban areas, where little or no existing soil is within reach of growing roots. The size of the planting pit and the quality of soil are the two most important factors that will have a bearing on the future growth of the trees.

**G.2.1.5 Pit size - soil volumes.**

The volume of soil required to support a mature tree depends on type and ultimate size of the tree, water availability and ground water storage, particularly during drier seasons. While formulae are available to calculate the volume of soil required, 20 cubic metres appears to be required to maintain reasonable growth in a paved situation. When planting into existing areas this volume may be difficult to achieve but it must be recognised that trees planted in a lower volume of soil may not reach their ultimate mature size and maintain good leaf growth/ shoot extension, unless their roots can extend beyond the pit into adjacent soil areas, e.g. grass verges, gardens, etc.

**G.2.1.6** Where possible a minimum soil volume of 5 cubic metres should be provided.

The shape of the soil area need not be regular and can be altered to suit site conditions including constraints due to remediation. Volume cannot be achieved by providing extra depth. The maximum useful depth of topsoil for tree planting is 900mm. It is acceptable for more than one tree to utilise the same soil. For example, a tree pit 900mm deep x 3 metre wide x 8 metre long containing 21 cubic metres of soil could support two trees planted at 6 metre centres. A similar pit 16 metres long containing 43 cubic metres would support three trees, and so on.

## G.2.2 Soil

- G.2.2.1 Imported topsoil shall be of good quality, with a light texture, and conform to BS 3882 *General Purpose Category*. Unless the topsoil is from a reliable source that previously supported good plant growth the following tests are required:
- pH - the soil pH should be between 5.5 – 7.8 - organic matter - which should be greater than 5%
  - Nitrogen (N) - which should be greater than 0.2%
  - Phosphorous - which should be greater than 45 mg/kg
  - Potassium - which should be greater than 240 mg/kg
  - Magnesium - which should be greater than 80 mg/kg More involved tests for phytotoxic elements (e.g. copper, nickel, zinc) and zootoxic elements (e.g. arsenic, lead, mercury) need only be undertaken if there is any doubt regarding the origin of the topsoil. The tests must be undertaken by a recognised testing laboratory and presented to the client prior to importing topsoil to the site.
- G.2.2.2 The planting pit shall be backfilled only when the weather is dry and the soil in a relatively dry condition. The pits should be backfilled in layers not exceeding 300mm and lightly 'settled' rather than compacted between each layer. As long as the soil is not wet or heavy this is best achieved by light treading.
- G.2.2.3 There are two alternatives for a planting medium - on the one hand topsoil or, on the other, where significant vehicle loads on a surface paving material are expected, a supported soil such as (Greenleaf) Rootcell Soil Structure Systems which can be filled with topsoil or a 'manufactured' soil, such as 'Amsterdam' or 'load bearing tree soil' to ensure that optimum conditions for root growth are maintained, to the approval of the Local Authority.
- G.2.2.4 If the organic content is low or the structure of the soil can be demonstrated to be poor then a peat-free planting compost should be added at the supplier's recommended rates. Alternatively, compost from a reliable source can be added at a rate not exceeding 5%, by volume, ameliorant to topsoil (if a greater content is required then this should be added to the surface as a dressing). In all cases the mixing must be carried out before adding the soil to the excavated tree pit in order to obtain a homogenous mix. It is important to realize that the gradual decomposition of organic material in the soil, resulting in a series of small but linked voids, is one cause of settlement in surface paving adjacent to tree pits. For this reason, 'load bearing' tree soils are exceptionally low in organic matter, not exceeding 5% by volume with the subsequent need for regular soil management.

## G.2.3 Root barriers

- G.2.3.1 Where there is concern that adjacent services, such as gas and water pipes and electricity cables, might be affected by growing root systems then an impenetrable barrier should be installed which will prevent damage by future root growth.
- G.2.3.2 Where there is danger of damage to services on just one side, or any other reason why roots should be prevented from growing in one direction such as building foundations, a strip barrier is preferable such as Greenleaf 'Reroot 1000'. The barrier must be installed from surface level to a minimum of 1.0 metre below surface level with joints overlapped by 300mm. In a new build situation, within 8m of building foundations or adjacent to service runs that are deeper than 1m the barrier must extend to a depth of 2 metres – Greenleaf 'Reroot 2000' or equivalent approved.

G.2.3.3 Where excavation is limited to the area of the planting pit a pre-formed barrier (e.g. Greenleaf 'Root Directors') shall be installed to the manufacturer's instructions. The barrier must be manufactured in such a way as to discourage the tree roots to spiral around the inside but encourage them to grow in a downward direction. In paving, the backfill surrounding the 'root director' must be compacted sufficiently to support the paved surface material and discourage roots that emerge from the base of the 'director' from reaching back up to the surface layers.

#### **G.2.4 Drainage**

G.2.4.1 It is a prime requirement of any tree planting situation that planting pits do not hold water and become waterlogged. In new construction the minimum requirement is a layer of stone consisting of 200mm deep of clean aggregate 50mm nominal size in the base of the pit topped with a geotextile blanket, to reduce contamination of the drainage layer by fines. This will allow surplus water to drain freely from the rooting zone.

G.2.4.2 Particular care must be taken when excavating tree pits in clay soils where there is a danger of creating a sump and the subsequent water logging of tree roots. It may be necessary in these situations to provide active drainage to remove excess water away from the tree rooting zone.

G.2.4.3 The minimum layer of aggregate may also need to take into account constraints due to remediation.

#### **G.2.5 Tree support - staking and guying**

G.2.5.1 The purpose of staking and guying is to anchor the tree and stabilise the root ball until new roots are established into the surrounding soil, it should not be seen as a method of protecting from vandalism or physical damage. For this reason, support is required until the roots, damaged during the lifting process, have made sufficient new growth. In reasonable growing conditions this should be achieved within three seasons after planting.

G.2.5.2 Above ground supports shall be restricted to private areas and open spaces where vandalism to the supports is unlikely.

G.2.5.3 Below ground support may be used in paved areas to remove the need for above ground guying. It is achieved using specialist proprietary ground anchor systems, such as Platipus or Greenleaf products. Alternative methods of anchoring the trees such as timber or concrete dead man system in the base of the pits may also be considered. Below ground support must be placed at the time of pit excavation and fitted with all necessary wire cables prior to back filling the pit and planting the tree. Tensioning of the wire is by turnbuckle or ratchet systems. Refer to BS 4043 for illustrations and detailed requirements.

G.2.5.4 Tree protection guards may be used in areas of potential vandalism or where their use would be appropriate. Grills however, are not designed to provide support and this must be achieved using appropriate underground or above ground systems. Check with the relevant local authority about their specific policies on the use of tree guards.

G.2.5.5 The developer should agree the best method of tree anchoring with planning to ensure that the best method is used in the context of the setting.

## G.2.6 Tree selection

The following issues must be considered when making a choice of trees for planting adjacent to the public highway.

### G.2.6.1 Ultimate Mature height

- Small – to approximately 10 metres
- Medium – to approximately 15 metres
- Large – greater than 15 metres

### G.2.6.2 Ultimate shape and spread

- In general, when planting adjacent to highways, particularly where high sided vehicles regularly pass, it is preferable to select a variety with relatively upright growth that will not require pruning or be damaged by the passage of vehicles. Alternatively, select species whose crown will be, or can be, formed above headroom constraints. Away from the immediate kerb line a broader crown could be considered. For the purposes of safety, in areas to be used by pedestrians and other non-vehicular street users, select species that would allow crown lifting to a minimum of 2 metres above the pavement with a clear stem.

### G.2.6.3 Site conditions

- As long as the soil is free draining and near-neutral pH then most commonly specified street trees will grow well. Exposure, particularly to strong and cold winds, may be a problem for some trees i.e. those with large leaves, a weak branch structure or brittle wood.

### G.2.6.4 Species specific or varietal features

- E.g. a tree that has good spring flowers, autumn berries or autumn colour may be positive aesthetically, but consideration should be given to such fruit and blossom falling on pavements which may be considered a hazard. Therefore, the suitability of these features in each given situation should be carefully thought through.

A list of suitable trees for planting next to the highway in South Yorkshire, is included in [sub-section 4G.4, below](#).

### G.2.6.5 Size of Planting

For street tree planting trees will be selected from one of the following girth sizes:

<b>Heavy Standard</b>	12-14cm	Likely to require protection in a public situation but will provide a greater initial impact.
<b>Extra Heavy Standard</b>	14-16cm	More resistant to casual damage and generally the preferred minimum size in a public location.
<b>Semi Mature</b>	16-35cm	Trees of this size will provide good resistance to casual damage and provide excellent initial impact. However they require specialist handling and greater attention during the establishment period.
<b>Mature</b>	35cm +	The above comments apply. Trees planted in these sizes and above would be considered suitable for planting in the city centre or in a development where a strong focal element is required. Advice should be sought from the city council landscape architect.

- G.2.6.6 It is generally accepted that the smaller the tree is at planting the quicker it will establish and start into new growth.
- G.2.6.7 Improvements in modern nursery practice and recognition of the importance of site evaluation or assessment to identify species compatible with the physical properties offered by the site has changed this situation. So it is always important to consider the source of the stock, its size and the species used to mitigate any potential problems that could occur.
- G.2.6.8 In most urban situations a minimum girth of 14cm will suffice for newly planted trees. However if there is a high risk of vandalism or other damage then 18cm girth trees must be planted. But it should be remembered that larger root stock of this size is more likely to fail and trees of this girth should be either containerised stock or root-balled. (Refer to BS 4043:1989. Recommendations for transplanting root-balled trees).
- G.2.6.6 **Root type – Which to use: bareroot, rootballed or containerised?**  
Bare-root stock is usually the cheapest available and when the correct practises are followed they will establish at a faster rate. This is the preferred option for trees below 18cm in girth. It is highly recommended that a root dip mycorrhizal inoculant treatment is used when planting smaller bare rooted trees to ensure that the trees are best prepared to survive the first planting season.
- G.2.6.10 Trees above 18cm girth should be either containerised stock or root-balled. The advantage of root-balled and containerised is that they can be planted any time of year as long as a proper irrigation plan is in place. Choice of stock type will also depend on the species.

### G.2.7 Aftercare and maintenance

- G.2.7.1 Maintenance of newly planted trees for at least 3 years after planting is essential to their long term survival and growth. Larger trees, in particular those above 25cm girth, can take several years to finally die, living off stored resources rather than newly acquired ones. A guarantee period of at least 3 years (5 years for trees of 35cm girth and above), must be imposed on all new tree planting.
- G.2.7.2 Incorrect handling at any stage of the works, failure to prepare the planting pit correctly, poor planting techniques and lack of moisture at first bud-burst can lead to poor establishment during the first 12 months of the tree in its new position. A tree may be in leaf at the end of its first growing season but unless it has made sufficient growth to sustain it well into the next season, it is likely to be on a downward spiral from which there is no return. A tree showing lack of vigour at the end of its first season should be treated the same as a dead tree and scheduled for replacement.
- G.2.7.3 Operations to be carried out during the maintenance period must include:
- **Watering** – A minimum of 90 litres per tree shall be applied at fortnightly intervals between the period 1st May to 30th September. If April is dry, newly planted trees should be watered during this month at the same frequency. If particularly wet weather occurs, supplementary watering may not be necessary. The use of larger quantities of water at greater time intervals is not an adequate alternative and is not acceptable.
  - **Pruning** – at the time of planting any damaged branches must be cut back to a main junction or stem. Also beneficial to the tree is the reduction of crown growth by removing weaker side branches. At the end of the first growing season, any branches showing signs of dieback must be cut back to live wood. Pruning must take place during the dormant period except for Prunus species when mid-summer pruning is recommended to reduce the likelihood of disease. Pruning cuts shall not be painted with any type of wound sealing paint.

- **Support** – check trees for stability and if necessary re-tie or expose underground supports to tighten the wires.
- **Tree pits** – keep clear of weeds. Where trees are planted in grass, a bare circle of soil at least 1m in diameter should be maintained around the trunk. This reduces competition from grass and the likelihood of damage from mowing machines.

G.2.7.4 Long term management and maintenance of the trees should not be neglected after the defects liability period has expired. Growth should be monitored for damage by storm, vehicles or vandalism on a regular basis and any necessary remedial action taken. Timber stakes must be removed three years after planting and when the tree is showing signs of strong growth. Maintenance of an area of bare soil around the base of a tree helps reduce damage by mowers and other grass maintenance equipment.

### G.3 SPECIFICATIONS

#### G.3.1 Specification – Trees in paving areas, underground support BS 4043 & BS 4428 apply

##### G.3.1.1 Pit size and construction

Pits shall be 600mm wider than the diameter of the root ball with a minimum size of 900 x 900mm. Minimum depth to be 750mm subject to any limits imposed by site constraints. Where necessary the depth shall be increased to accommodate the depth of the root ball and to obtain the correct planting level. Break up bottom of pit to 150mm deep and scarify the sides of the pit with a fork.

##### G.3.1.2 Planting

Remove any moisture-retentive material used to prevent the root ball drying out during transport from the nursery but protect the root ball from sun and wind during the planting operation. Move the wire mesh support and root packing away from the trunk of the tree but do not cut away from the main root ball, the integrity of the wire mesh must not be damaged. Do not cut the wire mesh. Plant trees upright and, unless otherwise instructed, in the centre of the pit.

##### G.3.1.3 Planting depth

The natural thickening between the trunk and the root collar shall be at the finished top surface of the planting medium. A straight edge placed across the pit at finished surface level and adjacent to the tree will assist in gauging the correct level. If necessary, the depth of the pit must be adjusted to ensure the correct planting level.

##### G.3.1.4 Drainage

Below-ground irrigation and aeration systems such as Greenleaf 'Root Rain Urban' should be installed where required in hard surfaced areas and for any trees in hard or soft areas above heavy standards or with girth above 25cm. Ensure that the top of the filler pipe is flush with finished surface levels. Backfill around the root ball with specified material in 150mm layers, treading lightly to compact each layer to a level approximately halfway up the side of the root ball. The underground support should be installed prior to completing the backfilling of the pit. Immediately after planting the tree shall be watered with approximately 25 litres of water to ensure that the contact of soil between the root ball and backfill material is uniformly moist.

##### G.3.1.5 Underground support

Underground ground anchorage system such as: 'Root-ball Guying Kit', as supplied by Platipus Anchors Limited, Greenleaf urban tree and landscape products or equivalent approved, or alternatively, Deadman System comprising 2 No. dead man anchors of timber or concrete located at opposite sides of the root ball, rectangular in section and of sufficient mass to prevent movement when buried below the soil. The dead man anchors and root ball fixing wires must be

fixed prior to backfilling the pit or placing the tree. Multi-strand wire 5mm diameter shall be stapled around each anchor and shall be tensioned by turnbuckle or ratchet devices or 'gripple' system after the tree is in its final position.

#### G3.1.6 Grilles

Check with the relevant local authority about their specific policies on the use of tree grilles. If used, tree grilles should have removable inner rings and should be detailed to reduce drainage into tree pits by water contaminated by de-icing salts.

### G.3.2 Specification - Trees in paving - root director / root barrier

BS 4043 & BS 4428 apply

#### G.3.2.1 Pit size and construction:

Pit size and construction: the minimum size of the tree pit will be 1200 x 1200 x 1100mm deep. Excavate a planting hole 600mm wider than the diameter of the root ball. The depth of the excavated pit will be sufficient to accommodate the root ball and to obtain the correct planting depth. Install a layer of clean stone or granular material such as reclaimed broken bricks to a settled depth of 200mm. Cover with a geotextile sheet to filter fine particles. Granular material (if used) should be free of fines.

#### G.3.2.2 Installation of root director / root barrier

Supply and install a root director (product code RD1050) as supplied by Greenleaf, Haywood Way, Hastings, East Sussex. TN35 4PL or equivalent approved. Installation shall be in accordance with the supplier's instructions.

### G.4 RECOMMENDED TREE SPECIES FOR PLANTING HIGHWAY LOCATIONS

G.4.1.1 The following list of tree species are considered suitable for planting in South Yorkshire. Trees may be selected from the following list taking note of species considered not suitable. Inclusion in the list does not mean that all species are suitable in all situations. Selections must be based on a match between the habit and requirements of the species and the conditions of the specific location.

G.4.1.2 Alternative species or new varieties may be acceptable. The developer should discuss the suitability of the species for the scheme with the authority an early stage in design, whether selected from the list or offered as an alternative.

This list is not designed to be an exhaustive selection of trees. If a species not shown on this list is to be considered it should be referred to the relevant authority for approval.

Tree name	Prime choice	Size	Spread m	Height m	Growth rate	Root depth	Wind firm?	Leaf colour	Flower colour	Form	Notes
Acer campestre Elsrijk		S-M	6	15-20	Slow		L/GR > YL	n/a	Broad conical	Regular habit, Good yellow autumn colour, Tolerates drought	
Acer campestre 'Streetwise'		S-M	6	15-20	Slow					Upright form of Field Maple, good autumn colour	
Acer campestre Louisa Red Shine		S-M	6	15-20	Slow		MV/GR		Rounded	Tolerates drought	
Acer cappadocicum		M	12	15-20	Medium		GR/GR	YL/GR	Broad	Needs space, ok for large corner verges. Not suitable for exposed sites. Avoid root compaction. Spring and autumn foliage colour.	
Acer platanoides Columnare		M	4-5	15-20	Slow		LI GR > YL > OR		Columnar	Good street tree. Virtually no maintenance. Good autumn colour.	
Acer platanoides Emerald Queen		L	16	20+	Fast		mid GR		Rounded	Good general purpose tree, needs space, good in large verges.	
Alnus cordata		M	7	15-20	Fast	Shallow (see note)	GR (see note)	YL catkin oval	Broad	Tolerates dry soils. Will cause damage to paved areas so restrict use to grass verges and reservations. Leaves retained well into winter.	
Amelanchier arborea Robin Hill	✓	S-M	6	10-15	Medium		GR > OR/VD	WH	Oval	Lime free soils. Low maintenance. Good autumn colour, orange and red	
Carpinus betulus L		L	12	20+	Slow		GR > YL		Round	Shade tolerant. Good in poor planting conditions. Yellow leaves in autumn	
Carpinus betulus Fastigata Frans Fontaine	✓	M	4	15-20	Slow				Pyramidal		
Corylus colurna L		L	8	15-20	Fast				Pyramidal	Yellow catkins in spring. Rough textured, corky bark. Yellow autumn colour	
Crataegus laevigata Paul's scarlet		S	6	10	Slow		see note	RD		Difficult to establish? Requires regular pruning in early years to allow roots to develop and become wind firm.	
Crataegus monogyna Stricta	✓	S	2	<10	Slow			WH	Columnar	Good street tree, ideal for restricted space.	
Fagus sylvatica		L	16	20+	Slow	Shallow rooting	see note		Rounded	Needs space. Under planting difficult due to heavy shade. Copper autumn foliage. Can drop branches without warning!	
Fagus sylvatica Dawyck		M-L	4	15-20	Slow	Shallow rooting			Columnar	Very narrow upright form of beech, good for street planting.	
Fagus sylvatica Riversii		L	14	15-20	Slow	Shallow rooting	PL > BR		Rounded	Needs space. Under planting difficult due to heavy shade. Copper autumn foliage. Do not over plant?	
Fraxinus angustifolia Raywood		S-M	7	10-15	Fast		GR > RD			Susceptible to producing weak branch unions that lead to crown failure. Purple/Wine red autumn colour. Bears soil compaction well.	
Fraxinus excelsior Allena	✓	M	7	15-20	Fast			WH	Pyramidal	Ascending branches, good for road side planting	
Fraxinus excelsior Westhof's Glorie	✓	L	7	20+	Fast		> YL	WH	Oval	Narrow when young spreading to oval.	

Tree name	Prime choice	Size	Spread m	Height m	Growth rate	Root depth	Wind firm?	Leaf colour	Flower colour	Form	Notes
Ginkgo biloba		L	?	20+	Fast	Deep rooting	Good	> YL		Conical	Narrow when young, broadening with age. Good autumn colour.
Gleditsia triacanthos Skyline			?	15 - 20	?		see note	LgGR	WH	Pyramidal	Can be susceptible to wind damage. Tolerates pollution.
Gleditsia triacanthos Sunburst		M	6	15 - 20	?		see note	YL	WH	Tall, upright	Can be susceptible to wind damage. Tolerates pollution. Can be difficult to establish?
Liquidambar styraciflua Worpleston		L	8	20+	Slow		see note	> ORRD		Pyramidal	Needs shelter from wind. Withstands dry soils and pollution. Excellent autumn colour orange to wine red.
Malus hupehensis		S	3	10	?				WH	Upright, columnar	Fragrant flowers in May-June. Fruits dark red.
Malus trilobata		S-M	3	10 - 15	?			> RD	WH	Upright, columnar	Good upright street tree. Maple shaped leaves. Large flowers, occasional fruit.
Malus tschonoskii	✓	S-M	4	10 - 15	Fast			GY/GR	WH	Pyramidal	White flowers late spring, Good orange red autumn colouring
Metasequoia glyptostroboides	✓	L	?	20+	Fast			GR > PK/RD			Tolerant of air pollution
Platanus x hispanica		L	6	20+	Fast						Very tolerant of urban pollution. Not good in cold exposed sites
Platanus orientalis digitata		S-M	6?	10 - 15	Fast			> YL			Good yellow autumn colour.
Prunus avium Plena		M	8	10 - 15		Shallow (see note)	Good	> RD/OR	WH (Double)	Pyramidal	Smooth bark dark red. May suffer mechanical root damage?
Prunus 'Ichijo'		S	8	8	Slow?	?		BronzeGR	PK	Upright	Good street tree. Upright, large pink flowers in Spring.
Prunus padus 'Albertii'	✓	S-M	6	10 - 15	?	?	Good		WH	Oval	Strong upright growth. Free flowering
Prunus 'Pandora'		S	7	10	?	?	Good	BronzeRD > YL	PK	Columnar	Free flowering. Excellent Spring and Autumn colour
Prunus sargentii 'Rancho'		S	9	10	Fast	?		> YL/OR	PK	Rounded	Upright form of P.'Pandora'
Prunus x schmittii	✓	S-M	8	10 - 15	Fast	?				Conical	Upright, polished brown bark. Good Autumn colour. Requires virtually no pruning.
Prunus x subhirtella Autumnalis	✓	S	8	10	Fast	?		> YL	WH	Broad/ open head	Autumn - Spring flowering. Good Autumn colour
Prunus 'Sunset Boulevard'		S	narrow	5 - 10	Fast	?		Copper > YL	WH	Columnar	
Prunus Tai Haku	✓	S-M		10 - 15	?	?		Copper	WH	Rounded	Very white, good for cut de sacs?

Tree name	Prime choice	Size	Spread m	Height m	Growth rate	Root depth	Wind firm?	Leaf colour	Flower colour	Form	Notes
<i>Pyrus calleryana</i> Chanticleer	✓	S-M	6	10 - 15	?			> OR/RD	WH	Columnar	Fine street tree, tolerant of pollution
<i>Pyrus calleryana</i> Redspire	✓	S-M	6	10 - 15	?			> OR/RD	WH	Columnar	Similar to P.C Chanticleer, but better autumn colour
<i>Quercus palustris</i>		M - L	6 - 7	10 - 15	Medium			> RD		Pyramidal	Good for avenues where space allows. Good scarlet autumn colour.
<i>Quercus robur</i>		L	8	20+	Medium	Expansive rooting	Good	Lt GR > YL		Oval	Needs time to establish. Very long lived, needs space to develop. Can be variable in form and growth?
<i>Quercus robur</i> 'fastigiata'		S-M	3	10 - 15	Medium	Expansive rooting	Good	Lt GR > YL		Columnar	Needs time to establish. Very long lived, needs space to develop. Good avenue tree.
<i>Sorbus aria</i> Majestica		M	8	10 - 15	Fast		Good (see note)	GY/GR	WH	Rounded	Large leaves very silver in spring. Bright red berries in autumn. Wind firm once established, requires early support in windy locations?
<i>Sorbus x arnoldiana</i> Schouten	✓	S	3 - 4	10	Fast			GR		Oval	A reliable low maintenance tree. Golden yellow fruits.
<i>Sorbus aucuparia</i>		S-M	5	10 - 15	Variable			Dk GR > OR/RD/YL		Variable	Best grown as multi stem form. S,a forms do not like reflected heat and light associated with paved areas. Red fruits in autumn
<i>Sorbus aucuparia</i> Cardinal Royal	✓	S-M	5	10 - 15	Fast			Dk GR > OR/RD/YL	WH	Columnar	Good in restricted areas. Red fruits in autumn.
<i>Sorbus aucuparia</i> Sheenwater seedling	✓	S-M	5	10 - 15	Fast			GR/GR > OR/RD/YL		Narrow oval	Good street tree. Orange red fruits in autumn
<i>Sorbus commixta</i> Embley		S	10	3 - 4	Fast			> RD		Columnar	Compact form, excellent autumn colour, yellow berried.
<i>Sorbus intermedia</i> Brouwers	✓	S-M	8	10 - 15	Fast		Good	see note > YL	WH	Upright oval	Good street tree. Dark green leaves, silver grey undersides. Orange red fruits. Good in windy locations.
<i>Sorbus x thuringiaca</i> Fastigiata		S	3 - 4	10			No (see note)			Columnar	Good street tree. Not ideal in windy sites? Good red autumn fruit.
<i>Tilia cordata</i>		L	8	20+	Variable			Dk GR/GY underside		Rounded	
<i>Tilia cordata</i> Greenspire	✓	S-M	5 - 6	10 - 15	Fast			Dk GR/GY underside		Narrow, pyramidal	Better choice than T. cordata. More free of aphids than other limes.
<i>Tilia x euchlora</i>		L	6	15 - 20	Fast			Dk GR/GY underside	YL/WH	Pyramidal	Better choice than T. cordata as no 'dripping'. Good for pollarding.
<i>Tilia Mongolica</i>		S	6 - 8	10	Fast					Rounded	
<i>Tilia tomentosa</i> Brabant		L	8	20+	Fast		Good			Pyramidal	Considered to be aphid free? Leaves toxic to bees. Good for urban environments. Effective in windy locations as it shimmers. Uniform shape.
<i>Ulmus Dodoens</i>		L	8	20+	Fast		Good	Lt GR/GY underside > YL		Pyramidal	Needs space. Good choice in windy exposed locations.

Tree name	Prime choice	Size	Spread m	Height m	Growth rate	Root depth	Wind firm?	Leaf colour	Flower colour	Form	Notes
Ginkgo biloba		L	?	20+	Fast	Deep rooting	Good	> YL		Conical	Narrow when young, broadening with age. Good autumn colour.
Gleditsia triacanthos Skyline			?	15 - 20	?		see note	LgGR	WH	Pyramidal	Can be susceptible to wind damage. Tolerates pollution.
Gleditsia triacanthos Sunburst		M	6	15 - 20	?		see note	YL	WH	Tall, upright	Can be susceptible to wind damage. Tolerates pollution. Can be difficult to establish?
Liquidambar styraciflua Worpleston		L	8	20+	Slow		see note	> OR/RD		Pyramidal	Needs shelter from wind. Withstands dry soils and pollution. Excellent autumn colour orange to wine red.
Malus hupehensis		S	3	10	?				WH	Upright, columnar	Fragrant flowers in May-June. Fruits dark red.
Malus trilobata		S-M	3	10 - 15	?			> RD	WH	Upright, columnar	Good upright street tree. Maple shaped leaves. Large flowers, occasional fruit.
Malus tschonoskii	✓	S-M	4	10 - 15	Fast			GY/GR	WH	Pyramidal	White flowers late spring. Good orange red autumn colouring
Metasequoia glyptostroboides	✓	L	?	20+	Fast			GR > PK/RD			Tolerant of air pollution
Plantanus x hispanica		L	6	20+	Fast						Very tolerant of urban pollution. Not good in cold exposed sites
Platanus orientalis digitala		S-M	6?	10 - 15	Fast			> YL			Good yellow autumn colour.
Prunus avium Plena		M	8	10 - 15		Shallow (see note)	Good	> RD/OR	WH (Double)	Pyramidal	Smooth bark dark red. May suffer mechanical root damage?
Prunus 'ichiyo'		S	8	8	Slow?	?		BronzeGR	PK	Upright	Good street tree. Upright, large pink flowers in Spring.
Prunus padus 'Albertii'	✓	S-M	6	10 - 15	?	?	Good		WH	Oval	Strong upright growth. Free flowering
Prunus 'Pandora'		S	7	10	?	?	Good	BronzeRD > YL	PK	Columnar	Free flowering. Excellent Spring and Autumn colour
Prunus sargentii 'Rancho'		S	9	10	Fast	?		> YL/OR	PK	Rounded	Upright form of P.'Pandora'
Prunus x schmittii	✓	S-M	8	10 - 15	Fast	?				Conical	Upright, polished brown bark. Good Autumn colour. Requires virtually no pruning.
Prunus x subhirtella Autumnalis	✓	S	8	10	Fast	?		> YL	WH	Broad/ open head	Autumn - Spring flowering. Good Autumn colour
Prunus 'Sunset Boulevard'		S	narrow	5 - 10	Fast	?		Copper > YL	WH	Columnar	
Prunus Tai Haku	✓	S-M		10 - 15	?	?		Copper	WH	Rounded	Very white, good for cut de sacs?

## FURTHER INFORMATION

Table 1. Direct and indirect problems and possible solutions for establishing trees in public locations to be considered by the developer.

Problem	Possible solutions
<b>Direct</b>	
<b>1. Irrigation</b>	Planting maintenance techniques Develop irrigation plan Balance planting quantity with resources
<b>2. Soil compaction or poor quality</b>	Species selection Site selection and assessment Trench planting
<b>3. Direct damage</b>	Planting style (physical barriers) Location selection Site assessment Care during transport and storage
<b>4. Poor planting</b>	Reduce extent of planting Monitor planting techniques
<b>5. Poor tree quality</b>	Develop quality purchase system Build relationships with suppliers Mix suppliers periodically
<b>6. Maintenance (lack of)</b>	Plant in accordance with available resources Maintain accurate records
<b>7. Planting logistics</b>	Plan planting exercise
Problem	Possible solutions
<b>Indirect</b>	
<b>1. Physical damage (from other service delivery, e.g., grass cutting)</b>	Notification of planting sites Interdepartmental consultation Pre-planning
<b>2. Limited finance / resources</b>	Planting style/quantity Establish priority requirements Explore sources of finance Contract management Adopt a tree-planting strategy
<b>3. Development / refurbishment</b>	Interdepartmental consultation/agreements Planting awareness, advertising Accept scheme has a limited "shelf life"
<b>4. Neglect</b>	Establish sense of ownership Satisfy requests for trees Plant for personal reasons, e.g., commemorative Promote maintenance by residents
<b>5. Vandalism, people pressure</b>	Public consultation Establish the level of tree desirability

**Reference documents:**

Hal St G. Appleyard (2000) 'A Strategy to establish trees among high density housing' *Journal of Arboriculture* 26(2)

Biddle, P.G. (1998) *Tree root damage to buildings: causes, diagnosis and remedy*, Willowmead Publishing, Wantage.

Neely and Watson (1994) *The Landscape Below Ground*

Newcastle City Council (2006) *Highway Tree Design Guide*. NCC

Roberts, Jackson and Smith (2006) *Tree Roots in the Built Environment Research for Amenity Trees No.8*

Watson and Himelick (1997) *Principles and Practice of Planting Trees and Shrubs*

## 4H Materials

### H.1 INTRODUCTION

#### H.1.1 Background

- H.1.1.1 This section sets out the materials that are likely to be adopted by the Local Authorities in South Yorkshire for their residential streets.
- H.1.1.2 Attention to detail in both design and construction are important in determining the final look and feel of an area or development. Such detail can give places character and local identity. The public realm can have a significant effect on the safety of a place as well as affecting the ease and efficiency of management and maintenance.
- H.1.1.3 The choice of materials can be used to create a more attractive street scene while still retaining durability and functionality. This extends to street lighting (see [Section 4E](#)), street furniture and signs (see [Section 4I](#)) which influence the overall perception of the area. The materials set out here may not be appropriate for some situations such as conservation areas. Early discussions with both the Conservation Officer and Highway Authority are recommended.

#### H.1.2 Adopted Materials

- H.1.2.1 The use of an unlimited palette for street materials can produce a confused and untidy appearance and make future maintenance and repair more difficult and costly. The aim of this section is to define a more limited palette of materials that will allow both design and maintenance issues to be resolved. Further detail on the construction specifications for the various materials can be found in the separate document materials specifications available from the Local Authority.
- Adoption of other Materials**
- H.1.2.2 There will be occasions in some specific circumstances, for example in conservation areas, when the more limited palette of adopted materials does not meet the design aspirations or requirements for the area or development. In these cases the proposed materials will need to be submitted to the Local Authority for approval. Any such materials, proposed for adoption should be readily available, sustainable in the long term, preferably locally sourced, economically viable, environmentally friendly and meet the necessary properties/specification.
- H.1.2.3 Details of such materials should be provided as early as possible. Outline information concerning the proposed materials will be expected as part of any pre-planning application discussions.

### H.2 CARRIAGEWAY MATERIALS

#### H.2.1 Blacktop

- H.2.1.1 This falls into three main types
- Stone mastic asphalt
  - Hot rolled asphalt with chippings
  - Dense/close graded surface course.
- H.2.1.2 These materials provide a good running surface and combined with the correct aggregate gives acceptable skidding resistance properties. Combined with good quality paving and kerbing they provide an acceptable and serviceable surface, particularly in urban areas with higher traffic flows. Large areas of this material can, however, detract from the appearance of a public spaces.

## H.2.2 Block Paving

### H.2.2.1 Acceptable options

- Coloured concrete blocks
- 'Tegula' – tumbled concrete blocks.

H.2.2.2 Concrete block paving can provide an attractive alternative to blacktop. It is particularly useful to define less traffic dominated areas and to break up otherwise large areas of blacktop.

H.2.2.3 Plain concrete blocks are readily available in a variety of colours such as red, brindle and charcoal. As an alternative a tumbled concrete block can give a more random appearance using the range of different sizes, but with a common laying width. Care should be taken to ensure a contrast with all kerbing to assist the partially sighted and guide dogs to detect the kerb edge.

#### Alternatives

H.2.2.4 Other options exist such as:

- Imprinted asphalt
- Resin bonded surfaces
- Coloured asphalt
- Natural stone setts
- Timber decking (in very specific circumstances)

In these cases the use of such materials would require submission through the adoption process described in [sub-section 4H.1](#) above.

#### Parking Bays

H.2.2.5 Where parking bays are specified the surfacing material has the same options as carriageway surfacing. From a practical perspective if concrete blocks are used they should be of a darker colour to cover oil staining etc. Care should be taken to ensure a good edge restraint between any blocks and blacktop, such as a dropped kerb or channel block to prevent distortion in the block paved area.

#### Unsuitable Materials

H.2.2.6 Materials which leave loose aggregates or create uneven surfaces will not be acceptable as they cause problems for people with mobility issues, prams and cycles.

## H.3 FOOTWAYS AND OTHER PAVED AREAS

### H.3.1 Blacktop

These materials are generally of the dense/close graded type. Such material provides a very flexible option. It is also relatively cheap and easy to maintain, especially if there are significant amounts of services in the footways.

### H.3.2 Block Paving

#### H.3.2.1 Acceptable options

- Coloured concrete blocks
- Tegula tumbled concrete blocks.

Concrete block paving can provide an attractive alternative to blacktop. In footways and paved areas the blocks have a pencil edge.

#### H.3.2.2 Concrete flags

- Plain concrete
- Textured concrete
- Smooth/ground concrete

- Exposed aggregate.

H.3.2.3 There is a variety of finishes and colours available that can be used in a variety of layouts/coursing. The use of flags is not suitable where over-run by vehicles is likely unless use is made of fibre reinforced flags. In the latter case advice should be sought from the Highways Adoptions officer.

#### **Natural flags/setts**

H.3.2.4 If the use of natural stone flags/setts is being considered advice should be sought from the Highways Adoptions officer concerning both the type and source of the stone and the detailed specification for the bedding and jointing materials.

#### **Tactile Flags**

H.3.2.5 At uncontrolled crossing locations buff tactile paving should be detailed, naturally precast concrete flags in standard size. For controlled crossings the tactile paving should be red. The Department for Transport (DfT) produce guidance on the use of such paving and care should be taken to balance the need for paving and visual intrusion. In natural material areas alternatives exist such as specially ground flags and brass studs. Again the use of such materials needs to be submitted through the approvals process.

#### **Alternatives**

H.3.2.6 Clay blocks provide another option but advice should be sought from the Highways Adoptions officer and approval sought.

#### **Cycle Paths**

H.3.2.7 The Local Authorities do not normally require different materials for Cycle Paths. This applies to both on and off carriageway Paths. Only in limited circumstances would a red surface be required, which would normally be achieved by using a red asphalt surfacing, or red coloured blocks. Advice should be sought from the Council's Transport Planning Team to determine when this treatment is required.

## **H.4 Kerbs, channel blocks and edgings**

### **H.4.1 Concrete**

H.4.1.1 Acceptable options:

- Standard precast kerbs (grey, pressed)
- Exposed aggregate kerbs
- Plasmobility (block paving) kerb.

H.4.1.2 Standard grey precast kerbs, channel blocks and edgings form the most basic, cost effective option. Other concrete options are available, however, such as granite aggregate kerbs or exposed aggregate/textured finished kerbs. When laid upright these should be the half-batter type. In some locations laying kerbs with a broad top (or 'on their back') can give a strong visual appearance. In this case the kerbs should be of the bull-nosed type. In all cases it is important to achieve a contrast in colour between paved areas, kerbs and carriageways to assist partially sighted to differentiate the kerb 'edge' safely.

H.4.1.3 An alternative kerb suitable for use with block paving is the plasmobility kerb which is suitable for use by people with disabilities/wheelchair users. Advice on its use and suitability should be sought from the Highways Adoptions officer.

### **H.4.2 Natural**

If natural stone kerbs, channels and edging are proposed then approval needs to be sought through the process described in [sub-section 4H.1](#) above.

### **H.4.3 Unsuitable**

The use of kerb drainage units is discouraged due to maintenance issues. Advice should be sought from the Highways Adoptions officer regarding drainage issues.

## 4I Signage and street furniture

Ideally the design of signage and street furniture, as with lighting, will be undertaken as a collaborative effort between the Local Authority and the applicant's design team. The aim should be to ensure that the schemes are coordinated with other elements of the street space and avoids redundant elements, conflicts and clutter. Details of the final scheme may be subject to approval by planning condition.

### I.1 Signage

- I.1.1 As far as possible use the overall design of the street to make it obvious how the space should be used in order to avoid unnecessary use of signage.
- I.1.2 Use signage only to fulfil legal requirements and provide essential information not obvious from other sources.
- I.1.3 Minimise the number of signposts required by attaching several signs to a single post. Seek to use existing posts before adding a new one.
- I.1.4 As far as possible attach signs to walls and buildings.
- I.1.5 Please seek advice from a local highway authority officer on legal requirements and consult the *Traffic Signs Manual* Chapter 7, The Design of Traffic Signs as well as *Streets for All-Yorkshire & Humber* (EH, DfT March 2005).

### I.2 Street furniture

- I.2.1 Consider and plan for utilities and other equipment at the concept stage to ensure supply and access boxes are integrated into the scheme and do not create obstacles or clutter the public realm.
- I.2.2 Account must be taken of the needs of all different ages and abilities in specifying street furniture, in particular seating. Follow the principles of inclusive design as advocated by CABE:
  - Place people at the heart of the design process
  - Acknowledge diversity and difference
  - Offer choice where a single design cannot accommodate all users
  - Provide for flexibility of use
  - Ensure buildings and environments are convenient and enjoyable to use for everyone.
- I.2.3 All street furniture should be located clear of pedestrian routes in a 'logical' and predictable layout, inclusively designed and distinguishable by colour contrast from the backgrounds it is viewed against. Details are given in *Inclusive Mobility*.
- I.2.4 Benches with seatbacks and armrests and spaces for wheelchair and scooter users should be introduced at regular intervals to provide opportunities to rest. This will help ensure that streets are accessible to people of all abilities.
- I.2.5 Specify simple, high quality street furniture and signage that is appropriate to the character of the area. Street furniture as well as buildings should share characteristics with the locality in order to maintain character. Traditional materials are more likely to be suited to rural locations and contemporary styles more suited to central urban areas.

I.2.6 The position and specification of street furniture, including lamp standards, street signs, litter bins and benches should avoid the creation of street clutter which reduces the visual quality of the street and may obstruct footways.

I.2.7 Street furniture should be:

- Simple
- Unobtrusive
- High quality
- Fit for purpose
- Coordinated in terms of construction, materials and colour.

Minimise the number of different types, colours and materials.

Refer to [Section 4H](#) on materials for further information.

## 4J Adoption of highways

### J.1 Adoption policy

J.1.1 The policy throughout South Yorkshire is that all residential developments should be designed to the standards and specification of the Authority in order that the streets may be adopted as publicly maintained highways.

J.1.2 This applies to all streets except those agreed to remain as private drives serving up to 5 dwellings. The adoption will include all signs, lighting, highway drainage and street furniture.

Footpaths and cycleways away from carriageways will be adopted where the route is likely to be used by the public and is part of a link within a network.

### J.2 Verges, visibility splays and service strips

J.2.1 Verges and other planted areas which are an integral part of the highway design will be adopted. Special features and areas which enhance the quality of the environment will be considered for adoption providing it is in the public interest.

J.2.2 All amenity planting (including trees) will be subject to a separate agreement for which there will be a commuted sum for future maintenance.

J.2.3 Areas required for visibility at junctions or on bends will normally be adopted but in some circumstances sight lines over unadopted land, will be acceptable, secured through a covenant.

J.2.4 Car parking bays which are within the highway limits and are for general use will be adopted. Private parking areas must be located and clearly defined outside the adoptable highway boundary.

### J.3 Street lighting

J.3.1 A system of street lighting shall be required for all new adopted highways. The developer shall be responsible for all lighting maintenance until the final certificate of completion is issued. For further information on Street Lighting refer to [Section 4E Street Lighting](#). The developer will not be responsible for energy charges if the lighting has been erected by the Highway Authority.

### J.4 Drainage

J.4.1 All highway drainage will be adopted. Any surface run off from within the curtilage of private property should not normally discharge into the highway system of drainage. Separate connections should be made by the developer directly to the public surface water system if necessary.

J.4.2 SuDS features may be acceptable for adoption in certain circumstances provided consent has been obtained from the Land Drainage Authority/SuDS Approval Authority or the Environment Agency. For further information on the design requirements see [4C Drainage](#).

### J.5 Highway structures

J.5.1 All structural works including retaining walls, embankments, culverts which support or abut the highway or may effect its stability must be designed to current standards and be approved by the Highway Authority.

J.5.2 As far as possible embankments should be used to avoid the use of supporting retaining walls.

J.5.3 Any bridges or structures over a highway will not be adopted unless the structure itself carries a highway.

J.5.4 For further information on Structures refer to [Section 4D](#).

## J.6 Advance Payments Code/Section 38 Agreements

### Advance Payments Code (APC) Procedure

- J.6.1 The creation of private streets is to be avoided and this can be achieved by the correct application of the APC procedure (as detailed in the Highways Act 1980). This is a statutory tool which provides for the future making up of private streets. The required practice is for the rigorous application of the APC procedure.

### APC Procedure

- J.6.2 Within six weeks of either Building Regulation approval being granted or an Initial Notice (issued by the NHBC) being received by the Council, the Highway Authority shall serve a notice under Section 220 of the Highways Act 1980 specifying the amount to be deposited or secured in respect of the street works charges for those dwellings for which approval has been granted.
- J.6.3 Notices served, payment made or security given are registrable as a local land charge with the local Council.
- J.6.4 If the Highway Authority has served a Section 220 notice, no work may be performed to erect the dwelling (including foundations) until the sum specified in the Section 220 notice has been deposited or otherwise secured to the satisfaction of the Highway Authority. Any building works commenced before the advanced payment is made will result in enforcement by way of prosecution.
- J.6.5 It is usual for Developers to discharge their obligations under the APC by completing an Agreement with the Highway Authority under Section 38 of the Highways Act 1980. Even though it is proposed to complete such an agreement, it is still an offence to commence building works (including foundations) before the agreement is executed.
- J.6.6 A Developer who wishes to start building before the agreement is executed should either make a deposit, or provide the necessary security, in accordance with the Section 220 notice. This amount may be broken down, on request, to cover individual dwellings. Deposits made in this way will, upon completion of the agreement, be refunded to the Developer together with all accrued interest.

### Form of security

- J.6.7 The Highways Act 1980 does not specify the form of security to be given and it is for the street works authority to decide what form the security should take. The Highway Authority has decided that the following securities are acceptable in lieu of a cash deposit:
- Mortgage or second mortgage on the development land
  - A refundable bond. The bond must be in the standard form acceptable to the Highway Authority.

## J.7 Section 38 Agreement of the Highways Act 1980

### Procedure

Where a Developer wishes to complete an Agreement for the development site under Section 38 of the Highways Act 1980, and when detailed planning consent has been granted, applications should be made to the appropriate Highway Authority.

- J.7.2 The Developer will need to prove title to the land which will be the subject of a Section 38 Agreement, or provide Defective Title Indemnity Insurance and demonstrate a right to discharge surface water from the highway to either a water course, existing or proposed public sewer. Where it is proposed to drain the new highway into a sewer which is to be the subject of a Section 104 Agreement of the Water Industry Act 1991, then that Agreement must be completed with the Water Authority.

- J.7.3 In the development of some sites, it will be necessary to alter the existing public highway and these works may be the subject of a separate Agreement under the provisions of Section 278 of the Highways Act 1980.
- J.7.4 The time taken to enter into such an Agreement is likely to be lengthy and the developer should take account of this when programming the works.
- J.7.5 The Section 38 Agreement will cover neither foul sewers nor any landscape areas which are outside the highway limits to be adopted by the Highway Authority.

#### Drawings required

- J.7.6 Initially, the following drawings should be submitted in duplicate for approval:
- A plan to at least 1:500 scale showing the junction between the proposed highway and the existing public highway
  - A layout plan at 1:500 scale showing proposed adoption limits
  - A layout plan at 1:500 scale showing proposed street lighting together with calculations and data sheets (unless the scheme is to be implemented by the Highway Authority)
  - A layout plan, scale 1:500, or to a larger scale may be required, showing positions of carriageways (including carriageway widening), footways, footpaths, service margin strips, verges, traffic calming features, highway structures, visibility splays, surface water drainage details, positions of dwellings and other buildings, parking spaces, garages and vehicle crossings, street lighting, street nameplates, trees and planting etc., and defining by spot levels the falls in turning spaces and on private drives
  - A typical cross-section, showing carriageway and footway specifications, camber or crossfall gradient, kerb type, bedding and upstand, etc.
  - Longitudinal sections, showing existing and proposed levels, gradients, vertical curves, surface water and foul drainage, manholes, etc. pipe and pipe bedding classifications should also be included on these drawings for any highway drainage
  - Cross sections as may be necessary to indicate proposals for dealing with areas of cut or fill
  - Other drawings as necessary to detail surface water manholes, outfall structures, interceptors, soakaways, retaining walls and other highway structures, etc.
- J.7.8 All the layout drawings submitted for inclusion in a Section 38 Agreement must be coloured as follows:
- Carriageway - coloured brown
  - Footway - coloured yellow
  - Verges - green
  - All highway surface water drainage items - blue (including gully connections)
  - Site boundary - edged red.
- J.7.9 After approval, the relevant Highway Authority will notify the developer of the drawings required to support the Agreement.
- J.7.10 For large developments, it is recommended that the layout be divided into stages and that separate Agreements be completed for each stage.
- J.7.11 When the detailed proposals have been approved, the drawings will be passed to the appropriate Legal Officer who will prepare a draft Agreement which will be passed to the Developer's solicitor for approval. Once the draft has been approved the engrossment will be prepared and dispatched for execution by the parties to the Agreement.

J.7.12 Only when a Developer and his Surety have executed and returned the engrossment to the appropriate Legal Officer may building works commence on the dwellings unless a deposit or security has been made. The Agreement will not be revealed on Local Searches until it has been executed by all parties and completed. Developers are advised to ensure that any road works undertaken comply with the plan/s approved by the appropriate Highway Authority and that they are inspected by the Authority's representative.

#### **Completion Certificates, Surety and Inspection Charges**

J.7.13 Three Certificates will be issued under the Agreement.

- The Part I Certificate, on completion of all works comprised in Part I of the Schedule to the Agreement
- The Part II Certificate, on completion of all remaining works comprised in Part II of the Schedule to the Agreement
- The Final Certificate, on completion of any remedial works at the end of the Maintenance period specified in the Section 38 Agreement.

J.7.14 The extent of the Sureties obligations under the Agreement will be the Engineer's total estimated costs of all Works comprised in the Agreement. The sureties obligations will be reduced by 50% of the original surety value upon the issue of the Part I Certificate and reduced by a further 25% of the original surety value upon the issue of the Part II Certificate. The sureties obligations will reduce to nil upon the issue of the Final Certificate. On the issue of the Part II Certificate the road(s) will become highways, open to public use, but maintained at the developer's expense. On the issue of the Final Certificate the road(s) will become maintainable by the Highway Authority.

J.7.15 If the site is also the subject of a Section 104 Agreement under the Water Industry Act 1991 and the sewer is situated within the highway or is an integral part of the highway drainage system, then the Part II Certificate will only be issued after a 'Provisional Certificate' has been issued by the Water Authority for the works which are the subject of the 104 Agreement.

J.7.16 Planting areas to be adopted under the Section 38 Agreement must be fully established before the Part II Certificate is issued and the areas shall be maintained weed free by the Developer during the maintenance period and until the Final Certificate is issued.

J.7.16 The Final Certificate will only be issued when:

- The transfer of the 'highway' land has been completed
- All necessary Deeds of Grant for drainage or street lighting situated outside the highway limits have been completed
- Planting areas that are to be adopted are fully established and planted in accordance with the specification. If the Developer defaults on the maintenance aspect and there is a need to re-plant, adoption will be delayed until the planting is fully established or alternatively the developer pays a commuted sum to the Highway Authority so that adequate maintenance can be given in the early years. If more than 20% of planting has to be replaced before final adoption, then the developer will be required to extend his liability for maintenance for a further period to be agreed with the Highway Authority
- A Health and Safety File, as required by the Construction (Design and Management) Regulations 1994, has been delivered to the Highway Authority
- All other requirements of the Section 38 Agreement have been fully complied with.

J.7.17 The Agreement will provide for the payment to the Highway Authority of costs associated with the works and these will be detailed in the Agreement. Additional commuted sums will be necessary for the future maintenance of adopted highway structures and other items as set out in this section.

J.7.18 The Agreement will contain a clause stating that no dwelling shall be occupied until all works specified in Part I of the schedule to the Agreement up to and including the frontage of the property in question and connecting it to a highway maintainable at public expense have been completed and approved. In some circumstances, the connecting street may itself be subject to a Section 38 Agreement.

#### **Payments to the Highway Authority**

J.7.19 A charge is made by the Highway Authority for the work involved in the preparation and administration of the Section 38/278 Agreements and for checking the design and site inspection of the roadways and any associated structures.

J.7.20 The charge for administration, checking and site inspection is normally a fixed percentage (6½%) of the estimate costs of the highway works and associated structures as assessed by the Highway Authority, plus an additional fixed sum per agreement (plus disbursements) to cover legal costs.

J.20 In the event of the developer not going ahead, a charge will be made by the Highway Authority to recover their abortive or additional costs for any checking of the design and preparation and administration of the Section 38/278 Agreements.

J.21 Commuted sums will normally be required for the following items:

- Trees
- Structures
- Culverts
- Grass verges
- Traffic calming
- Shrub planting
- Additional areas of adoption
- Enhanced materials
- Enhanced lighting
- Salt bins
- Drainage soakaways
- New/improved traffic signals
- Street furniture
- Signage.

The sums payable will be dependent on the specific adoption criteria of each Highway Authority.

#### **Street lighting in private areas**

J.7.22 If street lighting is to be installed on shared Private Drives it must be agreed with the Highway Authority to ensure there is no conflict with existing or new lighting on adjacent adoptable roads. The Highway Authority will need to be satisfied that the developer has made arrangements for the payment of all future energy and maintenance charges in connection with Shared Private Drives and this could be in the form of a commuted sum payment to the Highway Authority, i.e. the Highway Authority adopts the equipment.

#### **Drainage**

J.7.23 Developers should appreciate that SuDS features, where they are adopted by the Highway Authority, incur an additional maintenance risk and may involve the payment of a commuted sum to the Highway Authority.

If any adoptable highway drainage system requires pumping equipment to be installed, the Highway Authority may require the payment of a commuted sum to cover future maintenance.

## 4K Construction waste

### K.1 General

K.1.1 Dealing with waste is an essential and integral part of the overall approach to environmental sustainability and local resources. The general principles as applied to waste are as follows:

- Minimise the production of waste by good design and improved production processes
- Reuse as many of the by-products of construction (and demolition) as possible within the site and project itself
- Find a market or use for as many by-products of construction as possible. Only those materials with no further economic use should be considered 'waste'
- Set up systems to minimise the energy used in dealing with waste.

### K.2 Code for Sustainable Homes

K.2.1 The following text is taken from the November 2010 CfSH Technical Guide as an indicator of the requirements. Please refer to the most up-to-date Technical Guide.

#### Best practice

The Site Waste Management Plan (SWMP) should include procedures, commitments for waste minimisation and diversion from landfill, as well as setting target benchmarks for resource efficiency in accordance with guidance from:

- DEFRA (Department for Environment, Food and Rural Affairs)
- BRE (Building Research Establishment)
- Envirowise
- WRAP (Waste & Resources Action Programme)
- Environmental performance indicators and/or key performance indicators (KPI) from Envirowise or Constructing Excellence.

## 4L Management

### L.1 Early consideration of management responsibility

L.1.1 It is essential to identify at the outset of the project a realistic range of potential bodies that might take on the management of the various elements of the scheme. By the concept stage, appropriate management bodies must be identified to account for all the land within the proposal. This information must be submitted as part of both the concept stage submission and final submission.

L.1.2 Streets will normally be adopted by the Local Highway Authority.

L.1.3 Other elements that must be covered by a management body include:

- Structural landscape and planting
- Allotments
- Open drainage features (see also Section 4C Drainage)
- Areas of public open space not part of the public highway
- Shared private open space
- Shared private parking areas
- Community buildings
- District energy schemes.

L.1.4 There may be others depending on the specifics of the scheme.

### L.2 Management bodies

L.2.1 The bodies identified for management must have the appropriate skills and resources to undertake the management and must have the appropriate legal status.

L.2.2 Appropriate bodies may include the following:

- Local Authority
- Parish or Town Council
- Limited company
- Community interest company
- Trust
- Commonhold association
- Unincorporated association or contractual relationship.

L.2.3 The choice of appropriate management body should be discussed and agreed with local authority officers.

### L.3 Management plans

L.3.1 Details of the management plans and programmes will be required either through a Section 106 agreement or planning conditions.

The contents of plans should be discussed and agreed with local authority officers. In most cases the plans will need to indicate the programme of management and maintenance, structure and terms of responsibilities and chain of communication.



Ap

# Appendices



# Ap1

## Core principles

New development in South Yorkshire should help to create places that are:

- **integrated**, complementary
- **vital**, active, well managed
- **equitable**, cohesive, inclusive, safe and secure
- **local**, distinctive, attractive
- **efficient**, flexible, adaptable.

These are not listed in order of priority. Rather, all are essential aspects of **sustainable** development, encompassing its social, economic and environmental dimensions.

The core principles are derived from a range of sources including national, regional and local policies, guidance and sustainability objectives. The full range of objectives is extensive and reflects the richness and diversity of the issues involved in achieving sustainable development.

One of the tasks of the guide is to translate those general objectives into more specific guidance for the people involved in delivering development. In order to do so the range of objectives has been grouped and distilled down to a workable list. The meaning of the terms set in more detail out below.

### 1.1 Integrated, complementary

**All new development must have a clearly defined role within the wider area.**

**The role will have a number of dimensions in relation to:**

- **The landscape and green infrastructure**
- **A local neighbourhood, district or main centres, facilities and services**
- **Principal lines of movement**
- **Built form and character**
- **Townscape and open space network.**

**The design should ensure that the proposal works together with elements in the wider area to create a sense of a greater whole.**

Development always occurs in a physical and social context. Everything in the built environment is part of something larger. A settlement is part of a wider landscape and social network, a house is part of a street and neighbourhood community.

Different locations in relation to elements such as green infrastructure, routes and centres present different conditions and opportunities.

As appropriate to its scale and location, development should reinforce the physical and cultural connections both between the settlement and the surrounding countryside and within the settlement. Development should help to create or contribute to the sense of a neighbourhood as a whole that has a centre, both physical and social.

## 1.2 Vital, active, well managed

**New development should have easy access to or include essential non-residential uses, facilities and services.**

**The proposed uses, layout and design of new development should foster and encourage active use of the public realm appropriate to its location.**

**All parts of a proposal should have a definite purpose, including multi-functional elements, and the responsibility for each element should be clearly identified from the outset.**

The most successful places are those that have a sense of vitality, whether a busy centre or restful green space. The sight of people using a space or coming or going tends to attract other people and helps to make places safer.

The core of vitality is a complementary relationship between residential and non-residential uses including employment, services and facilities, education, leisure and health.

Places that are vital show evidence of being actively used and well looked after. Essential to vitality are good connections to other active places, the right mix of uses for a particular location, a layout that concentrates activity in the public realm, an attractive appearance and a regime of management that ensures places are well maintained.

Good management and maintenance are essential to sustain the vitality of a place. It is therefore essential to consider from the outset who will be responsible for the future management and maintenance of all elements of a scheme and the resource implications.

## 1.3 Equitable, cohesive, inclusive, safe and secure

**The design of new development should:**

- **Facilitate sociable interaction**
- **Ensure a positive and complementary balance between the public and private realms**
- **Satisfy the needs of the widest range of users and achieve the greatest good for all groups and individuals - not specializing for one to the exclusion of another**
- **Help reduce the incidence and fear of anti-social behaviour and crime.**

The success and vitality of a place is closely related to the extent to which people are easily able to meet and interact and do the things they need and want to do. The combination of interaction and accessibility helps to foster a sense of common commitment to a locality.

Communities are in turn more cohesive when all members of the community are able to interact and go about their lives on an equal basis and are as free as possible from physical and social barriers. The idea of inclusive environments has a legal basis in the Disability Discrimination Act and it is the duty of public authorities to ensure new development complies with the Act.

For an environment to be fully accessible and inclusive it must be and feel safe for the widest range of users. This includes safety and security with respect to both social and environmental factors. There is a strong mutually supporting relationship between inclusiveness, cohesion and safety. The more inclusive and cohesive an environment, the safer it is likely to be.

All new development should follow the principles of inclusive design as advocated by CABE:

- Design for people
- Acknowledge diversity and difference
- Offer choice where a single design cannot accommodate all users
- Allow for flexibility of use
- Ensure designs are convenient and enjoyable for everyone.

#### 1.4 Local, distinctive, attractive

New development should maintain or enhance the character and identity of the area in which it is located.

Rather than erasing what exists, new development should make the best of the natural and built resources on and around the site and the cultural traditions of the area. It should retain the distinctiveness of the locality.

Local identity and character are defined by a combination of more detailed characteristics. These cover a wide range, which can be grouped under the following headings as a basis for appraisal and description. More detailed indications for appraisal are found in section 3.1.

- **landscape** character/physical features/ topography /green infrastructure/ drainage
- **neighbourhood** structure and land use (centres and activities) range, location and intensity of activities
- **movement** structure (uses and hierarchy) range of modes, arrangement and intensity
- **built form** character areas/ types of development/local vernacular historic features
- **townscape**/pattern of open spaces, focal points, views/public realm/condition

The aim in new development should be to maintain local distinctiveness and character unless the character of the locality is clearly identified and viewed by most people as negative.

In order to maintain character, new development should share a sufficient number of the characteristics that define the area to demonstrate continuity of character.

There are two general means to realise the principle. One is through continuity of characteristics, using and reinterpreting forms that are typical of the area (such as street patterns, street types, plot and building types, details and materials). Another is through incorporation of the existing patterns and features of a site into new development (such as watercourses, drainage features, trees and other planting, access points, routes, buildings, boundary walls, surfaces). In both cases a detailed appraisal is an essential precursor to producing designs.

#### 1.5 Efficient, flexible, adaptable

Design solutions should seek to:

- Reduce demand for resources
- Increase efficiency of use
- Minimise use of imported resources
- Sustain and increase production of local resources (renewables) and processing of cycled resources (air and water)
- Increase multi-functionality, flexibility, adaptability, reuse and recycling of outputs
- Reduce waste (in particular carbon emissions).

With respect to energy, this translates to:

- **Priority 1:** Energy conservation  
changing wasteful behaviour to reduce demand
- **Priority 2:** Energy efficiency  
using technology to reduce demand and eliminate waste
- **Priority 3:** Exploitation of local (or if not available, non-local)  
renewable, sustainable resources
- **Priority 4:** Exploitation of local (or if not available, non-local)  
non-sustainable resources using low-carbon technologies
- **Priority 5:** Exploitation of conventional resources as we do now.

The use of resources and sustainability are best seen in terms of the materials and resources found within a locality - its local resources - and the 'inputs' and 'outputs' to and from it to sustain our quality of life.

What is necessary to sustain the development within the wider structure?

An essential precursor to answering that question is to undertake an appraisal of the local resources to determine which solutions are the most effective and appropriate for the locality and make best use of the resources available.

It should also be recognised that solutions operate at and can be better suited to different scales.

New development itself should not be seen as a solution to a short term need but as a resource for the long term life of the community.

# Ap2

## Table of supporting policies

The following table sets out the policies from each of the four authorities that support the guidance contained in this document. The relevant policy documents from each authority are as follows

- **Barnsley Metropolitan Borough Council**  
Barnsley Local Development Framework Core Strategy, Publication Version, February 2010 (CS-PV 2010)
  - **Doncaster Metropolitan Borough Council**  
Unitary Development Plan, Adopted July 1998 (UDP 1998)
  - **Rotherham Metropolitan Borough Council**  
Unitary Development Plan, Adopted June 1999 (UDP 1999)
  - **Sheffield City Council**  
Core Strategy, Adopted March 2009  
City Policies and Sites (Consultation Draft Version).
-

GUIDELINE	POLICY TOPIC	BMBC	DMBC	RMBC
		CS-PV 2010	UDP 1998	UDP 1999
N1	Neighbourhoods and centres	<p><b>CSP13</b> - The Release of Allocated Land,</p> <p><b>CSP37</b> - Landscape character</p>	<p><b>SCF3</b> - New Community Facilities (UDP pg 29)</p> <p><b>SRL1</b> - Open Space (UDP pg 28)</p> <p><b>RL4</b> - Open Space Policy Areas (UDP pg 178)</p>	<p><b>ENV3.1</b> - Development &amp; the Environment</p> <p><b>ENV5.1</b> - Allocated Urban Greenspace</p> <p><b>ENV5.2</b> - Incidental Urban Greenspace</p> <p><b>CR2.2</b> - Safeguarding recreation areas</p> <p><b>UDP - SPG</b> - Housing</p> <p><b>Guidance 4</b> - Requirements for Greenspace in New Housing Areas</p>
N2	Character	<p><b>CSP37</b> - Landscape Character</p>	<p><b>ENV18</b> - Landscape Conservation (UDP pg 77)</p> <p><b>ENV25</b> - Conservation Areas (UDP pg 83)</p> <p><b>ENV52</b> - Design of New Buildings (UDP pg 100)</p> <p><b>PH11</b> - Residential Uses and Residential Policy Areas (UDP pg 123)</p> <p><b>ENV59</b> - Protection of Trees (UDP pg 103)</p>	<p><b>HG1</b> - Existing Housing Areas</p> <p><b>ENV2</b> - Conserving the Environment</p> <p><b>ENV2.3</b> - Maintaining the character and quality of the environment</p> <p><b>ENV2.4</b> - Enhancing Environmental Resources</p> <p><b>ENV3.2</b> - Minimising the impact of development</p>

GUIDELINE	SCC	SCC
	Core Strategy	City Policies and Sites (Consultation Draft Version)
<b>N1</b>	<p><b>CS23</b> Locations for New Housing</p> <p><b>CS26</b> Efficient use of Housing Land and Accessibility</p> <p><b>CS43</b> Schools</p> <p><b>CS44</b> Health Centres</p> <p><b>CS45</b> Quality and Accessibility of Open Space</p> <p><b>CS46</b> Quantity of Open Space</p> <p><b>CS47</b> Safeguarding Open Space</p> <p><b>CS51</b> Transport Priorities (a), (b)</p> <p><b>CS53</b> Management Demand for Travel (b)</p> <p><b>CS54</b> Pedestrian Routes</p> <p><b>CS55</b> Cycling Routes</p> <p><b>CS61</b> Pedestrian Environment in the City Centre</p> <p><b>CS56</b> Priority Routes for Bus and Bus Rapid Transit</p> <p><b>CS63</b> Responses to Climate Change (c)</p> <p><b>CS73</b> The Strategic Green Network</p> <p><b>CS74</b> Design Principles (g)</p>	<p><b>A1</b> Infrastructure Requirements</p> <p><b>C1</b> Access to Local Services and Community Facilities in New Residential Developments</p> <p><b>C2</b> Residential Design (a), (f)</p> <p><b>C4</b> Development in District and Neighbourhood Centres</p> <p><b>D2</b> Open Space in New Developments</p> <p><b>E1</b> Travel Plans and Car Clubs</p> <p><b>E3</b> Design for Streets and Movement</p> <p><b>G2</b> Green Network</p> <p><b>G7</b> Development Affecting Conservation Areas</p> <p><b>H1</b> Land Uses in Policy Areas</p>
<b>N2</b>	<p><b>CS74</b> Design Principles</p>	<p><b>C2</b> Residential Design</p> <p><b>D1</b> Design for the Needs of All Users</p> <p><b>E3</b> Design for Streets and Movement</p> <p><b>G3</b> Trees, Woodland and the South Yorkshire Forest</p> <p><b>G4</b> Water in the Landscape</p> <p><b>G5</b> Development and Area Character</p> <p><b>G6</b> Countryside Character</p> <p><b>G7</b> Development Affecting Conservation Areas</p> <p><b>G8</b> Development Affecting Listed Buildings, Locally Important Historic Buildings, Ancient Monuments and Sites of Archaeological Interest</p> <p><b>G9</b> Historic Parks, Gardens and Cemeteries</p> <p><b>G10</b> Quality Design</p> <p><b>G11</b> Landscape and Design (Tall Buildings Policy in draft doc)</p>

GUIDELINE	POLICY TOPIC	BMBC	DMBC	RMBC
		CS-PV 2010	UDP 1998	UDP 1999
N3	Local resources, energy and carbon dioxide reduction	<p><b>CSP2</b> - Sustainable Construction,</p> <p><b>CSP3</b> - Sustainable Drainage Systems (SuDS)</p>	<p><b>ENV52</b> - Design of New Buildings (UDP pg 100)</p> <p><b>PU11</b> - River Quality and Pollution Control (UDP pg 263)</p> <p><b>PH13</b> - Residential Standards (UDP pg 124)</p>	<p><b>UTL1</b> - Safeguarding Utility Infrastructure</p> <p><b>UTL2</b> - Utility Services for new Development</p> <p><b>UTL3</b> - The Environmental Impact of Service Installations</p> <p><b>UTL3.3</b> - Energy Conservation</p> <p><b>UTL3.4</b> - Renewable Energy</p>
N4	Green infrastructure, vegetation and habitat	<p><b>CSP36</b> - Biodiversity and Geodiversity</p>	<p><b>ENV17</b> - Areas of Special Landscape Value (UDP pg 75)</p> <p><b>ENV18</b> - Landscape Conservation (UDP pg 71)</p> <p><b>ENV23</b> - Trees and Woodland (UDP pg 79)</p> <p><b>ENV42</b> - Sites of Regional/ Local Importance for Nature Conservation (UDP pg 95)</p> <p><b>ENV43</b> - New Development and Nature Conservation (UDP pg 95)</p> <p><b>ENV44</b> - Wildlife Corridors (UDP pg 97)</p>	<p><b>ENV1.1</b> - Areas of High Landscape Value</p> <p><b>ENV1.2</b> - Development in Areas of High Landscape Value</p> <p><b>ENV2.2</b> - Interest outside Statutorily Protected Sites</p> <p><b>ENV2.3</b> - Maintaining the character and quality of the Environment</p> <p><b>ENV3</b> - Borough Landscape</p> <p><b>ENV3.1</b> - Development &amp; the Environment</p> <p><b>UDP - SPG - Housing Guidance 5</b> - Landscape Design in New Housing Areas</p>

GUIDELINE	SCC	SCC
	Core Strategy	City Policies and Sites (Consultation Draft Version)
<b>N3</b>	<p><b>CS24</b> Maximising the Use of Previously Developed Land for Housing</p> <p><b>CS63</b> Responses to Climate Change</p> <p><b>CS64</b> Climate Change, Resources and Sustainable Development</p> <p><b>CS65</b> Renewable Energy and Carbon Reduction</p> <p><b>CS66</b> Air Quality</p> <p><b>CS67</b> Flood Risk Management</p> <p><b>CS70</b> Provision for Recycling and Composting</p> <p><b>CS73</b> The Strategic Green Network</p> <p><b>CS74</b> Design Principles</p>	<p><b>C2</b> Residential Design</p> <p><b>C3</b> Safeguarding Living Conditions</p> <p><b>F1</b> Pollution Control</p> <p><b>G1</b> Safeguarding and Enhancing Biodiversity</p> <p><b>G3</b> Trees, Woodland and the South Yorkshire Forest</p> <p><b>G4</b> Water in the Landscape</p> <p><b>G10</b> Quality Design</p>
<b>N4</b>	<p><b>CS24</b> Maximising the Use of Previously Developed Land for Housing</p> <p><b>CS63</b> Responses to Climate Change</p> <p><b>CS64</b> Climate Change, Resources and Sustainable Development</p> <p><b>CS65</b> Renewable Energy and Carbon Reduction</p> <p><b>CS66</b> Air Quality</p> <p><b>CS67</b> Flood Risk Management</p> <p><b>CS70</b> Provision for Recycling and Composting</p> <p><b>CS73</b> The Strategic Green Network</p> <p><b>CS74</b> Design Principles</p>	<p><b>C2</b> Residential Design</p> <p><b>C3</b> Safeguarding Living Conditions</p> <p><b>E3</b> Design for Streets and Movement</p> <p><b>F1</b> Pollution Control</p> <p><b>G1</b> Safeguarding and Enhancing Biodiversity</p> <p><b>G3</b> Trees, Woodland and the South Yorkshire Forest</p> <p><b>G4</b> Water in the Landscape</p> <p><b>G5</b> Development and Area Character</p> <p><b>G6</b> Countryside Character</p> <p><b>G7</b> Development Affecting Conservation Areas</p> <p><b>G8</b> Development Affecting Listed Buildings, Locally Important Historic Buildings, Ancient Monuments and Sites of Archaeological Interest</p> <p><b>G9</b> Historic Parks, Gardens and Cemeteries</p> <p><b>G10</b> Quality Design</p> <p><b>G11</b> Landscape and Design (Tall Buildings Policy in draft doc)</p>

GUIDELINE	POLICY TOPIC	BMBC	DMBC	RMBC
		CS-PV 2010	UDP 1998	UDP 1999
N5	Street pattern and movement structure	CSP25 - New Development and Sustainable Travel CSP27 - Parking Strategy	ENV64 - Public Safety (UDP pg 105) ENV70 - Improving the Environment (UDP pg 108) PH13 - Residential Standards (UDP pg 124) ST3 - Car Parking (UDP pg 146) ST4 - Public Transport (UDP pg 150) ST6 - Public Rights of Way (UDP pg 154) T6 - Highway Network (UDP pg 145) T15 - Public Rights of Way (UDP pg 155) T38 - Public Rights of Way (UDP pg 155) T42 - Public Rights of Way (UDP pg 156) T43 - Public Rights of Way (UDP pg 157)	Policy T3 - Public Transport Policy T4 - Traffic Management Policy T6 - Location & Layout of Development Policy T7 - Public Rights of Way Policy T8 - Access Interim Parking Standards July 2002
N6	Townscape, topography and views	CSP29 - Design Principles	ENV53 - Design of New Buildings (UDP pg 100)	ENV1.2 - Development in Areas of High Landscape Value ENV3.1 - Development and the Environment ENV2.8 - Setting and Curtilages of Listed Buildings

GUIDELINE	SCC	SCC
	Core Strategy	City Policies and Sites (Consultation Draft Version)
N5	<p><b>CS23</b> Locations for New Housing</p> <p><b>CS24</b> Maximising the Use of Previously Developed Land for Housing</p> <p><b>CS26</b> Efficient Use of Housing Land and Accessibility</p> <p><b>CS43</b> Schools</p> <p><b>CS44</b> Health Centres</p> <p><b>CS45</b> Quality and Accessibility of Open Space</p> <p><b>CS46</b> Quantity of Open Space</p> <p><b>CS47</b> Safeguarding Open Space</p> <p><b>CS51</b> Transport Priorities</p> <p><b>CS53</b> Management Demand for Travel</p> <p><b>CS54</b> Pedestrian Routes</p> <p><b>CS55</b> Cycling Routes</p> <p><b>CS56</b> Priority Routes for Bus and Bus Rapid Transit</p> <p><b>CS61</b> Pedestrian Environment in the City Centre</p> <p><b>CS63</b> Responses to Climate Change</p> <p><b>CS64</b> Climate Change, Resources and Sustainable Development</p> <p><b>CS65</b> Renewable Energy and Carbon Reduction</p> <p><b>CS66</b> Air Quality</p> <p><b>CS67</b> Flood Risk Management</p> <p><b>CS70</b> Provision for Recycling and Composting</p> <p><b>CS73</b> The Strategic Green Network</p> <p>CS74 Design Principles</p>	<p><b>A1</b> Infrastructure Requirements</p> <p><b>C1</b> Design for Sustainable Neighbourhoods (Access to Local Services and Community Facilities in New Residential Developments Policy in draft doc)</p> <p><b>C2</b> Residential Design</p> <p><b>C3</b> Safeguarding Living Conditions</p> <p><b>C4</b> Development in District and Neighbourhood Centres</p> <p><b>D1</b> Design for the Needs of All Users</p> <p><b>D2</b> Open Space in New Developments</p> <p><b>E1</b> Travel Plans and Car Clubs</p> <p><b>E2</b> Parking Requirements (referred to as Parking in draft doc)</p> <p><b>E3</b> Design for Streets and Movement</p> <p><b>F1</b> Pollution Control</p> <p><b>G1</b> Safeguarding and Enhancing Biodiversity</p> <p><b>G2</b> Green Network</p> <p><b>G3</b> Trees, Woodland and the South Yorkshire Forest</p> <p><b>G4</b> Water in the Landscape</p> <p><b>G5</b> Development and Area Character</p> <p><b>G6</b> Countryside Character</p> <p><b>G7</b> Development Affecting Conservation Areas</p> <p><b>G8</b> Development Affecting Listed Buildings, Locally Important Historic Buildings, Ancient Monuments and Sites of Archaeological Interest</p> <p><b>G10</b> Quality Design</p> <p><b>G11</b> Landscape and Design (Tall Buildings Policy in draft doc)</p> <p><b>H1</b> Land Uses in Policy Areas</p>
N6	<p><b>CS74</b> Design Principles</p>	<p><b>C2</b> Residential Design</p> <p><b>D1</b> Design for the Needs of All Users</p> <p><b>E3</b> Design for Streets and Movement</p> <p><b>G3</b> Trees, Woodland and the South Yorkshire Forest</p> <p><b>G4</b> Water in the Landscape</p> <p><b>G5</b> Development and Area Character</p> <p><b>G6</b> Countryside Character</p> <p><b>G7</b> Development Affecting Conservation Areas</p> <p><b>G9</b> Historic Parks, Gardens and Cemeteries</p> <p><b>G10</b> Quality Design</p> <p><b>C2</b> Residential Design</p>

GUIDELINE	POLICY TOPIC	BMBC	DMBC	RMBC
		CS-PV 2010	UDP 1998	UDP 1999
S1	The street as a whole	SPG2- Relationship with existing dwellings and space between proposed dwellings.		<p><b>Policy HG1</b> - Existing Housing Areas</p> <p><b>ENV1.2</b> - Development in Areas of High Landscape Value</p> <p><b>ENV2.3</b> - Maintaining the Character and Quality of the Environment</p> <p><b>HG4.4</b> - Back Land and Tandem Development</p> <p><b>HG5</b> - The Residential Environment</p> <p><b>UDP - SPG - Housing Guidance 2:</b> Back Land and Tandem Development</p> <p><b>UDP - SPG - Housing Guidance 3:</b> Residential Infill Plots</p>
S2	Street spaces and the public realm	CSP3 - Sustainable Drainage Systems (SuDS)	<p><b>ENV63</b> - Public Art (UDP pg 105)</p> <p><b>ENV64</b> - Public Safety (UDP pg 105)</p> <p><b>ST3</b> - Car Parking (UDP pg 100)</p>	<p><b>ENV3.1</b> - Development and the Environment</p> <p><b>T8</b> - Access</p> <p><b>T2</b> - Major Road Schemes and Highway Improvements</p> <p><b>T4</b> - Traffic Management</p> <p><b>UTL2</b> - Utility Services for New Development</p> <p><b>Interim Parking Standards</b> July 2002</p> <p><b>UDP - SPG - Housing Guidance 5</b> - Landscape Design in New Housing Areas</p>

GUIDELINE	SCC	SCC
	Core Strategy	City Policies and Sites (Consultation Draft Version)
<b>S1</b>	<p><b>CS51</b> Transport Priorities</p> <p><b>CS53</b> Management of Demand for Travel</p> <p><b>CS54</b> Pedestrian Routes</p> <p><b>CS55</b> Cycling Routes</p> <p><b>CS61</b> Pedestrian Environment in the City Centre</p> <p><b>CS74</b> Design Principles</p>	<p><b>C1</b> Design for Sustainable Neighbourhoods (Access to Local Services and Community Facilities in New Residential Developments Policy in draft doc)</p> <p><b>C2</b> Residential Design</p> <p><b>D1</b> Design for the Needs of All Users</p> <p><b>D2</b> Open Space in New Developments</p> <p><b>E3</b> Design for Streets and Movement</p> <p><b>G3</b> Trees, Woodland and the South Yorkshire Forest</p> <p><b>G4</b> Water in the Landscape</p> <p><b>G5</b> Development and Area Character</p> <p><b>G6</b> Countryside Character</p> <p><b>G7</b> Development Affecting Conservation Areas</p> <p><b>G10</b> Quality Design (a, b, c, f, h)</p>
<b>S2</b>	<p><b>CS51</b> Transport Priorities</p> <p><b>CS53</b> Management of Demand for travel (b)</p> <p><b>CS54</b> Pedestrian Routes</p> <p><b>CS55</b> Cycling Routes</p> <p><b>CS61</b> Pedestrian Environment in the City Centre</p> <p><b>CS74</b> Design Principles (e, f, g, h)</p>	<p><b>C1</b> Design for Sustainable Neighbourhoods (Access to Local Services and Community Facilities in New Residential Developments Policy in draft doc)</p> <p><b>C2</b> Residential Design</p> <p><b>D1</b> Design for the Needs of All Users</p> <p><b>D2</b> Open Space in New Developments</p> <p><b>E1</b> Travel Plans and Car Clubs</p> <p><b>E2</b> Parking Requirements (referred to as Parking in draft doc)</p> <p><b>E3</b> Design for Streets and Movement (d, l)</p> <p><b>G10</b> Quality Design (a, b, c, f, h)</p>

GUIDELINE	POLICY TOPIC	BMBC	DMBC	RMBC
		CS-PV 2010	UDP 1998	UDP 1999
B1	Plot series and streets	<p><b>CSP14</b> - Housing Mix and Efficient Use of Land</p> <p><b>SPG2</b> - Density</p> <p><b>CSP27</b> - Parking Strategy'</p> <p><b>SPG2</b> - Car Parking Requirements</p>	<p><b>PH11</b> - Residential Uses and Residential Policy Areas (UDP pg 123),</p> <p><b>PH13</b> - Residential Standards (UDP pg 124)</p>	<p><b>ENV3.1</b> - Development and the Environment</p> <p><b>T6</b> - Location and Layout of Development</p> <p><b>Interim Parking Standards</b> July 2002</p>
B2	Buildings in their plots		<p><b>PH13</b> - Residential Standards (UDP pg 124),</p> <p><b>ENV64</b> - Public Safety (UDP pg 105),</p> <p><b>ENV70</b> - Improving the Environment (UDP pg 108)</p>	<p><b>HG4.5</b> - Special Needs Housing</p> <p><b>HG5</b> - The Residential Environment</p> <p><b>HG4.7</b> - Affordable Housing - updated by Affordable Housing Interim Planning Statement June 2008</p> <p><b>UDP - SPG - Housing</b></p> <p><b>Guidance 4</b> - Requirements for Greenspace in New Housing Areas</p> <p><b>UDP - SPG - Housing</b></p> <p><b>Guidance 7</b> - Security</p>

GUIDELINE	SCC	SCC
	Core Strategy	City Policies and Sites (Consultation Draft Version)
<b>B1</b>	<p><b>CS41</b> Creating Mixed Communities</p> <p><b>CS53</b> Management of Demand for Travel</p> <p><b>CS74</b> Design Principles</p>	<p><b>C2</b> Residential Design</p> <p><b>C1</b> Design for Sustainable Neighbourhoods (Access to Local Services and Community Facilities in New Residential Developments Policy in draft doc)</p> <p><b>D1</b> Design for the Needs of All Users</p> <p><b>E3</b> Design for Streets and Movement (e)</p> <p><b>E3</b> Design for Streets and Movement (d, l)</p> <p><b>G3</b> Trees, Woodland and the South Yorkshire Forest</p> <p><b>G4</b> Water in the Landscape</p> <p><b>G5</b> Development and Area Character</p> <p><b>G6</b> Countryside Character</p> <p><b>G7</b> Development Affecting Conservation Areas</p> <p><b>G8</b> Development Affecting Listed Buildings, Locally Important Historic Buildings, Ancient Monuments and Sites of Archaeological Interest</p> <p><b>G9</b> Historic Parks, Gardens and Cemeteries</p> <p><b>G10</b> Quality Design</p> <p><b>G11</b> Landscape and Design (Tall Buildings Policy in draft doc)</p> <p><b>H1</b> Land Uses in Policy Areas (not included in draft document)</p>
<b>B2</b>	<p><b>CS24</b> Maximising the Use of Previously Developed Land for Housing</p> <p><b>CS41</b> Creating Mixed Communities</p> <p><b>CS53</b> Management of Demand for Travel</p> <p><b>CS63</b> Responses to Climate Change</p> <p><b>CS64</b> Climate Change, Resources and Sustainable Development</p> <p><b>CS65</b> Renewable Energy and Carbon Reduction</p> <p><b>CS66</b> Air Quality</p> <p><b>CS67</b> Flood Risk Management</p> <p><b>CS70</b> Provision for Recycling and Composting</p> <p><b>CS73</b> The Strategic Green Network</p> <p><b>CS74</b> Design Principles</p>	<p><b>C2</b> Residential Design</p> <p><b>C3</b> Safeguarding Living Conditions</p> <p><b>D1</b> Design for the Needs of All Users</p> <p><b>E3</b> Design for Streets and Movement</p> <p><b>F1</b> Pollution Control</p> <p><b>G1</b> Safeguarding and Enhancing Biodiversity</p> <p><b>G3</b> Trees, Woodland and the South Yorkshire Forest</p> <p><b>G4</b> Water in the Landscape</p> <p><b>G5</b> Development and Area Character</p> <p><b>G6</b> Countryside Character</p> <p><b>G7</b> Development Affecting Conservation Areas</p> <p><b>G10</b> Quality Design</p> <p><b>H1</b> Land Uses in Policy Areas (not included in draft document)</p>

GUIDELINE	POLICY TOPIC	BMBC	DMBC	RMBC
		CS-PV 2010	UDP 1998	UDP 1999
B3	Building design		PH11 - Residential Uses and Residential Policy Areas (UDP pg 123), PH13 - Residential Standards (UDP pg 124)	HG5 - The Residential Environment ENV2.11 - Development in Conservation Areas ENV3.1 - Development and the Environment ENV3.2 - Minimising the Impact of Development UDP - SPG - Environment Guidance 2 - Alterations to Listed Buildings UDP - SPG - Environment Guidance 3 - Development in Conservation Areas
4A.1	Amenity space	SPG2- Private gardens and front gardens		UDP - SPG - Housing Guidance 4 – Requirements for Greenspace in New Housing Areas

GUIDELINE	SCC	SCC
	Core Strategy	City Policies and Sites (Consultation Draft Version)
<p><b>B3</b></p>	<p><b>CS24</b> Maximising the Use of Previously Developed Land for Housing  <b>CS63</b> Responses to Climate Change  <b>CS64</b> Climate Change, Resources and Sustainable Development  <b>CS65</b> Renewable Energy and Carbon Reduction  <b>CS66</b> Air Quality  <b>CS67</b> Flood Risk Management  <b>CS70</b> Provision for Recycling and Composting  <b>CS73</b> The Strategic Green Network  <b>CS74</b> Design Principles</p>	<p><b>C1</b> Design for Sustainable Neighbourhoods (Access to Local Services and Community Facilities in New Residential Developments Policy in draft doc)  <b>C2</b> Residential Design  <b>C3</b> Safeguarding Living Conditions  <b>E3</b> Design for Streets and Movement  <b>F1</b> Pollution Control  <b>G1</b> Safeguarding and Enhancing Biodiversity  <b>G3</b> Trees, Woodland and the South Yorkshire Forest  <b>G4</b> Water in the Landscape  <b>G5</b> Development and Area Character  <b>G6</b> Countryside Character  <b>G7</b> Development Affecting Conservation Areas  <b>G10</b> Quality Design</p>



# Ap3

## Glossary of terms

### **Accessibility**

A term often used interchangeably with inclusive design to describe the extent to which a product or environment can be reached and is usable by the widest range of people but in particular the elderly and disabled.

### **Active frontage or edge**

The ground floor of a building animated by the presence of people either entering or leaving buildings or by the visibility of activities within the building from the street. An active edge is generally achieved by concentrating windows and doors fronting directly onto the street.

### **Adopted public highway**

That part of a road or street that is maintained by the Local Highway Authority for public use at public expense. In general the adopted highway includes the vehicle carriageway, footways and any verge.

### **Affordable Housing**

Low cost or subsidised housing for sale or rent intended to meet the needs of local people who cannot afford accommodation through the open or low cost market. Affordable housing is often provided by a housing association acting as a Registered Social Landlord.

### **Biomass**

Plant material, usually wood, burned to generate heat and in some cases electricity.

### **Block(or street-block)**

An area of land defined by streets, generally occupied by buildings.

### **Building for Life standard**

A framework for assessing the quality of new housing and neighbourhoods. The standard is based on a set of twenty design criteria posed as questions about the design of a development. See Sections 1.6 and Section 2 for more detail.

### **Building line**

The line formed by the front of buildings with a common set-back along a street.

### **Centre**

A group or cluster of non-residential uses such as shops and service outlets serving part of an urban area or settlement and providing a geographic focus for it. Centres are usually given a place in a hierarchy according to their size and the catchment they serve – i.e. neighbourhood (local), district and main (town or city).

### **Character**

The sense and identity of a place that comes from its unique set of features, characteristics and form, including the underlying natural features, man-made features such as settlements, streets and buildings, as well as the activities that go on in them.

---

**Code for Sustainable Homes**

A national standard for the sustainable design and construction of new homes. The standard was launched in December 2006 and is set to be progressively adopted as part of the national Building Regulations.

**Combined heat and power**

Mechanical boiler systems for generating both heat and electricity at the same time from a single fuel source.

**Community focal point**

A physical area or place 'where paths cross' and people might meet, stop and carry on a conversation.

**Conservation Area**

An area designated as being of special architectural or historic interest, where the preservation and enhancement of its character and appearance is a priority. Within a conservation area the local authority has extra controls over demolition, minor developments and works to trees.

**Context**

The setting or surroundings of a site, including factors such as traffic, activities and land uses as well as landscape and existing buildings.

**Cul-de-sac**

A street with only one way in and out.

**Density**

A measurement of the amount of residential development within a given area. For planning purposes density is usually calculated in either dwellings per hectare (dph) or habitable rooms per hectare (hrh), excluding land for other uses and major or strategic roads and landscape (referred to as 'net density', see PPS3, Annex B).

**Design speed**

The maximum speed at which a motor vehicle can be operated safely on a street (in perfect conditions) due to the physical design of the street. See **Speed limit**

**Desire line**

A pedestrian's preferred line of movement between two points; generally the most direct and convenient route.

**Edge**

The boundary between two areas with different character. Edges often correspond to natural features such as rivers, steep slopes and shorelines.

**Elevation**

A façade of a building, or the drawing of a façade.

**Enclosure**

The definition or bounding of a space by physical features such as buildings or trees.

**Form**

The physical structure or arrangement of a settlement described variously in terms of: street pattern or layout, plot pattern, building pattern, building type, density, size (height and massing) materials and details (appearance) and landscape planting of a development.

**Frontage (line)**

The boundary between a plot of land and the public highway.

**Fronts and backs**

The distinction of different sides of buildings defined in terms of the main entrance or 'public' face of the building. The front is the active, public side and is used as the main address of the building. In general the front should face the frontage line.

**Gateway**

A feature or arrangement of features such as trees, walls or buildings that mark the entrance into a distinct area.

**Green infrastructure**

The existing or planned network of green spaces and natural features in an area including parks, open spaces, playing fields, woodlands, allotments and private gardens as well as accessible countryside. As 'infrastructure' the network should be conceived and managed as a multifunctional resource.

**Ground source heat**

A form of renewable heat energy extracted from the ground through the use of pumps and heat exchangers. It is necessary to use some electricity to get the additional heat energy. The systems can also be used for cooling.

**Habitable rooms**

The main living areas within a residential building, including bedrooms, sitting rooms and dining rooms. Bathrooms and kitchens (smaller than 13 m<sup>2</sup>) are excluded.

**Heads of terms**

The main subject matter of a Section 106 Agreement.

**Heat island**

The accumulation of heat within a built-up area due to the absorption of solar radiation by buildings and hard surfaces and the production of waste heat by activities within the area (e.g. cars).

**Height**

The height of a building can be expressed in terms of: a maximum number of floors; a maximum height of parapet or ridge; a maximum overall height; any of these maximum heights in combination with a maximum number of floors; a ratio of building height to street or space width; height relative to particular landmarks or background buildings; and height above mean sea level or strategic views.

**Heritage asset**

A building, monument, site, place, area or landscape positively identified as having a degree of significance meriting consideration in planning decisions. Heritage assets are the valued components of the historic environment whether designated or not.

**Hierarchy**

An order or ranking of things, one above another such as towns, centres or streets. For example, Sheffield is at the top of the hierarchy of settlements in South Yorkshire while Crow Edge, Barnsley, is near the bottom. A settlement or street in a hierarchy is therefore referred to as a higher or lower order within the hierarchy.

**Historic Environment**

All aspects of the environment that are the result of people living in and changing their surroundings through time, including earthworks, fields and field boundaries, roads, engineering works, equipment, buildings, streets and settlements (all surviving physical remains of past human activity).

**Home Zone**

A street or streets designed and officially designated to be used by the local residents and community for a range of activities, as well as a place for vehicles. Features often include trees and planters, benches and play areas. Designation involves a number of specific requirements (see S2.1).

**Impermeable**

See permeability.

**Landmark**

A building, structure or other feature that stands out from its background by virtue of height, position, size or some other aspect of its design. In general, landmarks are visible from a number of different locations in an area and help in wayfinding.

**Landscape**

In general, the natural and man-made features of an area such as hills, woodland, fields roads and settlements perceived together as a whole. At the smaller scale, landscape or landscape design refers to the arrangement of outdoor spaces from networks of open space and structural planting down to local planting, surface materials, street furniture and signage.

**Legibility**

The ease with which a place can be understood and navigated with reference to its physical structure and the presence of distinct and memorable features.

**Level surface**

A type of shared space street where very low vehicle flows and speeds allow the removal of the vertical differentiation (e.g. footway with kerb) to provide a single shared surface.

**Local Distinctiveness**

The full range of things from buildings and land shapes, streams and wildlife, trees, orchards, local habits, products and language that make a place unique. A term coined by Common Ground in 1983. In their words 'local implies neighbourhood or parish. Distinctiveness is about particularity'.

**Local Highway Authority**

The local authority or council that is responsible for approving operating, maintaining and improving the local road network and associated equipment.

**Local Planning Authority**

The local authority or council that is empowered by law to exercise planning functions.

**Listed building**

A building of special architectural or historic interest. Listed buildings are graded I, II\* or II with grade I being the highest.

**Massing**

The combined effect of the height, bulk and silhouette of a building or group of buildings.

**Mews**

A specific type of street, generally a shared space or level surface street, giving access to buildings (dwellings) ancillary to at least one local or principal street. A principal role of a mews is to accommodate some or all of the parking of its associated local or principal street within the mews building or on the surface of the street (See S1.4, S2.5, B1.6).

**Microclimate**

The distinct conditions of sunlight, temperature, wind, humidity and precipitation restricted to a small area due to the influence of the disposition of orientation, topography, vegetation, buildings and boundary features.

**Mixed-use**

Combining different uses such as residential, retail and office within close proximity. There are two broad types of mixed-use: 'horizontal' where the uses are placed side-by-side, usually in different buildings; 'vertical' where the uses are found on different floors of the same building.

**Natural surveillance**

The ability of people to see and be seen by other people within the public realm as a result of the structural arrangement of streets and the orientation of buildings. Natural or passive surveillance is most commonly achieved by creating active streets with active edges where windows face out onto the street. The aim of natural surveillance is the deterrence of nuisance, anti-social behaviour and crime.

**Node**

A place where different features and activities come together, in particular paths and streets (and the people who move along them). A crossroads with a place to sit is a simple node. In general, community focal points are nodes.

**Neighbourhood**

An area of streets within an urban area in general served by a common centre.

**On-plot**

Within the property boundary, generally used with reference to parking spaces.

**Order (of street)**

Position or importance of a street within a hierarchy or ranking. Higher order streets are busy, main routes such as the primary roads leading to a main centre. Lower order streets include lanes and cul-de-sacs. In general the order of a street is based on the importance of places (or streets) it connects.

**Perimeter block**

A block with buildings arranged along the outer edge facing the surrounding streets with active edges.

**Permeability**

The extent to which an area is served by a network of connected streets that allow a choice of routes through the area. An impermeable layout has very few connections.

**Plot**

An area of land usually defined on the ground by a boundary and representing a unit of ownership. Generally, a plot contains a building or some other distinct land use (e.g. an allotment or park) and is part of a series of plots or a block with access from a street space.

**Plot series**

A row or arrangement of similar plots that forms one side (or part) of a street.

**Protected space (or zone)**

Part of a street space that is intended only for the use of pedestrians and is separated by a difference in level (usually a kerb) and colour contrast providing a continuous demarcation between the vehicle zone and the protected zone, aiding navigation for people with a visual impairment, and helping to control vehicle movements.

**Public art**

The practice and product of involving artists in the conception, development and transformation of a public space such as through the creation of artifacts, contributions to the design of street furniture or other features in the streetscape or public open space.

**Public open space**

Space within or on the edge of a settlement accessible to the public such as parks, gardens, playing fields and play areas for the purposes of formal and informal recreation or general amenity.

**Public realm**

The areas of a settlement for the general use of the public such as streets, squares and parks, most frequently in the ownership and control of a public body.

**Section 106 Agreement**

A reference to Section 106 of the Town and Country Planning Act 1990 that allows for legally binding agreements between a local authority and an applicant for planning permission by which the applicant provides works or financial contributions deemed necessary to support the proposed development, also referred to as a 'planning obligation'.

**Scale**

In general use, the impression given by a building or group of buildings when seen in relation to its surroundings, often used as a synonym for 'size.'

With specific reference to drawings, the ratio or proportion between the length or dimension of an object and the length on the drawing, e.g. 1:500.

**Section**

A drawing of a 'slice through' a site, or building cut vertically across or through it.

**Secured by Design**

A crime prevention initiative managed by ACPO CPI Limited on behalf of the UK Association of Chief Police Officers (ACPO). The initiative focuses on crime prevention at the design, layout and construction stages of development.

**Sense of place**

The unique experience that arises as a result of being in or walking through a particular locality, generally as a response to the specific characteristics and quality of a neighbourhood, street or public open space.

**Shared space**

Streets where the separation between carriageway and footway is reduced and the difference between vehicle track, where vehicles are permitted, and the area set aside for pedestrians is less physically distinct than in a conventional street.

**Solar gain**

An increase in the temperature of a room or other internal space (and its surfaces) as a result of exposure to sunlight (absorption of radiant heat from the sun).

**Speed limit**

The designated maximum speed as set by the government or local highway authority. See **Design speed**

**Strategy**

A plan of action or set of cohesive policies.

**Street**

A public (or private) highway with plots on either side that is part of a settlement or neighbourhood.

**Street furniture**

Functional objects or features within a street space such as benches, bus shelters, litter bins, equipment cabinets, lighting, railings and traffic signs.

**Street hierarchy**

The order or ranking of streets and their relative position within an area based principally on the importance of the place (or street) to which the streets connect as well as their associated levels of activity.

**Street space**

The area within the street from plot front to plot front, generally corresponding to the adopted public highway.

**Streetscape**

The overall impression given by the design, arrangement and relationship of buildings to other structures, landscaping and open space on a block or neighbourhood.

**Sustainable drainage systems (SuDS)**

Schemes for handling surface water by means other than pipes and storm drains, such as pervious surfaces, filter drains, filter strips, swales, retention or balancing ponds, infiltration basins, trenches and soakaways to reduce the potential of flooding and improve water quality on new and existing urban developments.

**Supplementary Planning Document (SPD)**

A document that provides further details and/or guidance with reference to policies and proposals contained in a Development Plan Document (DPD).

**Sustainability**

With respect to human activities, a state or process that can be maintained indefinitely, integrating three closely interlinked elements of the environment, the economy and social systems.

**Sustainable development**

Development that meets present needs without compromising the ability of future generations to achieve their own needs and aspirations.

**Tenure blind**

A design of development that does not show any differences between different housing tenures (e.g. rental or owner-occupation).

**Topography**

The three dimensional surface features of the ground, also referred to as land-form; also a description or representation of those features.

**Townscape**

The visual appearance, character and overall impression of buildings and all other features in a town or neighbourhood taken together as a whole.

**Typology**

Systematic organisation of objects such as houses or streets into similar kinds on the basis of shared attributes.

**Wayleave**

The right to use or enter property for a particular purpose. Also known as an easement. For example, electricity companies usually have a wayleave under overhead power lines for the purposes of maintenance.

**Wayfinding**

Using elements of your surroundings such as buildings and other features to orient yourself and navigate through an area.



# Ap4

## Relevant publications

Barton, H., Grant, M. and Guise, R. *Shaping Neighbourhoods* 2nd Edition

British Standards 3882 (2007) *Specification for topsoil*

British Standards 4043 (1989) *Recommendations for transplanting root-balled trees*

British Standards 4428 (1989) *Code of practice for general landscape operations*

British Standards 6375 (2009) *Performance of windows and doors*

British Standards 7950 (1997) *Specification for enhanced security performance of windows for domestic applications*

British Standards 8300 (2009) *Design of buildings and their approaches to meet the needs of disabled people. Code of practice*

British Standards EN 752 (2008) (supersedes 8005:1987) *Drain and sewer systems outside buildings*

British Standards 7000-6 (2005), *Managing inclusive design*

Elizabeth Burton, Lynne Mitchell and Shibu Raman (2004) *Neighbourhoods for Life: Designing dementia-friendly outdoor environments*

CABE Space (2005), *Start with the park*

CABE (2005) *Achieving the Building for Life standard*

CABE (September 2006) *The principles of Inclusive Design: They include you*

CABE (2008) *Evaluating housing proposals step by step*

CABE (March 2008) *Civilised Streets*

CABE (November 2008) *Inclusion by design: equality, diversity and the built environment*

Adrian Cave (August 2007) *Inclusive Accessible Design*

CIRIA (2010) *C688 Flood resilience and resistance for critical infrastructure*

Disabled Persons Transport Advisory Committee (June 2003) *Inclusive Projects*

Disabled Persons Transport Advisory Committee (March 2005) *Commitment to Inclusive Design*

DCLG (2006) *The Code for sustainable homes: Setting the standard in sustainability for new homes*

---

- DCLG, DH and DWP (2008) *Lifetime Homes and Lifetimes Neighbourhoods*
- DCLG (June 2007) *Improving the Flood Performance of New Buildings – Flood Resilient Construction*
- Department of Health (2004) *Factsheet 6: Design Principles for Extra Care*
- DETR (1998) *Places, streets and movement: a companion guide to Design Bulletin 32*
- DETR & CABE (2000) *By Design: urban design in the planning system - towards better practice*
- DTLR and CABE (2001) *Better places to live: a companion guide to PPG3*
- DfT (2002 and updates) *Inclusive Mobility*
- DfT (undated) *Guidance on the use of Tactile Paving Surfaces*
- DfT/DCLG (2007) *Manual for streets*
- English Heritage (2005) *Streets for All-Yorkshire & Humber*
- English Partnerships and the Housing Corporation (2000) *Urban Design Compendium*
- English Partnerships and Design for Homes (2006) *Car parking: what works where*
- English Partnerships and the Housing Corporation (2007) *Urban Design Compendium 2: Delivering quality places*
- Guide Dogs (January 2010) *Inclusive Streets: Design principles for blind and partially sighted people*
- HATC Ltd and Ipsos-MORI (2009) *Resident satisfaction with space in the home*
- HATC Limited (2006) *Housing Space Standards* (Greater London Authority)
- Help the Aged (undated) *Towards Common Ground: The Help the Aged manifesto for lifetime neighbourhoods*
- Littlefair, P.J. (1991) *Site layout planning for daylight and sunlight: a guide to good practice*
- ODPM and Home Office (2004) *Safer places: the planning system and crime prevention*
- Transform South Yorkshire (2008) *Design Quality Audit and Improvement Action Plans*
- Transform South Yorkshire/Sheffield City Council (undated) *Older Persons' Accommodation - Design Guide*
- Thorpe S. and Habinteg Housing Association (2006) *Wheelchair housing design guide*

## ABBREVIATIONS

<b>BfL</b>	Building for Life
<b>DETR</b>	Department for Environment, Transport and the Regions
<b>DTLR</b>	Department for Transport, Local Government and the Regions
<b>DfT</b>	Department for Transport
<b>DCLG</b>	Department for Communities and Local Government
<b>CABE</b>	Commission for Architecture and the Built Environment
<b>DH</b>	Department of Health
<b>DWP</b>	Department for Work and Pensions
<b>EA</b>	Environment Agency
<b>EH</b>	English Heritage
<b>LHA</b>	Local Highway Authority
<b>LPA</b>	Local Planning Authority
<b>MfS</b>	Manual for Streets
<b>ODPM</b>	Office of the Deputy Prime Minister
<b>SYPT</b>	South Yorkshire Public Transport Executive



# Ap5

## Key contacts and addresses

### Transform South Yorkshire

**Peter O'Brien**

Planning and Design Advisor  
25 Carbrook Hall Road  
Sheffield S9 2EJ

T 0114 2735401

F 0114 2734587

E [peter.o'brien@sheffield.gov.uk](mailto:peter.o'brien@sheffield.gov.uk)

### Barnsley Metropolitan Borough Council

**Nik King**

Senior Urban Design Officer  
Renaissance Design Conservation  
Planning and Transportation Service  
Barnsley Metropolitan Borough Council  
PO Box 604  
S70 9FE

T 01226 772628

E [nickking@barnsley.gov.uk](mailto:nickking@barnsley.gov.uk)

**Barbara Wilson**

Group Leader  
Highways Development Control & PROW  
Highways and Engineering  
Barnsley Metropolitan Borough Council  
PO Box 601  
S70 9FA

T 01226 772177.

E [barbarawilson@barnsley.gov.uk](mailto:barbarawilson@barnsley.gov.uk)

**Doncaster Metropolitan Borough Council****Jordan Butler**

Senior Planner (Urban Renaissance)

T 01302 734892

F 01302 734949

Development and Planning  
Doncaster Metropolitan Borough Council,  
2nd Floor Danum House  
St Sepulchre Gate  
Doncaster DN1 1UB

T 01302 731234

F 01302 731234

E [jordan.butler@doncaster.gov.uk](mailto:jordan.butler@doncaster.gov.uk)

**Graham Hargraves**

Highways Development Control Group Leader

2nd Floor, Danum House

St Sepulchre Gate

Doncaster DN1 1UB

T 01302 735115

F 01302 734949

E [graham.hargraves@doncaster.gov.uk](mailto:graham.hargraves@doncaster.gov.uk)

**Rotherham Metropolitan Borough Council****Noel Bell**

Environment and Development Services

Rotherham Metropolitan Borough Council

Bailey House

Rawmarsh Road

Rotherham S60 1TD

T 01709 254742

F 01709 823865

E [noel.bell@rotherham.gov.uk](mailto:noel.bell@rotherham.gov.uk)

**Sheffield City Council****Andy Van Vliet**

Planning Division  
4th Floor Howden House  
1 Union Street  
Sheffield S1 2SH

T 01142 734992

E [Andy.Vanvliet@sheffield.gov.uk](mailto:Andy.Vanvliet@sheffield.gov.uk)

**Ian Wheeldon**

Highways and Transport  
4th Floor Howden House  
1 Union Street  
Sheffield S1 2SH

T 01142 736368

E [Ian.wheeldon@sheffield.gov.uk](mailto:Ian.wheeldon@sheffield.gov.uk)



# Index

- A**
- Active frontage .....29, 44, **89**, 108,110, **121**, 124
  - Accessibility ..... 17, 19, **41-3**, 47, **58**, 78,  
..... 108-9, 131-2, 200
  - Adaptability ..... **32**, **101**, 110, 130, 201-2
  - Affordable housing ..... 14, 18, 47
  - Amenity space ..... 49, 80, 112-3, **122**, **129**
  - Appraisal ..... 13, 14, 17-33, **38-53**
- B**
- Backs (fronts and) ..... 21, 24-29, 52, **89**
  - Biodiversity ..... 14, **50**, **73-4**, 103, 170
  - Block ..... 48, 65,  
interior ..... **112-13**  
perimeter block ..... **110-11**  
shape and size ..... **114**
  - Building .....13, 14, 22, 31, 32, 33, **118-25**  
depth ..... 112, 119, 124  
form ..... **123-24**  
height ..... 15, 25, 69-70, 86, 92, **94**, 131  
layout ..... 25, 26,  
line ..... 25, 90, 92,134, **108**  
roof ..... 119, **124**  
type ..... 12, 13, 14, 18, 80, 108,  
..... **110-13**, 115-6, **118-20**
  - Building for Life ..... 4, **7-9**, **16-33**, **39**
- C**
- Car parking ..... (see parking)
  - Carbon .....20, 49, 67-8,120, 201-2
  - Centres ..... 17, 28, 47, **56-7**, 58, 59,  
..... **81**, 92-3, 199-200
  - Character ... 14, **21-5**, 59, **62-4**, 74, 83-6, 88, **92**, 201  
appraisal ..... **48**, 50, 51, 52  
areas ..... **65**, 66
  - Code for Sustainable Homes .....5, 14, 20, 33, 39, 67  
..... 112, 120, 131, 194
  - Community .....12-14, 17, 18, 39-44, 47, 57  
focal point ..... 24, 47, 51, **60**, 70, 74,  
..... **76**, 77, 81, 83, **101**,103
  - Connections .....24, 28, 29, 38, 44, 50, 51,  
..... 61, 73, 76, 77, **81-2**, 114
  - Conservation area ..... 65, 66, 108
  - Construction waste ..... 194
  - Continuous access ..... 27, **99**, 106
  - Corner .....31, 89, 110-11, 112, 117, **119**
  - Cycle/cycling ..... 14-15, 17, 27, 28, 42,  
..... 58, 75, 77, **79**, 90  
parking/storage .....27, 102, 131, **135**, 136  
route/track ..... **139**, 140, **142**, **143**, **146**, **186**, **189**  
security/lighting ..... 165
- D**
- Daylighting ..... 68, 94, 112, 120, 123, 129
  - Density ..... 12, 13, 14, **59**, 80, 97, 110-14, **115**
  - Disabled access ..... (see Inclusive design)
  - Distinctiveness ..... (see Local distinctiveness)
  - Drainage ..... 20, 50, 52, 53  
highway ..... **158-60**  
SuDS/surface water ..... 66, **71-2**, 73, 74, 90, 103  
technical requirements ..... **155-61**  
trees ..... **173**
- E**
- Edge ..... 52, 73, 74, 83
  - Enclosure ..... 25, 52, 83, 86, **94**, 95,
  - Energy .....31, 49, 67, 71, 120  
renewable ..... 20, **67**, **68**, **69**
- F**
- Façade .....52, 96, 121, 124, 125
  - Flexibility .....4, 30, 38, 41, 81-2, **101**, 114
  - Focal points .....52, 57, 70, **83**, 92, 97, 201  
community ..... 24, 47, 51, **60**, 70, 74,  
..... **76**, 77, 81, 83, **101**,103
  - Footpath ..... 22, 51, 52, 75, 140, 141, 159, 165, 189
  - Footway ..... 27, 42 , 78, 90, 92, 96, 97-8, 101,  
..... 133-35, 137, 140, 141, 144, 145, **146**

- Fronts/frontage ..... 25, 28, 29, 44, 52, 72, 88, 90,  
..... 92, 95, 96, **108**, 110-11, 116-17, 121, 125  
active.....29, 44, **89**, 108,110, **121**, 124  
and backs ..... 21, 24-9, 52, **89**
- G**
- Garden..... 15, 25, 26, 29, 80, 95, 108,  
..... **111-14**, 121, **122**, **129**
- Gateway..... 24, 31, **83**, 103, 133
- Green infrastructure ..... 22, 30, 50, 60, 61,  
..... 70, 71, **73**, 92, 199
- H**
- Habitat .....20, 22, 30, 50, 61, 69,  
..... 70, **73**, **74**, 103, 156
- Heritage asset..... 14, 22, 52, **66**, **83**
- Hierarchy ..... 76, 118, 119, 121, 123  
place ..... 56, **76**, 83  
order (higher/lower) ..... 51, 76, 81, 93, 94, 97,110  
route/street.....24-9, 51, 75, **76**, 83, 86, 91-3
- Highways ..... 26, 29, 38, 75  
adoption.....**189-93**  
design parameters and geometry.....**133-54**  
structures .....**162-64**
- I**
- Inclusive design ..... 5, 15, 27, **39-44**, 51, 57-8,  
..... 75, 77, 99, 118, 131-32, 146, 200
- Integration..... 4, 22, 26, 28, 38, 44-5, 199  
neighbourhoods..... 57, 75  
streets ..... **96**
- J**
- Junction ..... 60, 78, 81, 92, 100, 110, **147-52**
- L**
- Landmark..... 24, 52, 60, 76, 83, 84, 85, 104
- Landscape ..... 13, 15, 21, 22, 50, 61, 84  
character ..... 48, 62-4, 65, 69, 125  
features ..... 66, 73, **74**, 92  
framework/structure ..... 73, **74**, 83, 86, 97, 105
- Legibility ..... 52, 74, **83-6**, 92-4, 108, 110
- Level surface (street)..... **91**, 97, **98**, 133-34, 167
- Lifetime homes..... 5, 15, 26, 32, 39, 43, 116, 117,  
..... **118**, 120, **130-2**, 135-36
- Listed building ..... (see Heritage Asset)
- Local distinctiveness..... 4, 14, 23, 38, 62-4, 65, 66,  
..... 75, 76, 84, 92, 106, 109, 125, 201
- Local resources ..... 20, 49, **67-9**
- M**
- Maintenance ..... 30, 61, 70, 71, 74, **91**, 103, 104,  
..... 135, 145, 147, 155, 156-57, 162, 163,  
..... 166, 175-6, 184, 189, 192-93, 195, 200
- Management ..... 30, 50, 73, **91**, 103, 122, 129,  
..... 170, 176, 184, 192, **195**
- Materials ..... 13, 15, 30, 48, 62-4, 65, 86, 90, 92,  
..... 97, 99, **106**, 124, **125**, **184-86**
- Meter boxes ..... **125**
- Microclimate .....20, 49, 68, **70**, 88, 97, 103
- Movement ..... 12, 13, 15, 41, 88, 89, 99  
and other uses ..... 60, 61, 74, 129  
analysis/appraisal..... 48, **51**, 52, 57, 81  
structure/framework ..... **75-79**, 81-2, 93
- N**
- Neighbourhood..... 1, 5, 12, 17, 18, 21, 38, 41-2, 47,  
..... 51, 52, **56-7**, **59**, 74, 75, 77, 81, 88-9, 101
- O**
- Open space .....12, 13, 14, 17, 50, 56-7, **60-1**, 85  
design ..... 101, 103, 104, 121, 129, 156  
management ..... 195  
networks..... **61**, **73**, **74**, 76, **86**, 94, **97**, 199  
private/shared provision..... 112, 129
- P**
- Parking..... 4, 13, 15, 26-7, 41, 43, 57-8, **80**, 85, 109  
cycle.....27, 58, 78, **79**, **80**, 90, 131  
mews.....**91**, **102**  
off-street ..... 90, 112-15, **116-17**, 134, **135-7**  
on-street .....78, 101, **102**, 103, 108,  
..... 133-4, **142-5**, **185**, **189**  
strategy .....26-7, **80**, 114, 116, 195
- Perimeter block..... 86, **110**, 112 -13
- Place..... 4, 23, 52, 60, 62, 66, **76**,  
..... 83-4, 86, 88, **89**,92
- Planning policy ..... 5, 15, 39, 43, 58,  
..... 105, 115, 118, 131
- Planting.....15, 21-3, 70, **73-4**, 85, 86, 94-5, 97,  
..... **103-6**, 108, 142, 145-7, 151, 153,  
..... 156-7, 168, **17-184**, 189, 191-3, 195
- Plot .....32, 48, 52, 65, 80, **88**, 89, 90, **94-6**,  
..... 114, 116-7, **118**, 119-21, 123, 132  
series ..... **108-11**
- Public art..... 86, **104-5**, 153
- Public open space .....(see Open space)
- Public realm ..... 13, 15, 30, **41-2**, 60-1, 66, 72, 74  
..... 83, **86**, 88, **95**, **97-106**, **121**, **184-88**
- Public transport..... 13, 15, 19, 28, 51, 57-8, 75,  
..... 77, **78**, 81-2, 101, 115, 142
- R**
- Recreation..... 47, 56, 57, **61**, 73
- Recycling ..... 49, **72**, 113, 125, 131, 171, 201
- Renewable energy ..... 20, 49, **67-9**, 120, 201

- Resources.....(see Local resources)
- Roof form.....22, 71, 84-5, 108-9, 123, **124**, 155 -7
- Route .....24-9, 51, 75, **76**, 83, 86, 91-3  
 hierarchy .....76, 118, 119, 121, 123  
 order (higher/lower) .....51, 76, 81, 93, 94, 97,110  
 structure..... 51, 66, 110  
 type.....51, **91**, **97-8**, **133-35**
- S**
- Safety and security ..... 14, **42-4**, 58, 70, 75, 81-2,  
 ..... 100, 104, 110-11, 113, 132, 137,  
 ..... 142, 165, 170, 174, 184, 200
- Set-back..... 90, 94-5, **108**
- Services (and facilities) ..... 19, 41-3, 47, 51, **56-8**,  
 ..... 75, 81, 115
- Services (utilities).. 67, **106**, 125, 153, 156-7, **167-69**
- Shared surface..... (see Level Surface)
- Shared space..... **91**, **97-8**, **133-35**, 146, 150, 167
- Signage.....30, 60, 77, 99, 100, **104-05**, 137, **187-88**
- Slope ..... 47, 53, 68, **84**, 85, 89, **109**, 123, 137
- Solar energy ..... 20, 49, 67, **68**, 89, 114, 120, 123,
- Space standards..... 15, 32, 114-15, **123**, **129-32**
- Spatial enclosure ..... 52, **94**, 110
- Speed ..... 15, 27, 58, 77, 82, 97-8, **100-01**,  
 design speed .....98, **100**, **133-4**, **137-9**  
 limit .....**137**
- reduction..... 82, 90, 93, **100-02**, **152-54**
- Storage ..... **123**, **130-2**  
 cycle..... 79, 113, **123**  
 waste..... 72, 85, 113, **123**, **125**
- Surface materials ..... 30, 90, 97, **106**, 136, **184-86**
- Surface water drainage ..... (see Drainage)
- Sustainable urban drainage ..... (see Drainage)
- Sustainability..... 4, 14, 20, 38, 39, 41,49, 59, 101  
 appraisal/statement..... 14, 20, **49**, **67**, **71**
- Street ..... 13-5, 25-30, 42, 51, 52  
 connections.....24, 28-9, 38, 44, 51, **76**, 77,  
 ..... **81-2**, 86, 91, 110, 114  
 furniture..... 15, 30, 42, 61, 90, 97,  
 ..... 100, **104-5**, 187-88  
 geometry ..... 52, 84-5, 96, 100, **133-54**  
 hierarchy .....**76**, 118, 119, 121, 123  
 lighting ..... 15, 29, 30, 60, 61, 86, 90,  
 ..... **103-05**, 134,**165-66**  
 materials ..... 13, 15, 30, 48, 86, 90,  
 ..... 97, **106**, 184-86  
 order (higher/lower) .....51, 76, 81, 93, 94, 97,110  
 parking.....78, 101, **102**, 103, 108,  
 ..... 133-4, **142-5**, **185**, **189**  
 pattern/network ..... 13, 15, 19, 51, 65, **75-7**,  
 ..... **81-2**, 86, 114  
 space ..... 44, 60, 76, 88, 89, 90, 91, 94, 96  
 ..... **97-8**, 100, 101, 102, 104-5  
 trees ..... 15, 74, 86, 90, 94, 102, **103-04**,**170-83**  
 type.....51, **91**, **97-8**, **133-35**
- T**
- Topography.....21-3, 49, 51, 52, 62, 71, 74, 77,  
 ..... **83-5**, 88, 92-3, 109, 114, 123, 137, 210
- Townscape.....21, 48, 52, 74, **83-86**, 97, 110, 199
- Tracking ..... 15, 78, 145, 150,
- Traffic calming.....82, 90, 93, **100-02**, **152-54**
- U**
- Users .....27, **39-40**, 44
- Utilities ..... 67, **106**, 125, 153, 156-7, **167-69**
- V**
- Views .....21-2, 24, 52, 66, **83-6**, 92, 94, 104, 108-9
- W**
- Walking ..... 17, 58, 75, **77**, **81-2**, 84, 114-5
- Waste ..... 49, 67, **72**, 113, 125, 131, 142, 152, 194
- Wheelchair housing ..... 15, 18, 26, 32, 43,  
 ..... 117-18, 131-32
- Wildlife ..... 39, 73-4, 156
- Wind ..... 49, 50, 67, **69**, 70, 89, 114, 12000

## Acknowledgement

### Project team

#### studio | REAL

Karl Kropf, Annemarie De Boom, Rachel Aldred, Fern Lee, Nick Beedie, Dominic Busby

#### Phil Jones Associates

Phil Jones

#### Steering Group

Peter O'Brien (Transform South Yorkshire)

Nik King and Barbara Wilson (Barnsley)

Jordan Butler and Graham Hargraves (Doncaster)

John Royston, Phil Turnidge and Noel Bell (Rotherham)

Andy Van Vliet and Ian Wheeldon (Sheffield)



